

 深圳市福瑞达显示技术有限公司 SHENZHEN FRIDA LCD CO.,LTD	Doc.No.: FRD2400L51001-A-GBQ	
	REV: A	PAGE: 1/47
SPEC TITLE DOCUMENT CONTROL SPECIFICATION	EFFECTIVE DATE: 2025-03-27	

PRODUCT SPECIFICATION

TFT-LCD MODULE

Model No: FRD2400L51001-A-GBQ

For Customer's Acceptance	
Approved by	Comment

	Signature	Date
Prepared by		2025.03.27
Checked by		2025.03.27
Approved by		2025.03.27

深圳市福瑞达显示技术有限公司

工厂地址: 深圳市光明新区公明田寮第二工业区田荣路 68 号

Manufacturing base:

The 68th, Tianrong Road, Tianliao Community, Gongming town, Guangming District, Shenzhen,China.

总部地址:深圳市光明区光明大道云创谷园区 2 栋 18 楼

Headquarters: 18th Floor, 2nd Building, Yunchuang Valley Park, Guangming Avenue, Guangming District, Shenzhen,China.

电话(Tel):0755-23422110

网址(Web):www.fridalcd.com

sales@fridalcd.com



SPEC TITLE

DOCUMENT CONTROL SPECIFICATION

EFFECTIVE DATE: 2025-03-27

Table of Contents

Record of Revision

- 1 General Specifications
- 2 Touch Design
 - 2.1 General Specifications
 - 2.2 Electrical Characteristics
 - 2.3 Touch Panel Design
 - 2.4 Touch Part Schematic
 - 2.5 TSP Electronic Part List
 - 2.6 Touch & Panel Pin Assignment
 - 2.7 Panel Part Schematic
- 3 Input/output Terminals
 - 3.1 MCU and MIPI and SPI Module Interface Conflagration
- 4 Absolute Maximum Ratings
 - 4.1 Driving AMOLED Panel
 - 4.2 Driving AMOLED Panel
- 5 AC Characteristics
 - 5.1 MIPI Interface Characteristics
 - 5.2 MCU Interface Characteristics
 - 5.3 QSPI Interface Characteristics
 - 5.4 Display RESET Timing Characteristics
- 6 Recommended Operating Sequence
 - 6.1 Display Power on Sequence
 - 6.2 Display Power off Sequence
- 7 Optical Characteristics Optical Specification
- 8 Environmental /Reliability Test
- 9 Quality Level
 - 9.1 Definition and description
 - 9.2 Execution level
 - 9.3 content
 - 9.4 Inspection tools
 - 9.5 Judgment description
 - 9.6 Inspection standard
 - 9.7 Telecommunication inspection standard
 - 9.7.1 Appearance inspection standard
 - 9.7.3 Inspection picture library
- 10 Mechanical Drawing
- 11 Precautions for Use of AMOLED Modules
 - 11.1 Handling Precautions
 - 11.2 Storage Precautions
 - 11.3 Transportation Precautions



1 General Specifications

Feature		Spec	Remark
Display Spec	Screen Size (inch)	2.4	
	Display Mode	AMOLED	
	Display method	Active Matrix TFT	
	Resolution(dot)	450(W)x600(H)	
	Active Area(mm)	36.72 (H) x 48.96 (V)	
	PPI	311	
	Pixel Configuration	V-style3	
	Technology Type	LTPS	
	With TP/Without TP	With TP (with TP-FPC)	
	Panel Outline Dimension(W x H x D) (mm)	43.12*59.80*1.61	
Electronic	Driver IC (Type)	ICNA3312	
	Touch IC (Type)	GTW623	
	Frame Rate	60Hz	

Note 1: Requirements on Environmental Protection: RoHS 2.0



2 Touch Design

2.1 General Specifications

NO	ITEM	SPEC	REMARK
1	Accuracy @D7mm Finger(mm)	center area: $\leq 1.0\text{mm}$ edge area: $\leq 1.5\text{mm}$	
2	Linearity @ D7mm Finger(mm)	center area: $\leq 1.0\text{mm}$ edge area: $\leq 1.5\text{mm}$	
3	Jitter @D9mm Finger(mm)	center area: $\leq 0.4\text{mm}$ edge area: $\leq 0.5\text{mm}$	
4	Distance between two fingers	$\leq 13\text{mm}$	
5	Touch Point	10	

2.2 Electrical Characteristics

2.2.1 Maximum Ratings

Item	Symbol	MIN	MAX	Unit
TP power supply Input	TSP_AVDD	-0.5	4.0	V

2.2.2 Power supply DC characteristics

Item	Symbol	MIN	TYP	MAX	Unit
TP power supply Input	TSP_AVDD	2.7	2.8/3.0/3.3	3.6	V

2.3 Touch Panel Design

Item	Description	Notes
Touch Design	Sensor structure	On cell
	Sensor pitch	Tx:4.595mm , Rx:4.9mm
	Sensor pattern	Diamond
	CH Number	8 (Tx) / 10 (Rx)
	Trace mode	1T1R

2.4 Touch Part Schematic

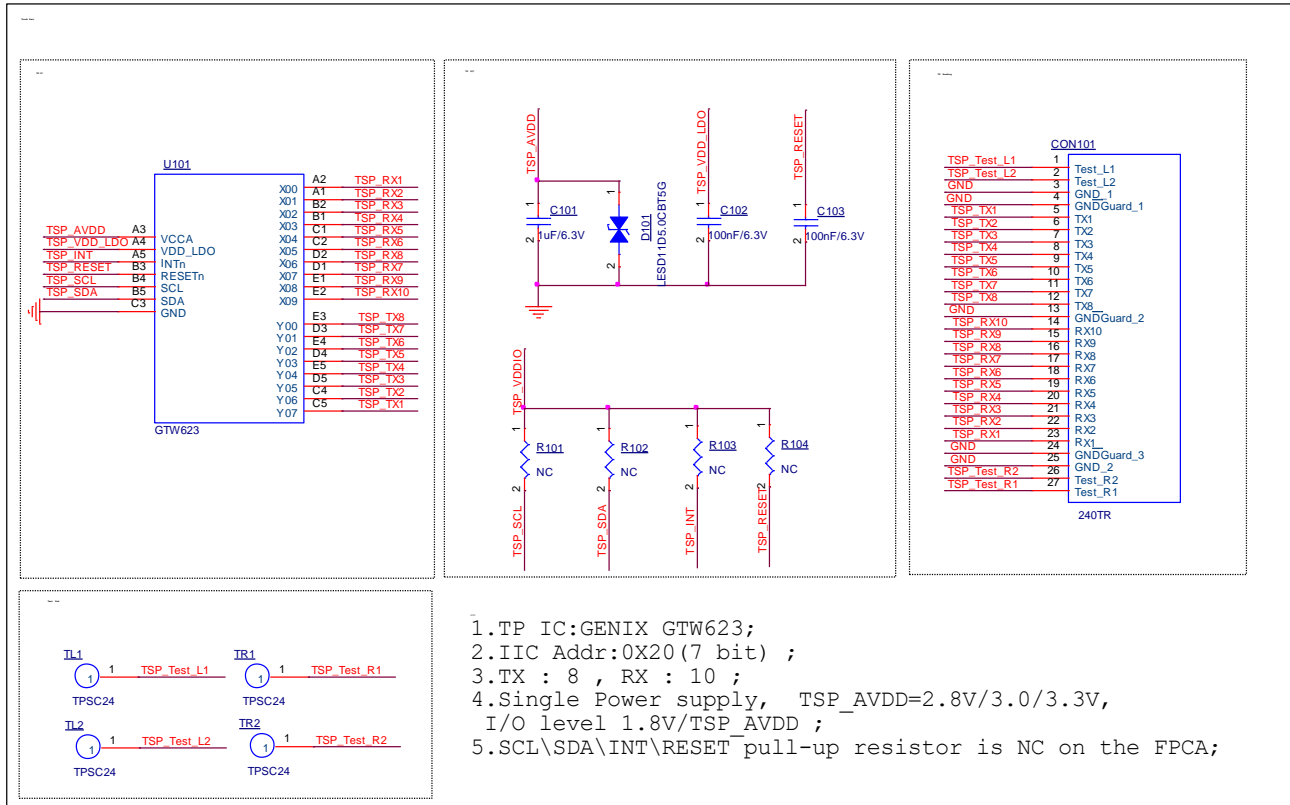

2.5 TSP Electronic Part List

Item	Reference	Specification
1	C101	1.0uF,6.3V,0201
2	C102 C103	100nF,6.3V,0201
3	D101	5V,0201
4	U101	Touch IC ,GTW623

2.6 Touch & Panel Pin Assignment

Pin Number	Pin Name	I/O	Function
1	GND	Power	Ground
2	ELVSS	Power	Negative Power supply for Panel
3	ELVSS	Power	Negative Power supply for Panel
4	GND	Power	Ground
5	ELVDD	Power	Positive Power supply for Panel
6	ELVDD	Power	Positive Power supply for Panel
7	GND	Power	Ground
8	VCI	Power	Power supply for display driver IC analog system.



9	VDDIO	Power	Power supply for display driver IC interface and logic system															
10	GND	Power	Ground															
11	TE1	O	IC Status active reporting pin.															
12	SWIRE	O	Swire protocol setting pin of Power IC															
13	TE	O	Tearing effect output pin to synchronize MCU to frame writing, activated by S/W command. When this pin is not activated, this pin is output low.															
14	GND	Power	Ground															
15	RESX	I	Display driver reset, must be applied to properly initialize the chip. Signal is active low.															
16	GND	Power	Ground															
17	SDO																	
18	SDI_RDX	I/O	SDI: Serial input signal in SPI I/F. The data is input on the rising edge of the SCL signal. RDX: Reads strobe signal to write data when RDX is "Low" in 80-series MPU interface.															
19	DCX	I	Display data / command selection in 80-series MPU I/F and 4-wire SPI I/F.															
20	SCL	I	WRX : Writes strobe signal to write data when WRX is "Low" in 80-series MPU I/F. SCL: A synchronous clock signal in SPI I/F.															
21	CSX	I	Chip select input pin ("Low" enable) in 80-series MPU I/F and SPI I/F.															
22	GND	Power	Ground															
23	D0	I/O	8-bit bi-directional data bus for 80-series MPU I/F and 8-bit input data bus for RGB I/F.															
24	D1	I/O																
25	D2	I/O																
26	D3	I/O																
27	D4	I/O																
28	D5	I/O																
29	D6	I/O																
30	D7	I/O																
31	GND	Power	Ground															
32	IM1	I	<table border="1"> <thead> <tr> <th>IM[1:0]</th> <th>Display Data</th> <th>Command</th> </tr> </thead> <tbody> <tr> <td>00</td> <td>MIPI / 3-wire SPI</td> <td>MIPI / 3-wire SPI</td> </tr> <tr> <td>01</td> <td>MIPI / 4-wire SPI</td> <td>MIPI / 4-wire SPI</td> </tr> <tr> <td>10</td> <td>MIPI / QUAD-SPI</td> <td>MIPI / QUAD-SPI</td> </tr> <tr> <td>11</td> <td>MCU 8-bit</td> <td>MCU 8-bit</td> </tr> </tbody> </table>	IM[1:0]	Display Data	Command	00	MIPI / 3-wire SPI	MIPI / 3-wire SPI	01	MIPI / 4-wire SPI	MIPI / 4-wire SPI	10	MIPI / QUAD-SPI	MIPI / QUAD-SPI	11	MCU 8-bit	MCU 8-bit
IM[1:0]	Display Data	Command																
00	MIPI / 3-wire SPI	MIPI / 3-wire SPI																
01	MIPI / 4-wire SPI	MIPI / 4-wire SPI																
10	MIPI / QUAD-SPI	MIPI / QUAD-SPI																
11	MCU 8-bit	MCU 8-bit																



SPEC TITLE

DOCUMENT CONTROL SPECIFICATION

EFFECTIVE DATE: 2025-03-27

33	IM0	I	
34	GND	Power	Ground
35	DSI_CLKP	I/O	Differential data signals if MIPI interface
36	DSI_CLKN	I/O	Differential data signals if MIPI interface
37	GND	Power	Ground
38	DSI_D0P	I/O	Differential data signals if MIPI interface
39	DSI_D0N	I/O	Differential data signals if MIPI interface
40	GND	Power	Ground
41	MTP_PWR	Power	MTP programming power supply. Must be left open or connected to GND in normal condition
42	GND	Power	Ground
43	GND	Power	Ground
44	TSP_SDA	I/O	TP I2C Data
45	TSP_SCL	I/O	TP I2C CLK
46	TSP_INT	I/O	TP INT
47	TSP_RESET	I/O	TP INT
48	GND	Power	Ground
49	TSP_VDDIO	Power	1.8V power for TP
50	TSP_AVDD	Power	2.8V power for TP
51	GND	Power	Ground

2.7 Panel Part Schematic

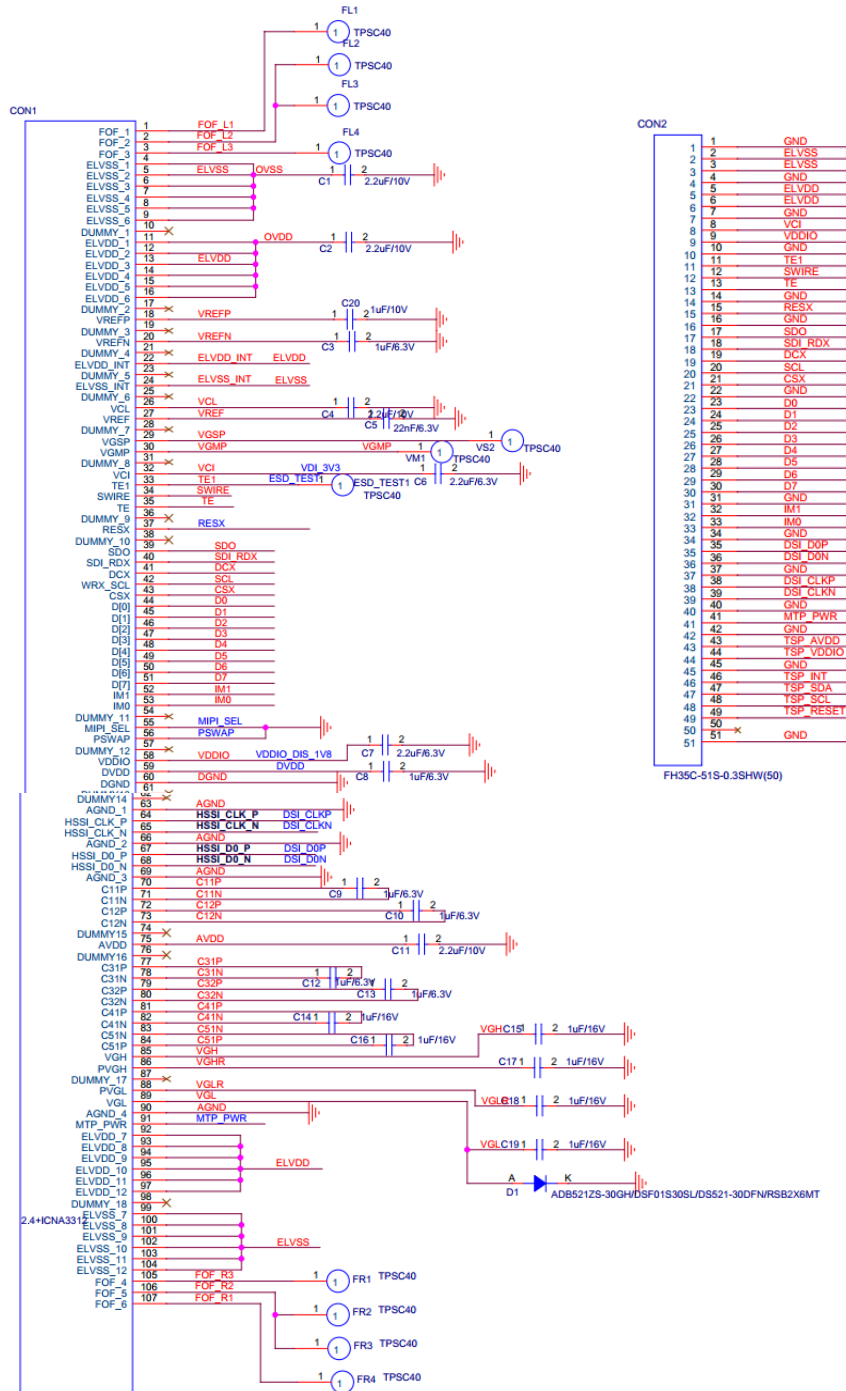

3 Input/output Terminals

3.1 MCU and MIPI and SPI Module Interface Conflagration

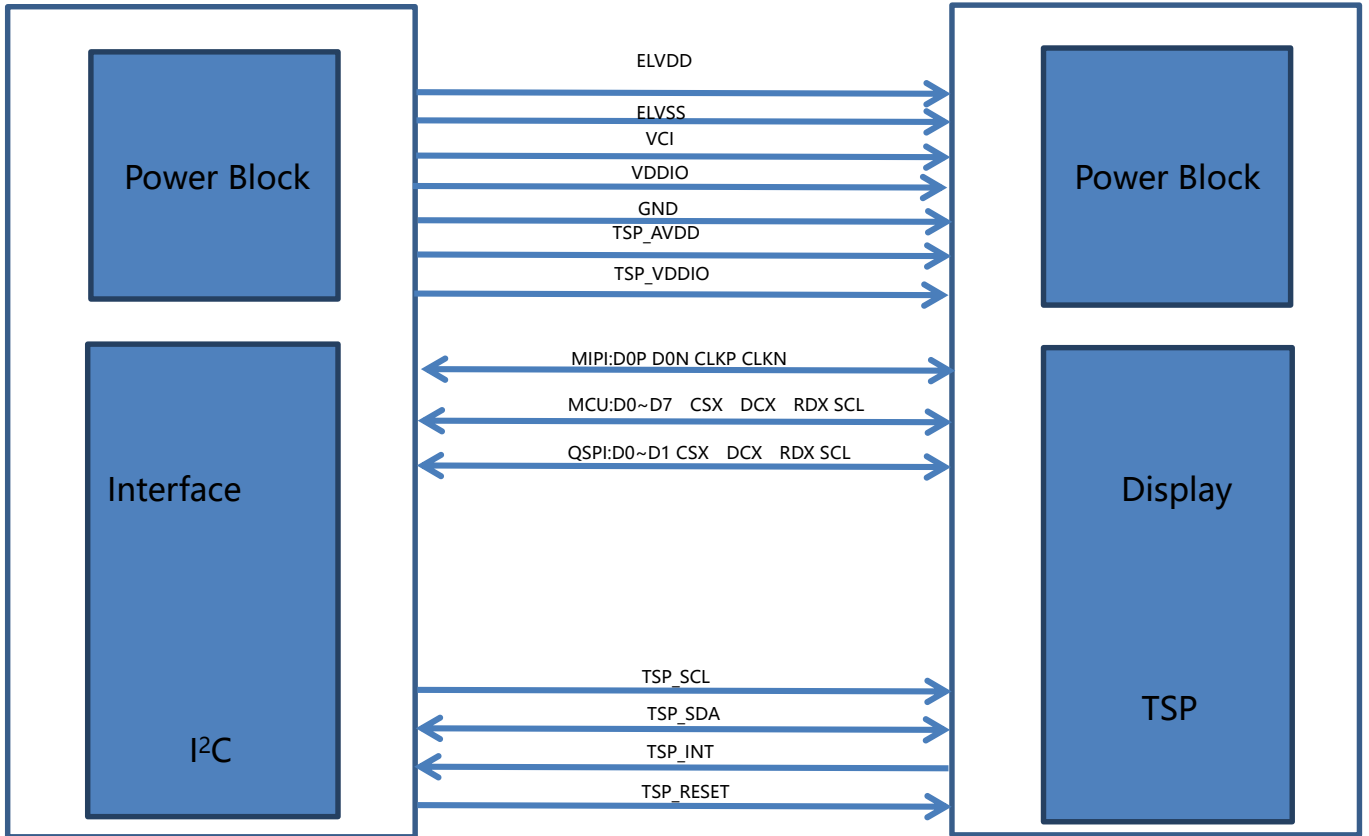



SPEC TITLE

DOCUMENT CONTROL SPECIFICATION

EFFECTIVE DATE: 2025-03-27

4 Absolute Maximum Ratings

4.1 Driving AMOLED Panel

Maximum Ratings (Voltage Referenced to VSS) VSS=0V, Ta=25°C

Item	Symbol	MIN	MAX	Unit
Analog Power supply	VCI	0	+5.5	V
Logic Power supply	VDDIO	0	+5.5	V
Positive Power Input	ELVDD	-	+5.0	V
Negative Power Input	ELVSS	-5.0	-	V

4.2 Driving AMOLED Panel

Item	Symbol	MIN	TYP	MAX	Unit	
Logic Power Supply	VDDIO	1.65	1.80	3.3	V	
Analog Power Supply	VCI	2.5	3.30	3.60	V	
Analog Power Supply	AVDD	3.9	-	6.0	V	
Default Positive Output Voltage	ELVDD		3.50		V	
Positive Output Voltage Total Variation			-		%	
Default Negative Output Voltage	ELVSS		-3.50		V	
Negative Output Voltage Total Variation			-		%	
Input Signal Voltage	High Level	VIH	0.70*VDDIO	-	VDDIO	V
	Low Level	VIL	0.00	-	0.30*VDDIO	V
Output Signal Voltage	High Level	VOH	0.80*VDDIO	-	VDDIO	V
	Low Level	VOL	0.00	-	0.20*VDDIO	V

- Note 1:** Including of all logic I/O pins.
- Note 2:** Including of TE, TE1, SWIRE.
- Note 3:** Oscillator = 24MHz

5 AC Characteristics

5.1 MIPI Interface Characteristics HS Data Transmission Burst

High Speed Mode - Clock Timings

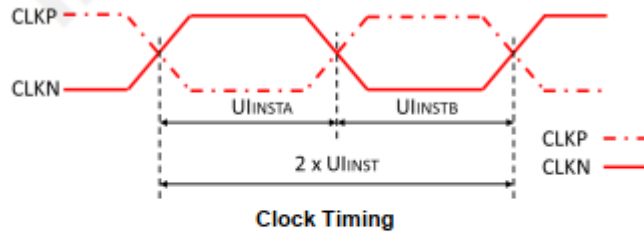

High Speed Mode - Clock Timing

Signal	Symbol	Parameter	Specification			Unit	Notes
			MIN	TYP	MAX		
CLK P/N	$2xUI_{INST}$	Double UI instantaneous	4		25	nS	
CLK P/N	UI_{INSTA}, UI_{INSTB}	UI instantaneous Half	2		12.5	nS	1

High Speed Mode - Clock / Data Timings

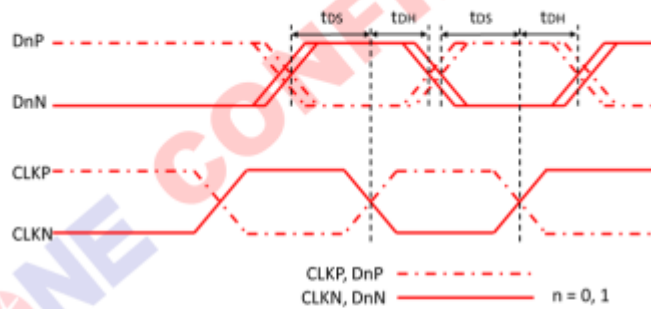

DSI Clock / Data Timings

High Speed Mode - Clock / Data Timing

Signal	Symbol	Parameter	Specification			Unit	Notes
			MIN	TYP	MAX		
Dn P/N (n=0, and 1)	tDS	Data to Clock Setup time	$0.15 \cdot UI$			UI	
	tDH	Clock to Data Hold time	$0.15 \cdot UI$			UI	

SPEC TITLE

DOCUMENT CONTROL SPECIFICATION

EFFECTIVE DATE: 2025-03-27

High Speed Mode - Rising and Falling Timings

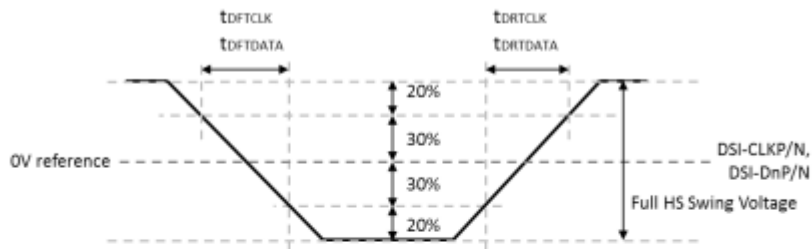

Figure 6-2 Rising and Falling Timings

High Speed Mode - Rising and Falling Timing

Parameter	Symbol	Conditions	Specification			Unit	Notes
			MIN	TYP	MAX		
Differential Rise Time for Clock	tDRTCLK	CLKP/N	150pS		0.3*UI		2,3
Differential Rise Time for Data	tDRTDATA	DnP/N	150pS		0.3*UI		1,2,3
Differential Fall Time for Clock	tDFTCLK	CLKP/N	150pS		0.3*UI		2,3
Differential Fall Time for Data	tDFTDATA	DnP/N	150pS		0.3*UI		1,2,3

Note 1: DnP/N, n =0, and 1.

Note 2: The display module has to meet timing requirements, which are defined for the transmitter (MCU) on MIPI D-PHY standard.

Note 3: DSI-CLK+ = CLKP.

DSI-CLK- = CLKN.

DSI-D0+ = D0P.

DSI-D0- = D0N.

Low Speed Mode - Bus Turn Around

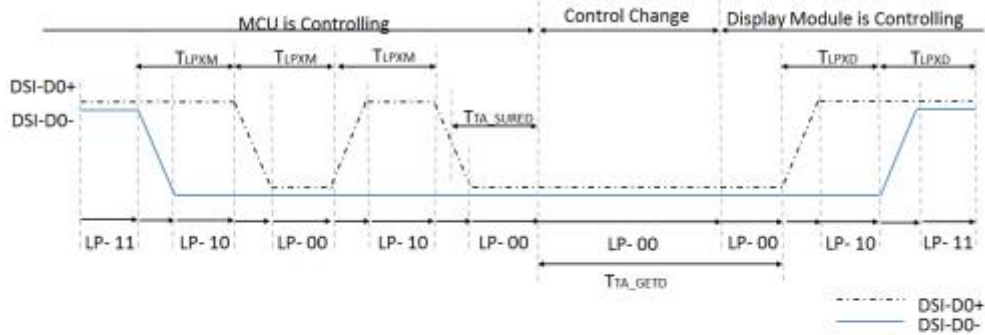

Bus Turnaround (BTA) from MCU to display module Timing

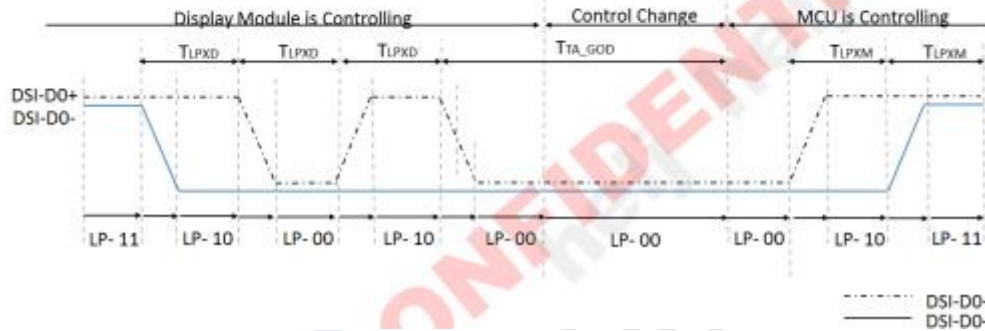

Low Speed Mode - Bus Turn Around Timing

Signal	Symbol	Parameter	Specification			Unit	Notes
			MIN	TYP	MAX		
D0P/N	TLPXM	Length of LP-00,LP-01,LP-10 or LP11 periods MCU to Display Module	50		75	nS	1
D0P/N	TLPXD	Length of LP-00,LP-01,LP-10 or LP11 periods Display Module to MCU	50		75	nS	1
D0P/N	TTA_SURED	Time-out before the Display Module starts driving	TLPXD		2 * TLPXD	nS	1
D0P/N	TTA_GETD	Time to drive LP-00 by Display Module	5 * TLPXD			nS	1
D0P/N	TTA_GOD	Time to drive LP-00 after turnaround request -MCU	4 * TLPXD			nS	1

Note 1: D0P = DSI-D0+, D0N = DSI-D0-

Data Lanes from Low Power Mode to High Speed Mode

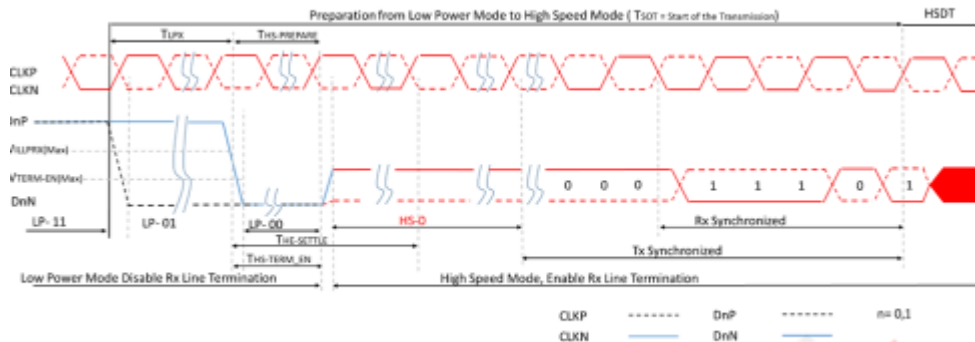

Data Lanes from High Speed Mode to Low Power Mode Timing

Data Lanes from Low Power Mode to High Speed Mode Timing

Signal	Symbol	Parameter	Specification			Unit	Notes
			MIN	TYP	MAX		
DnP/N	TLFX	Length of any Low Power State Period	50			nS	1
DnP/N	THS-PREPARE	Time to drive LP-00 to prepare for HS Transmission	40+4*UI		85+6*UI	nS	1
DnP/N	THS-TREN-EN	Time to enable Data lane Receiver line termination measured from when Dn crosses VILMAX			35+4*UI	nS	1

Note 1: DnP/N, n=0, and 1

Data Lanes from High Speed Mode to Low Power Mode

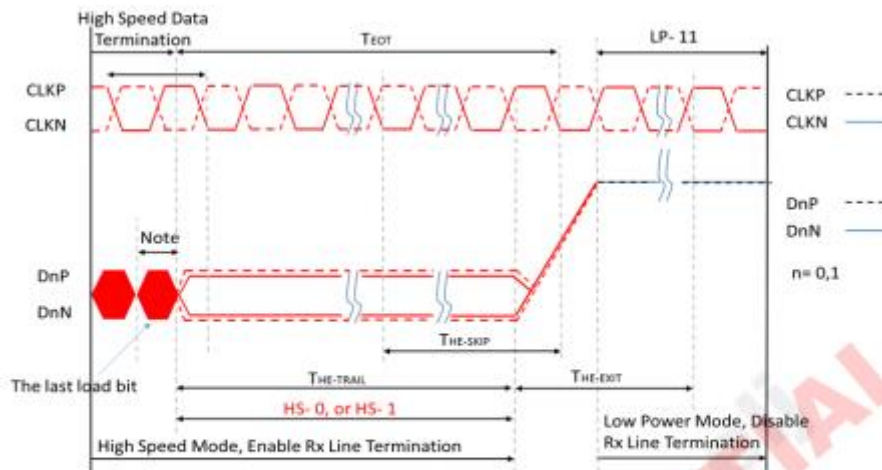

Note:
If the last load bit is HS- 0, the transmitter changes from HS- 0 to HS- 1.
If the last load bit is HS- 1, the transmitter changes from HS- 1 to HS- 0

Data Lanes from High Speed Mode to Low Power Mode Timing

Data Lanes from High Speed Mode to Low Power Mode Timing

Signal	Symbol	Parameter	Specification			Unit	Notes
			MIN	TYP	MAX		
DnP/N	THS-SKIP	Time-Out at Display Module to ignore transition period of EoT	40		55+4*UI	nS	1
DnP/N	THS-EXIT	Time to drive LP-11 after HS burst	100			nS	1

Note 1: DnP/N, n=0, and 1.

DSI Clock Burst – High speed mode to /from Low Power Mode

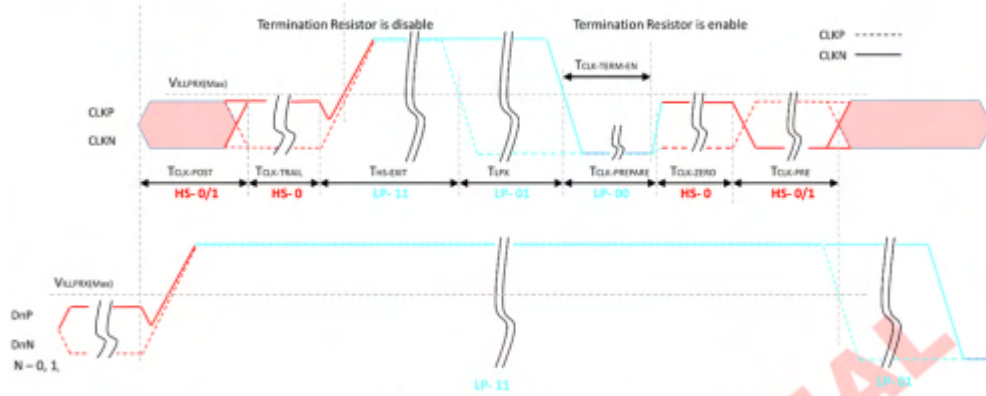

Clock Lane –High speed mode to / from Low Power Mode Timing

DSI Clock Burst – High speed mode to /from Low Power Mode Timing

Signal	Symbol	Parameter	Specification			Unit	Notes
			MIN	TYP	MAX		
CKP/N	TCLK-POST	Time that the MCU shall continue sending HS clock after the last associated Data Lanes has transitioned to LP mode	60+52*UI			nS	
CKP/N	TCLK-TRAIL	Time to drive HS differential state after last payload clock bit of a HS transmission burst	60			nS	
CKP/N	THS-EXIT	Time to drive LP-11 after HS burst	100			nS	
CKP/N	TCLK-PREPARE	Time to drive LP-00 to prepare for HS transmission	38		95	nS	
CKP/N	TCLK-TERM-EN	Time-out at Clock Lane to enable HS termination			38	nS	
CKP/N	TCLK-PREPARE+TCLK-ZERO	Minimum lead HS-0 drive period before starting Clock	300			nS	
CKP/N	TCLK-PRE	Time that the HS clock shall be driven prior to any associated Data Lane beginning the transition from LP to HS mode	8*UI			nS	

5.2 MCU Interface Characteristics

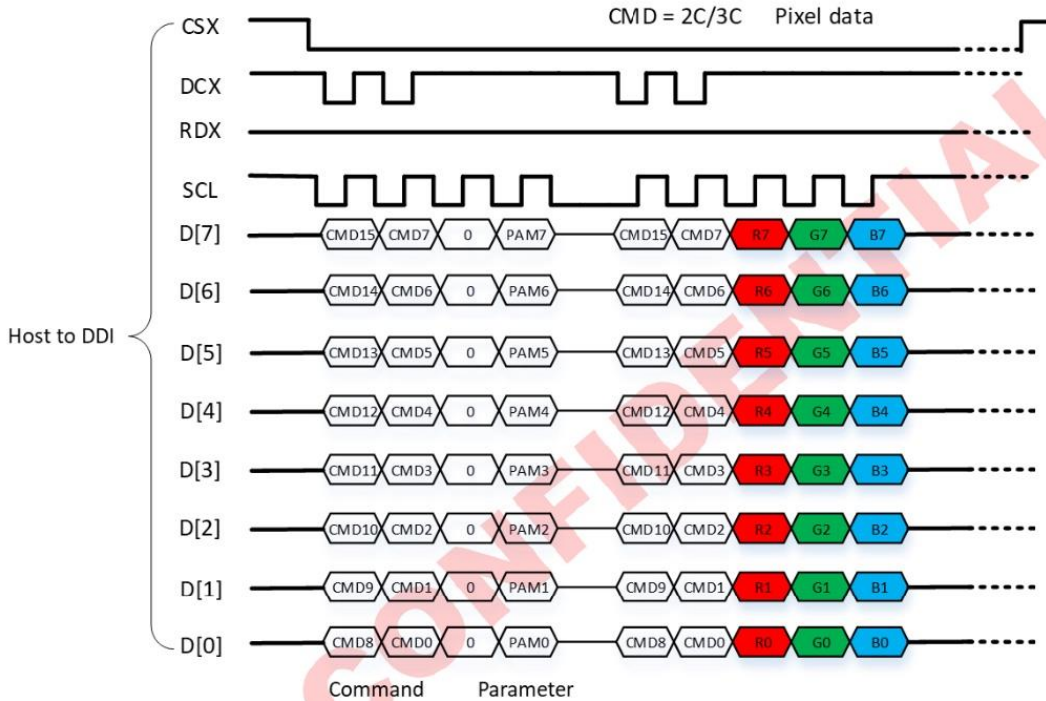

5.3 QSPI Interface Characteristics

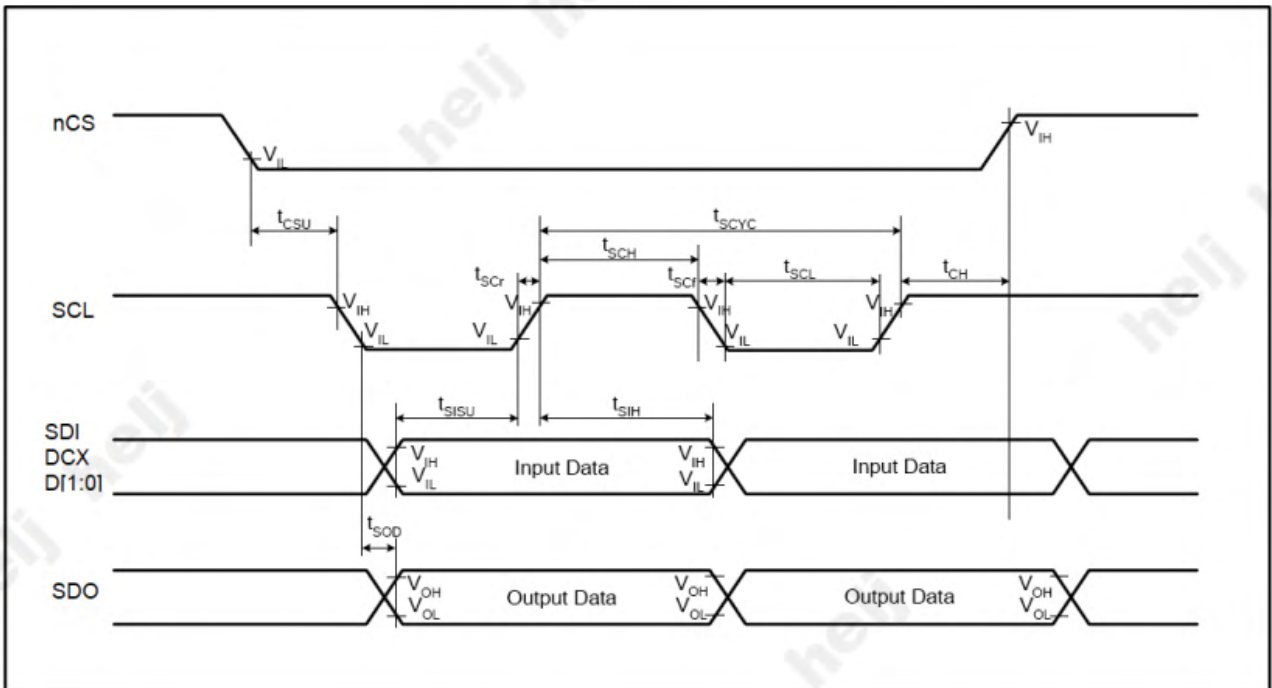

Parameter	Symbol	Conditions	Specification			Unit	Notes
			MIN	TYP	MAX		
SCL	T _{SCYC}	Clock cycle (Write)	20	-	-	ns	
	T _{SCYC}	Clock cycle (Read)	100	-	-	ns	
	T _{SCH}	Clock "H" pulse width (Write)	6.5	-	-	ns	
	T _{SCH}	Clock "H" pulse width (Read)	45	-	-	ns	
	T _{SCL}	Clock "L" pulse width (Write)	6.5	-	-	ns	
	T _{SCL}	Clock "L" pulse width (Read)	45	-	-	ns	
	T _{SCR}	Clock rise time	-	-	3.5	ns	
	T _{SCF}	Clock fall time	-	-	3.5	ns	
CSX	T _{CSU}	Chip select setup time	10	-	-	ns	
	T _{CH}	Chip select hold time	10	-	-	ns	
SDI DCX D[1:0]	T _{SISU}	Data input setup time	4	-	-	ns	
	T _{SIH}	Data input hold time	4	-	-	ns	
SDO	T _{SOD}	Data output setup time	-	-	45	ns	
	T _{SOH}	Data output hold time	5	-	-	ns	

Note 1: Logic high and low levels are specified as 20% and 80% of VDDI for Input signals.

Note 2: Ta = -30 to 85 °C, VDDI=1.65V to 3.3V, VCI=2.7V to 3.6V, GND=0V

Note 3: The max SCL sequence of 4-wire QSPI transferring RGB888, RGB666 and RGB555 is 50Mhz.

5.4 Display RESET Timing Characteristics

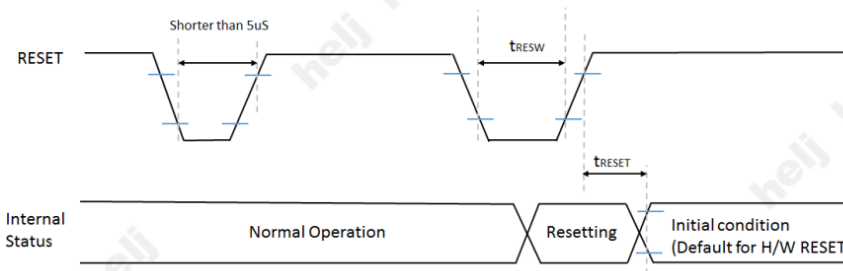

Reset Input Timing

Condition : Ta =25°C

Reset Input Timing

Signal	Symbol	Parameter	Description	Specification			Unit	Notes
				MIN	TYP	MAX		
RESET	t _{RESW}	Reset "L" pulse width		10			µS	1
	t _{RESET}	Reset complete time	When reset applied during Sleep in mode			5	mS	2
			When reset applied during Sleep Out mode			120	mS	5

Note 1: Spike due to an electrostatic discharge on RESET line does not cause irregular system reset according to the table below.

Reset Input Actions

RESET Pulse	Action
Short than 5us	Reset Rejected
Long than 10 μ S	Reset
Between 5us and 10 μ S	Reset Start

Note 2: During the resetting period, the display will be blanked (The display is entering blanking sequence, which maximum time is 120ms, when Reset Starts in sleep out mode. The display remains the blank state in sleep in mode) and then return to Default condition for H/W RESET.

Note3: During Reset Complete Time, values in OTP memory will be latched to internal register during this period. This loading

is done every time when there is H/W RESET complete time(t_{RESET}) within 5ms after a rising edge of RESET.

Note4: Spike Rejection also applies during a valid reset pulse as shown below.

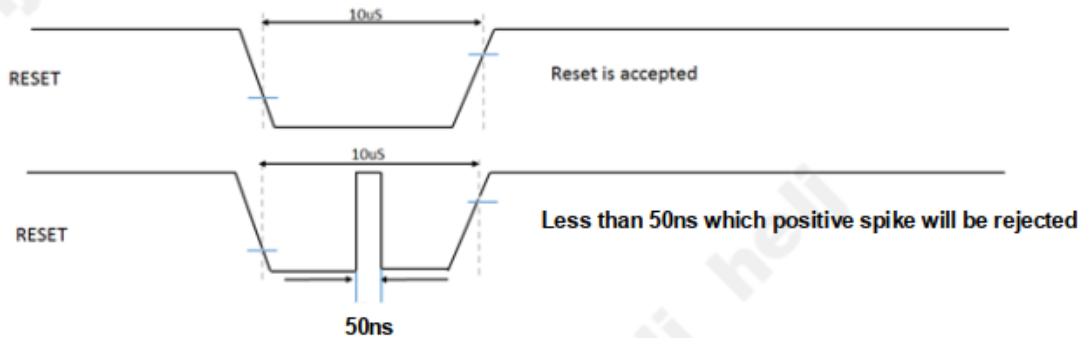

Note5: It is necessary to wait 5ms after releasing RESET before sending commands. Also Sleep Out command cannot be sent for 120msec.

6 Recommended Operating Sequence

6.1 Display Power on Sequence

≡ Power on sequence-MIPI

Symbol	Description	Value			Unit	Remark
		Min.	Typ.	Max.		
Ton1	VDDI on to VCI on delay	≥0	-	-	us	
T1	VCI on to valid to nREST high	10	-	-	ms	
T2	VCI to MIPI bus ready delay	0	-	T1	ms	
T3	RESET low period	50	-	-	us	
T4	nREST high to OTP code reload ready	10	-	-	ms	
T5	Sleep-out command received to display on command received	60	-	-	ms	
Tr1	VDDI power rising time	0.3	-	2	ms	
Tr3	VCI power rising time	0.3	-	2	ms	

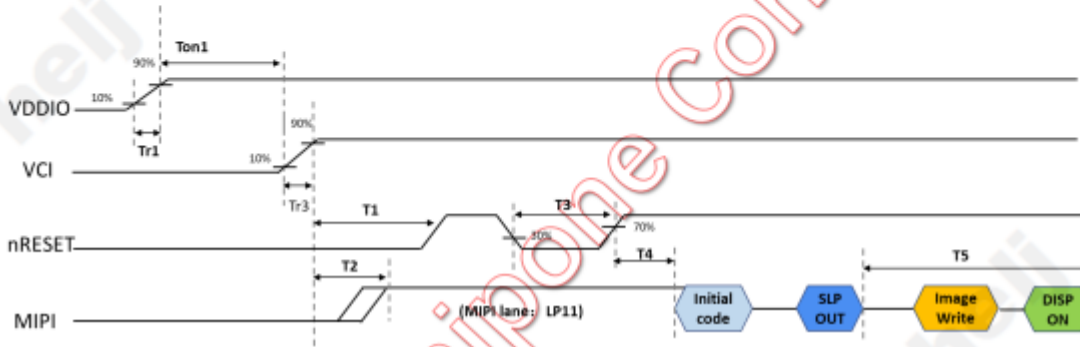

≡ Power on sequence-SPI

Symbol	Description	Value			Unit	Remark
		Min.	Typ.	Max.		
Ton1	VDDI on to VCI on delay	≥0	-	-	us	
T1	VCI on to valid to nREST high	10	-	-	ms	
T3	RESET low period	50	-	-	us	
T4	nREST high to OTP code reload ready	10	-	-	ms	
T5	Sleep-out command received to display on command received	60	-	-	ms	
Tr1	VDDI power rising time	0.3	-	2	ms	
Tr3	VCI power rising time	0.3	-	2	ms	

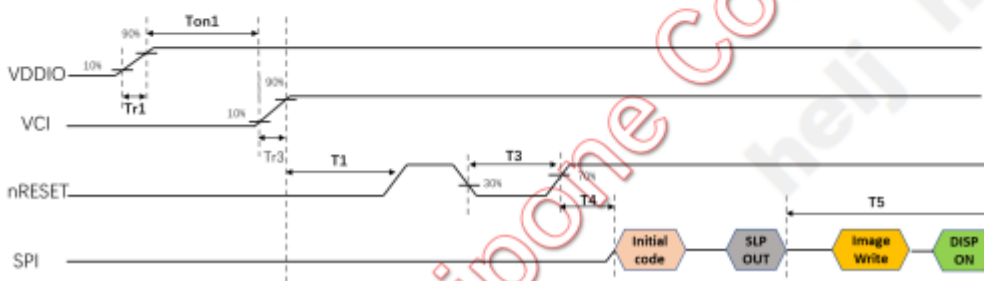

Power on sequence-MCU

Symbol	Description	Value			Unit	Remark
		Min.	Typ.	Max.		
Ton1	VDDI on to VCI on delay	>0	-	-	us	
T1	VCI on to valid to nREST high	10	-	-	ms	
T3	RESET low period	50	-	-	us	
T4	nREST high to OTP code reload ready	10	-	-	ms	
T5	Sleep-out command received to display on command received	60	-	-	ms	
Tr1	VDDI power rising time	0.3	-	2	ms	
Tr3	VCI power rising time	0.3	-	2	ms	

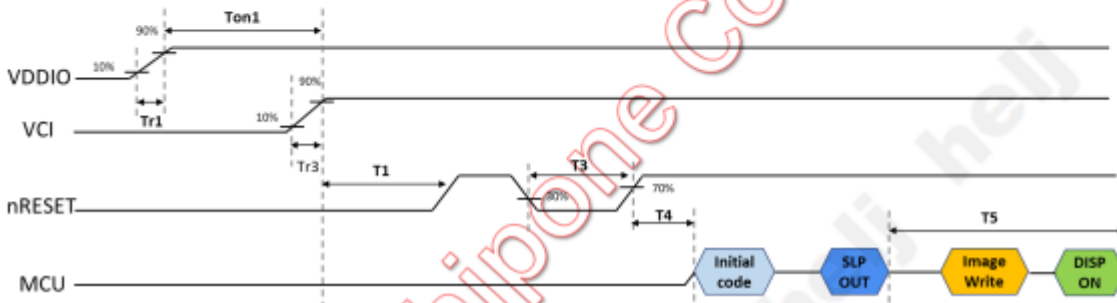

6.2 Display Power off Sequence

Power off sequence-MIPI

Symbol	Description	Value			Unit	Remark
		Min.	Typ.	Max.		
Toff2	VCI off to VDDI off delay	> 0	-	-	us	
T7	Sleep In command received to valid to nREST low	100	-	-	ms	
T8	MIPI ultra low power mode to valid to nREST low	0	-	-	us	
T9	nREST low to VCI off delay	0	-	-	us	
Tt1	VDDI Power falling time	0.1	-	5	ms	
Tt3	VCI Power falling time	0.1	-	5	ms	

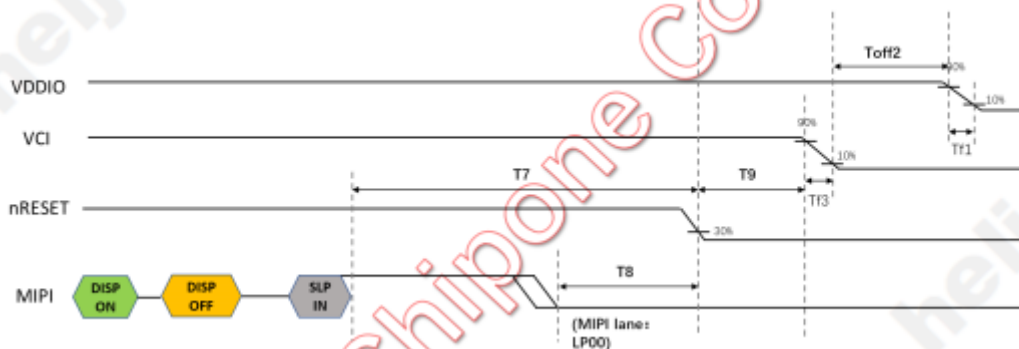

Power off sequence-SPI

Symbol	Description	Value			Unit	Remark
		Min.	Typ.	Max.		
Toff2	VCI off to VDDI off delay	>0	-	-	us	
T7	Sleep In command received to valid to nREST low	100	-	-	ms	
T9	nREST low to VCI off delay	0	-	-	us	
Tf1	VDDI Power falling time	0.1	-	5	ms	
Tf3	VCI Power falling time	0.1	-	5	ms	

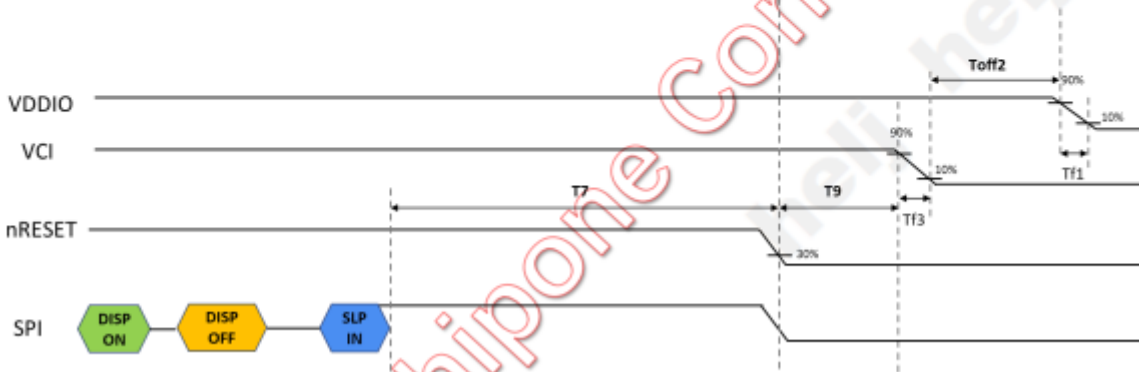

Power off sequence-MCU

Symbol	Description	Value			Unit	Remark
		Min.	Typ.	Max.		
Toff2	VCI off to VDDI off delay	>0	-	-	us	
T7	Sleep In command received to valid to nREST low	100	-	-	ms	
T9	nREST low to VCI off delay	0	-	-	us	
Tf1	VDDI Power falling time	0.1	-	5	ms	
Tf3	VCI Power falling time	0.1	-	5	ms	

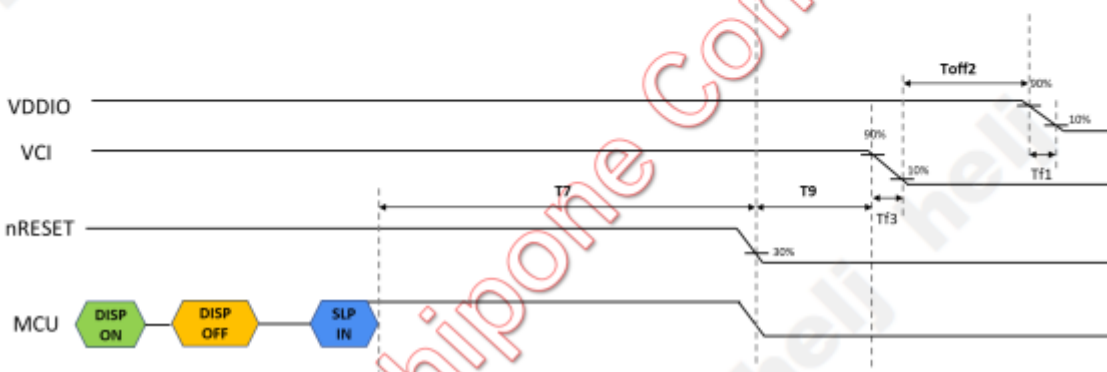



7 Optical Characteristics Optical Specification

Item	Symbol	Condition	Min	Typ	Max	Unit	Remark
View Angle	θT	CR≥10	80			Degree	Note 2 Test Equipment:CS2000A
	θB		80				
	θL		80				
	θR		80				
Contrast Ratio	CR	θ=0°	100,000				Note1 Note3 Test Equipment:CS2000A
Chromaticity	White	x	(0.280)	(0.300)	(0.320)		Note 4 Test Equipment:CS2000A Note: Chromaticity can be modified according to customer demand
		y	(0.295)	(0.315)	(0.335)		
	Red	x	(0.652)	(0.682)	(0.712)		
		y	(0.285)	(0.315)	(0.345)		
	Green	x	(0.200)	(0.240)	(0.280)		
		y	(0.676)	(0.716)	(0.756)		
	Blue	x	(0.108)	(0.138)	(0.168)		
		y	(0.016)	(0.046)	(0.076)		
Uniformity	U		85			%	Note1 Note5 Test Equipment:CS2000A
NTSC				100		%	Note4
Normal-Luminance	L		765	850	935	Cd/m ²	Note1 Note6 Test Equipment:CS2000A
HBM-Luminance	L		900	1000	1100	Cd/m ²	Note1 Note6 Test Equipment:CS2000A
Color temperature			6500	7000	7500	T	Note1 Note6 Test Equipment:CS2000A
Flicker					-40	dB	Note8 Test Equipment:CA310

							(Green127 60HZ)
Cross-talk					2	%	Note7 Test Equipment:CS2000A

* Reference value.

Test Conditions:

1. the ambient temperature is 25°C.
2. The test systems refer to Note1 and Note2.

Note 1: Definition of optical measurement system.

The optical characteristics should be measured in dark room. The optical properties are measured at the center point of the AMOLED screen. All input terminals AMOLED panel must be ground when measuring the center area of the panel.

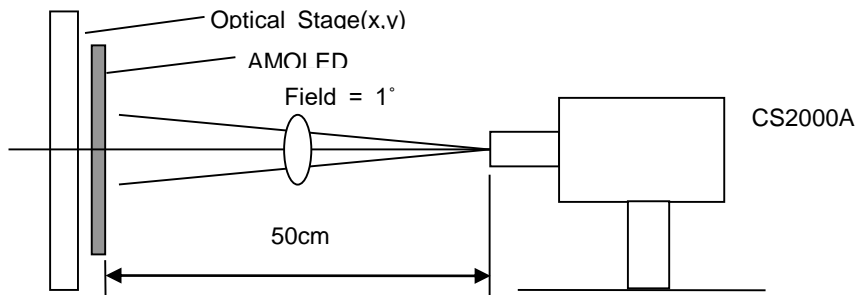

Optical Characteristic Measurement Equipment and Method

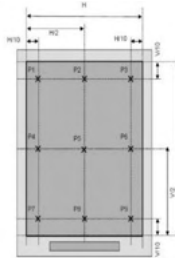

Measuring point for surface luminance

Note 2: Definition of viewing angle range and measurement system.

SPEC TITLE

DOCUMENT CONTROL SPECIFICATION

EFFECTIVE DATE: 2025-03-27

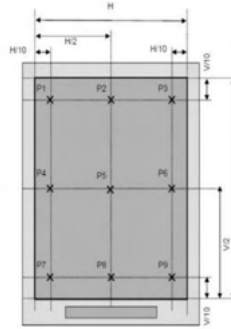

Definition of uniformity

Lmax: The measured maximum luminance of all measurement position.

Lmin: The measured minimum luminance of all measurement position.

Note 6: Definition of luminance:

Measure the luminance of white state at center point.

Note 7: Cross Talk

A. Measure luminance at the position, P0.

B. Calculate cross talk as below equation.

$$L_{W_OFF} = \frac{L_{W1} + L_{W2} + L_{W3} + L_{W4}}{4}$$

$$L_{B_OFF} = \frac{L_{B1} + L_{B2} + L_{B3} + L_{B4}}{4}$$

$$\text{crosstalk} = \frac{|L_{Wi_ON} - L_{W_OFF}|}{L_{W_OFF}} \times 100\% \quad (i = 5 \text{ to } 8)$$

$$\text{crosstalk} = \frac{|L_{Bi_ON} - L_{B_OFF}|}{L_{B_OFF}} \times 100\% \quad (i = 5 \text{ to } 8)$$

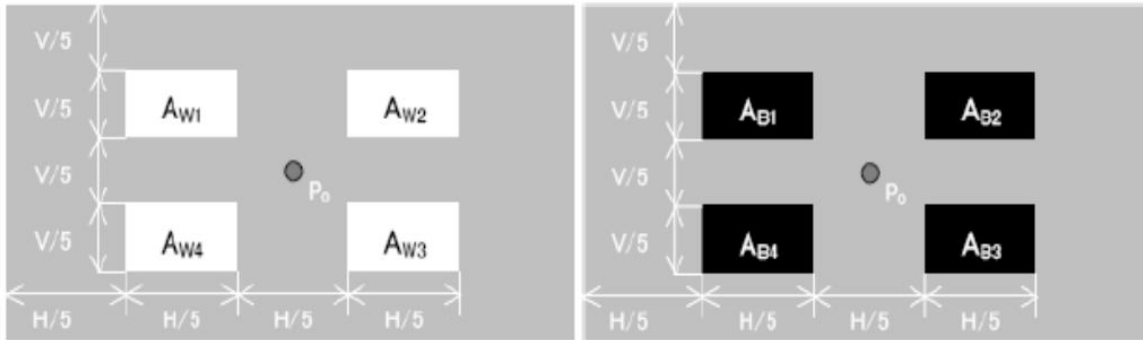

(a) L_{W_OFF} , L_{B_OFF} measuring pattern

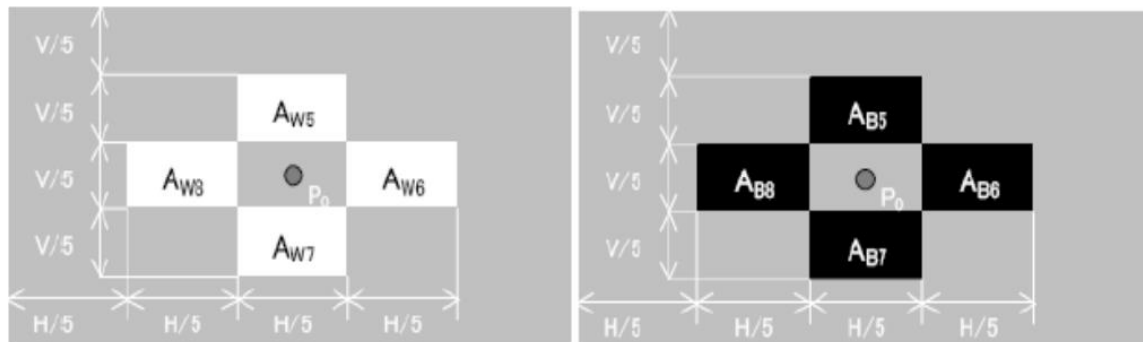

(b) L_{W_ON} , L_{B_ON} measuring pattern

Note 8: Flicker

Adjust the sample to Green127 at 60Hz @800nit, measure Flicker value by JEITA with CA310.

8 Environmental /Reliability Test

No	Test Item	Condition	Remark
1	High Temperature & High Humidity Operation	60°C, 90% RH,240hrs	IEC 62341-5:2009
2	High Temperature Operation	70°C, 240hrs	IEC 62341-5:2009



SPEC TITLE

DOCUMENT CONTROL SPECIFICATION

EFFECTIVE DATE: 2025-03-27

3	Low Temperature Operation	-20℃, 240hrs	IEC 62341-5:2009
4	High Temperature Storage	80℃, 240hrs	IEC 62341-5:2009
5	Low Temperature Storage	-40℃, 240hrs	IEC 62341-5:2009
6	Thermal Shock	-40℃ (30min) ~80℃ (30min) Change time: 10min 100cycle	IEC 62341-5:2009

Note: Product reliability items in the form of GC are used as reference items. The test results shall refer to the results of the reliability test of Visionox standards.

9 Quality Level

9.1 Definition and description

9.1.1 Critical Defect: Any defect that directly or indirectly affects personal health and safety, or causes a loss of functionality in the product's function list.

9.1.2 Major Defects: Defects that directly or indirectly affect the functionality of the product, or result in partial loss of functionality, and other defects that cannot be accepted by customers (including a collection of three or more minor defects).

9.1.3 Minor Defects: Appearance defects that do not affect product functionality and are still acceptable to customers.

9.2 Execution level

9.2.1 Sampling standard: The sampling scheme of (GB/T2828.1 2012) normal inspection was adopted.

9.2.2 Check item and frequency

General item	telecommunication /appearance	Telecommunication inspection standard & Visual inspection criteria	Critical Defect (CR Not allowed);	/
--------------	-------------------------------	--	-------------------------------------	---



			Major Defects (MA AQL 0.65); Minor Defects (MI AQL 1.0);	
Special item	Optical test	Product specification	5PCS/ work order or according to customer requirements	-
	Dimensional measurement	drawing	5PCS/ work order or according to customer requirements	Meet the requirements of drawings (spot check key dimensions); Meet the requirements of the sample acknowledgment.

9.2.3 Number of defects criterion decide CR=CR,MA=CR +MA,MI=CR +MA+ MI.

9.2.4 When a product has two flaws, More serious defect judgment .

9.2.5 Manufacturing department functional test and appearance inspection perform full inspection,The quality department shall execute as above 5.2.1~ 5.2.4.

9.3 content

9.3.1 Inspector qualification:Inspectors must be trained and obtain a job certificate before they can inspect products.

9.3.2 Inspection condition:OLED does not light the light source 1000±200lux ;OLED light source is not higher than 200LUX,Surrounded by a black background.

9.3.3 Inspection distance:The standard viewing distance for all surfaces of the detected object

is 30CM±5CM.

9.3.4 Inspection perspective :The angle between the product and the horizontal plane is 45°,and the eyes are perpendicular to the inspection plane. During inspection the product needs to rotate 45°up,down,left and right. The observation line of sight needs to be within the half section of the cone. The observation angle is 45° with the vertical axis of the product apex. The central axis of the cone must be standard andperpendicular to the product surface and pass through the fluorescent lamp;For non-conventional display defects (including but not limited to local bright lines or local floodlights),the observation angle is 75degrees from the normal of the product surface;Full visual angle ofappearance..

9.3.5 Inspection time:the inspection time without lighting is at least 10-12 seconds; The time of OLED lighting inspection for each picture is 1~3 seconds.

9.3.6 Test temperature:room temperatuer15-35°C,ambient humidity:20-75%RH.

9.3.7 Inspection picture:

If there are no special requirements, refer to the pass Angle inspection screen library, if each model has special requirements, it is combined with customer requirements and the needs of the factory process assessment.

9.4 Inspection tools:

9.4.1 ND Filter:The ND filter is placed at a distance of 2-3cm above the defect for2-3S to judge whether the defect is visible. As Figure below:(ND Filter is used to test mura isochromatic and light unevenness) .

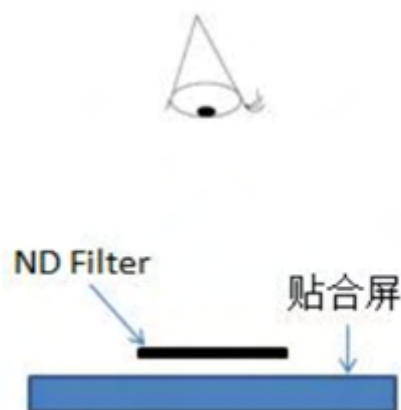

9.4.2 Point gauge(point gauge in the figure below is recommended),determination method: as shown in the figure, the point gauge film can cover is pass, and the point gauge film can not cover is Fail.For example, a maximum of 0.2mm same-color spot defect is allowed on the Class A surface, and the pass that can be covered by 0.2mm on the film, The one that can be covered

is Fail

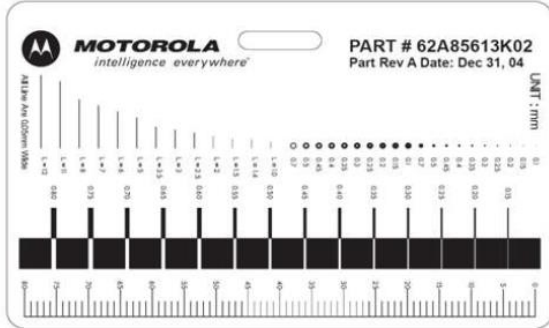

Imperfections of various shapes



Inspection Dot



Pass: Imperfection is smaller than the inspection dot



Fail: Imperfection is larger than the inspection dot

9.4.3 Microscopic examination: use 20-50 times adjustable microscope and 10-30 times test eyepiece.

9.4.4 Digital caliper: resolution 0.01mm.

9.4.5 Projector: anime microscope,3D projector.

9.5 Judgment description

9.5.1 The measurement accuracy shall refer to the specification definition. When the measurement equipment accuracy is higher than the specification definition, the measured value needs to be rounded to the size of edge collapse is 0.20mm,and the thousandth is the reference position, which is rounded to 0.200~0.204mm is ok, ≥ 0.205 mm, it is judged al NG.



9.5.2 In addition to the tools used above, if additional inspection tools are needed to assist The judgment, they can only be carried out after the coordination of both parties.



9.5.3 Bad code and definition



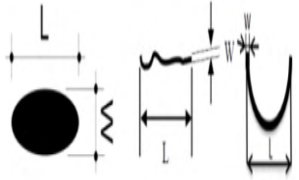

9.6 Inspection standard

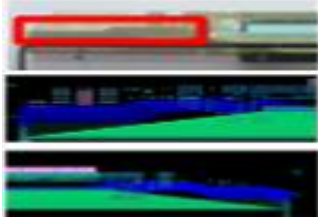
9.6.1 Telecommunications Inspection Item:

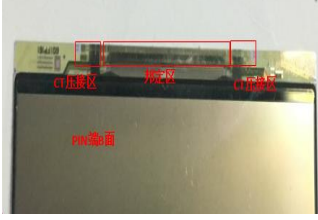
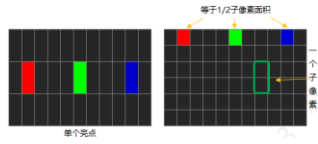
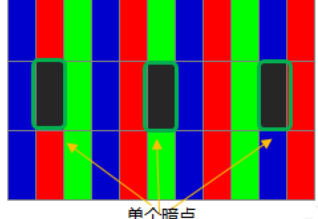
Code and name		legend	explain
N	Number	-	Visually calculate the number; The statistics of the total number of defects does not include the

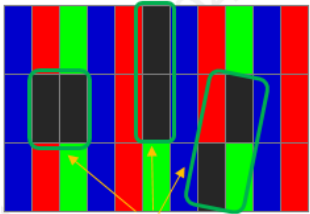
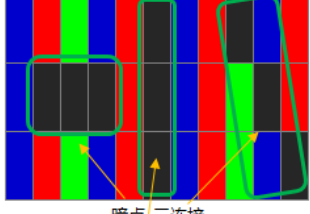
			completely "omitted" part. For the column defined as "omitted" and "omitted", it is not counted as the number of defects if it meets the requirements, otherwise it is calculated as an independent defect.
L	Length (mm)		Dot line distinguishing rule: L is the long side, W is the short side
W	Width (mm)		A. When $L > 3W$, handle as per line, otherwise handle as per point; B. When it is judged as line defect, S-shaped or C-shaped line appears, and the enclosed amount is less than 3/4 circle, it shall be treated as line defect; otherwise, it shall be treated as point defect, and the inner tangent circle shall simulate the size of point.
S	Area (mm ²)	-	Surface gauge
D	Diameter (mm) $D=(L+W)/2$	-	Point diameter calculation: calculated by half of the sum of the long side and the short side, that is, $D=(L+W)/2$, where D represents the diameter of the point, L is the long side, and W is the short side;
H	Depth (mm)	-	Digital micrometer
DS	Distance (mm)		Distance between two points or between two lines
Schematic diagram of screen area			AA area: display area; GA area: GIP circuit area; FA area: Frit area; OA area: outside FA area

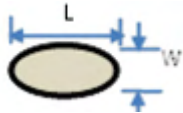
<p>Leader area</p>		<p>Screen GIP circuit area, screen data circuit area</p>
<p>PAD Bonding District</p>		<p>COG/FOG Bonding alignment mark and Bonding Pad on LTPS substrate</p>
<p>PAD Non-state area</p>		<p>Screen test pad, cutting area and lead-free area on LTPS substrate</p>
<p>CT crimping area</p>		<p>Pin end screen test pad</p>
<p>Highlights</p>		<p>A single sub-pixel (or red, or green, or blue) of one pixel is called a point; The definition of bright spot is that in the environment of 200 ± 50 Lux, the pixels or dots seen by employees with naked eyes are always bright, and the bright spot is checked under the black screen</p>
<p>Scotoma</p>		<p>A single sub-pixel (or red, or green, or blue) of one pixel is called a point; A dark point is defined as a point that is not bright in a single sub-pixel seen with naked eyes in a 100% white picture under the environment of 200 ± 50 Lux.</p>

<p>Dark spot - two connection</p>	 <p>暗点-二连接</p>	<p>Two adjacent sub-pixels under the magnifying glass are not bright at the same time (horizontal, vertical and oblique)</p>
<p>Dark Spot - Three Links</p>	 <p>暗点-三连接</p>	<p>The adjacent R, G and B sub-pixels under the magnifying glass are not bright at the same time (horizontal, vertical and oblique)</p>
<p>CG monomer area division</p>		<p>AA: Front visible area, black ink internal area; A: Black ink area; B: Cover plate edge;</p> <p>The front defect that runs through the AA area and the A area shall be judged according to the specification of the strictest area, and the back defect shall be judged according to whether the AA area is visible.</p>
<p>Foreign matter highlights</p>	<p>-</p>	<p>Due to the foreign matter in the polarizer, the phenomenon that appears as a bright spot is called a foreign matter bright spot</p>
<p>point defect</p>		<p>There are bright spots and black spots in local positions, including but not limited to the internal dirt of the screen itself, pinholes, serrations, concave-convex spots, color spots, tiny bubbles, white spots, stains on the fitting of the polarizer, poor polarizer itself and other spot-like defects. Point defects are judged by diameter.</p>
<p>Linear defect</p>		<p>Linear impurities in the screen, including filaments, fibers, polarizer fitting impurities in the screen, and scratches on the surface of polarizer, etc. Linear defects are judged by length and width.</p>

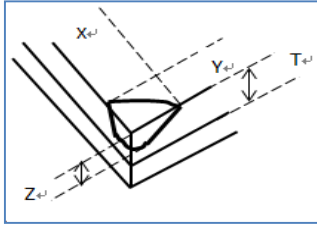
		<p>Sensible scratch: also known as hard scratch, is a deep scratch on the surface, which is felt by hand.</p> <p>Senseless scratch: also known as fine scratch, no deep scratch on the surface, no feeling when touching.</p>
Serrated defect		W: Distance from sawtooth crest to trough
Edge collapse/angle collapse		<p>In the process of screen production, especially in the process of molding and cutting, the small glass missing at the glass edge is caused.</p> <p>X direction: parallel to FOG Pad or glass edge; Y direction: perpendicular to FOG Pad or glass edge; Z direction: screen thickness direction;</p>
Pitting	-	In the unit area of 10mm * 10mm, the defect point with $D \leq 0.1\text{mm}$, $DS \geq 2\text{mm}$, and the number $N \geq 5$. If the customer has other requirements, follow the customer's requirements.
Dirty	-	<p>Including handprints, oil stains, fingerprints, stains, white fog and other undesirable phenomena. It is divided into erasable dirt and non-erasable dirt. Use a dust-free cloth dipped in alcohol, which can not be erased as non-erasable dirt. Wipable dirt is determined as follows:</p> <p>A. Dry dust-free cloth can be directly erased; B. Wipe with clean cloth dipped with anhydrous alcohol</p> <p>Press the alcohol-stained dust-free cloth on the dry dust-free cloth twice to absorb excess alcohol; Wipe back and forth with a dust-free cloth twice, and the dirt can be removed.</p>



9.7 Telecommunication inspection standard

类别	序号	检查项目	区域	检验规格	检验方式	缺陷类型
功能不良	1	显示异常	AA	不允许	目视	致命
	2	无显	AA	不允许	目视	致命
TP功能	3	TP 测试 NG	AA	不允许	目视	主缺
点类	4	亮点	AA	不允许	目视	主缺
	5	暗点	AA	1、 $D \leq 0.15\text{mm}$, 忽略 ; 2、 $0.15 < D \leq 0.2\text{mm}$, $DS \geq 10\text{mm}$, $N \leq 10$; 3、 $D > 0.2\text{mm}$, 不允许 ; 注 : 结合 PPI , 根据子像素尺寸定义	目视 / 目镜 / 菲林 卡	次缺
线类	6	亮线	AA	不允许	目视	致命
	7	暗线	AA	不允许	目视	主缺
	8	微亮线	AA	不允许	目视	主缺
光学不良	9	光学测试 NG	AA	不满足白平衡/规格书/承认书等光学测试要求不允许	光学测试仪	主缺
Mura类	10	条纹 mura (横向/竖向/斜向)	AA	1、 64/127/白画面/ R/G/B ND5%判定, 不可见为 OK , 可见为 NG。 2、 参考限样 (生产时收集边缘规格样品	目视、 限样	次缺
	11	白斑	AA			



	12	黑斑	AA	同客户议定(标样 2pcs 及规格外样品))。		
	13	彩色 mura	AA			
	14	牛顿环 mura	AA			
	15	过渡不均	AA			
	16	其他 mura	AA			
注：1、mura 类指定画面判定；2、有限样优先参考限样。						
异物 点/ 线类	17	点状缺陷 (异物, 黑白 点, 划伤, 气泡 等)	AA	1、 $D \leq 0.1\text{mm}$, $DS \geq 2\text{mm}$, 忽略； 2、 $0.1 < D \leq 0.15\text{mm}$, $N \leq 1$ ； 3、 $D > 0.15\text{mm}$, 不允许；	目 视、 菲林 卡	次缺
	18	线状缺陷 (异物线, 划 伤, 气泡等)	AA	1、 $W \leq 0.03\text{mm}$, $L \leq 2\text{mm}$, $DS \geq 2\text{mm}$, 不 计； 2、 $0.03\text{mm} < W \leq 0.05\text{mm}$, $L < 2\text{mm}$, $DS \geq 2\text{mm}$, 不计； 3、 $0.03\text{mm} < W \leq 0.05\text{mm}$, $2\text{mm} < L \leq 3\text{mm}$, $DS \geq 2\text{mm}$, $N \leq 4$ ； 4、 $W > 0.05\text{mm}$ 或 $L > 3\text{mm}$, 不允许；	目 视、 菲林 卡	次缺



9.7.1 Appearance inspection standard

类别	序号	检查项目	区域	检验标准	检验方式	缺陷类型
Panel	1	屏体脏污/笔迹	All	1、正面（B面）可擦拭脏污擦除，不可擦拭脏污不允许； 2、背面（A面）不管控；	目视	次缺
	2	崩边/角	PAD 非 bonding 区	1、 $Y \leq 0.1\text{mm}$ ，X&N 不计； 2、 $0.1\text{mm} \leq Y \leq 0.4\text{mm}$ ， $X \leq 2\text{mm}$ ，N 不计； 3、 $Z \leq t$ ； 4、B面即正面不可伤及 mark；	目视/菲林卡	次缺
			PAD bonding 区	1、切割未整体伤及 Pad 和线路； 2、Y 不伤及 Pad 1/4，X&N 不计； 3、模组绑定后玻璃背面崩缺在不影响功能、性能、可靠性等情况下， $Y \leq 0.4\text{mm}$ ，X&N 不计；		
			OA 区	1、 $Y \leq 0.15\text{mm}$ ，X 和 N 不计； 2、 $0.15\text{mm} < Y \leq 0.4\text{mm}$ ， $X \leq 2\text{mm}$ ； 3、 $Y > 0.4\text{mm}$ ，不允许； 4、 $Z \leq t$ ，不伤及 Frit（Frit 上方玻璃 chiping 规格卡控 X/Y）；		
3	凸点	AA	有触感不允许	目视	次缺	



	4	凸缘	OA	符合设计图纸规范情况下： 1、 $Y \leq 0.1\text{mm}$ ，X 不管控； 2、 $Y > 0.1\text{mm}$ ，不允许	目视、菲林卡	次缺
	5	Mark 缺损	Pin 端	影响到机台对位的 mark 缺损不允许	目视	次缺
	6	破片	All	不允许	目视	次缺
	7	裂纹	All	不允许	目视	次缺
	8	屏体翘曲	All	产品正面和反面分别平放一端翘起高度 (塞规) $\leq 0.6\text{mm}$	目视/塞规	次缺
异物 点线 类	9	点状缺陷 (异物, 黑白点, 划伤, 气泡等)	All	1、 $D \leq 0.1\text{mm}$ ，忽略；密集麻点不允许 2、 $0.1\text{mm} < D \leq 0.15\text{mm}$ ， $N \leq 1$ ， $DS > 2\text{mm}$ ； 3、 $0.15\text{mm} < D \leq 0.20\text{mm}$ ， $N \leq 1$ ； 3、 $D > 0.2\text{mm}$ ，不允许；	目视、菲林卡	次缺
	10	线状缺陷 (异物线, 划伤, 气泡等)	All	1、 $W \leq 0.03\text{mm}$ ， $L \leq 2\text{mm}$ ， $DS \geq 2\text{mm}$ ，不计； 2、 $0.03\text{mm} < W \leq 0.05\text{mm}$ ， $L < 2\text{mm}$ ， $DS \geq 2\text{mm}$ ，不计； 3、 $0.03\text{mm} < W \leq 0.05\text{mm}$ ， $2\text{mm} < L \leq 3\text{mm}$ ， $DS \geq 2\text{mm}$ ， $N \leq 4$ ； 4、 $W > 0.05\text{mm}$ 或 $L > 3\text{mm}$ ，不允许；	目视、菲林卡	次缺



保护膜	11	保护膜本体不良	All	CG 保护膜、摄像孔保护膜、焊盘保护膜、撕离把手等： 1、不允许翘起、脱落、功能无效、破损、漏贴不允许； 2、气泡、褶皱、凹凸点、脏污、毛边、溢胶等不伤及本体不管控； 3、FPC 上电子元器件保护膜，正视看不漏元器件，脱落不允许，不超出屏幕外形。	目视	次缺
	12	偏位	All	满足设计图纸等规格，且外观检目视不超出屏幕外形	目视	次缺
偏光片	13	偏光片边缘溢胶	AA	1、 $W \leq 0.1\text{mm}$ ，不管控； 2、 $W > 0.1\text{mm}$ ，不允许；	目视/菲林卡	次缺
	14	偏光片划伤	AA	未伤及本体不管控，伤及本体按点线类标准	目视	次缺
	15	偏光片凹凸点	AA	贴合后不可见 OK，贴合后可见参照点规，有限度样时参照限度样	目视/菲林卡	次缺
	16	偏光片气泡线	All	AA 区以外 0.15mm 以内不允许	目视/菲林卡	次缺
	17	偏光片折/压痕	AA	1、不影响功能显示。 2、目视可按点/线规格判定或参考限样	目视	次缺
	18	偏光片边缘溢胶导致翘曲	AA	不可延伸至 AA 区	目视	次缺
IC/COF	19	IC 破损	All	目视可见不允许	目视	主缺
	20	COF PI 面划伤	COF PI	1、PI 面划伤不得影响正面线路(如变形、损伤、折痕)，不影响功能性能为 OK。	目视	次缺



				2、PI 面表面折痕、压痕、压伤不允许不影响功能性能为 OK。		
	21	IC/COF 其他	All	参考 IC/COF 设计图纸及材料规格书	目视	主缺
FPC	22	FPC 本体不良	All	不影响功能即可	目视	次缺
	23	FPC 金手指不良	金手指区域	1、金手指龟裂：金手指顶端龟裂/破损的长度和宽度≤线宽； 2、金手指漏铜：W≤1/3 线宽，L≤线宽，数量不限 3、金手指缺口 W1≤1/3 线宽 W，长度 L1≤1/2 线宽 W，数量不限，以上条件全部满足允许； 4、金手指压伤/划伤不可露铜，不可有凹凸感，肉眼目视无深度，不影响组装，可接受； 5、金手指不可有锐角褶皱及死折现象； 6、FPC 金手指不可有氧化发黑、烫伤，变褐色；	目视	次缺
	24	连接器	连接器	连接器上不能有沾锡或残留锡珠现象、连接器焊脚不能有连锡现象；PIN 变形量按不超过 0.05mm 管控；不影响点亮功能；目视观看 pin 折、pin 脱落、外框挤压变形不允许；	目视、菲林卡	次缺
	25	FPC 其他	FPC	参考原材料规格书	目视、菲林卡	次缺







组装及其他	26	硅酮胶/高温胶	All	1.硅酮胶溢胶不可超出 0.2mm。 2.高温胶可超出 FPC，但不可上离型膜。 如不涉及此工序规格可不作参考	目视/菲林卡	次缺
	27	封点胶	涂胶区域	1、绑定区域：断胶不可有，IC 和 FPC 上气泡不管控，胶体厚度以不高出 POL 面为准； 2、其它区域：线路区断胶不允许，不可裸露线路，气泡直径 < 1mm，胶体厚度以不高出 POL 面为准； 3、IC 本体、FPC 本体：需完全覆盖、不能出现宽度大于 1mm 带状胶体或者直径大于 2mm 的点状胶体；	目视/菲林卡	次缺
	28	翻折后翘起	All	FPC 与气泡棉间翘起高度≤0.5mm；	目视/菲林卡	次缺
	29	二维码	二维码	不允许无法扫描或不易扫描(连续三次扫描以上方能识别)，外观清晰，无模糊，印刷缺失等不良	扫码器/目视	次缺
外包装缺陷	30	混料	/	所有产品、标签不允许	-	-
	31	脏污、笔迹	All	笔迹残留和笔迹印痕不允许；水/油污残留等不允许	-	-
	32	包装	All	参考包装式样书和工艺 SOP 等规定	-	-



外形尺寸	33	外形尺寸 NG	/	超出规格书图纸要求尺寸及公差 不允许	--	-
------	----	---------	---	--------------------	----	---

9.7.3 Inspection picture library

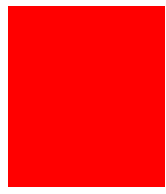
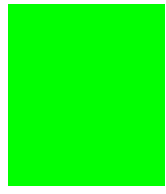
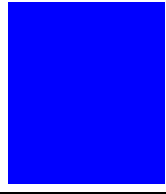
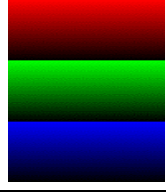
序号	图片	图片名称	主要判定不良	备注
1		HSCALE 水平渐层灰阶	OTP 不良、功能异常	/
2		VSCALE 垂直渐层灰阶	OTP 不良、功能异常	/
3		W_GRAD(64) 64 灰阶	功能不良、亮点/暗点类、线类、Mura 类/显示不均、异物点/线类、常规偏色类	/
4		W_GRAD(128) 128 灰阶	功能不良、亮点/暗点类、线类、Mura 类/显示不均、异物点/线类、常规偏色类	/
5		WHITE 白	功能不良、亮点/暗点类、线类、Mura 类/显示不均、异物点/线类、色彩一致性	/
6		Black 黑	功能不良、线类、亮点类、Mura 类/显示不均	/

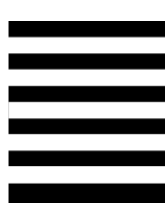
7		HBM WHITE 高亮白	点类、线类、异物点/线	/
8		RED 红	功能不良、亮点/暗点类、线类、Mura 类/显示不均、异物点/线类、色彩一致性	/
9		GREEN 绿	功能不良、亮点/暗点类、线类、Mura 类/显示不均、异物点/线类、色彩一致性	/
10		BLUE 蓝	功能不良、亮点/暗点类、线类、Mura 类/显示不均、异物点/线类、色彩一致性	/
11		RGB3H 3色渐变灰阶	OTP 不良、功能异常	/
12		Complex	微亮线	/
13		WAKU	贴合偏位	/
14		黑白条画面+低 51 值 注：低 51 值为将 51 寄存器赋值，51,00,02，为模拟客户端亮度条拉为最低时状态	闪屏	/

10 Mechanical Drawing

10.1 Overall dimensions of the assembly

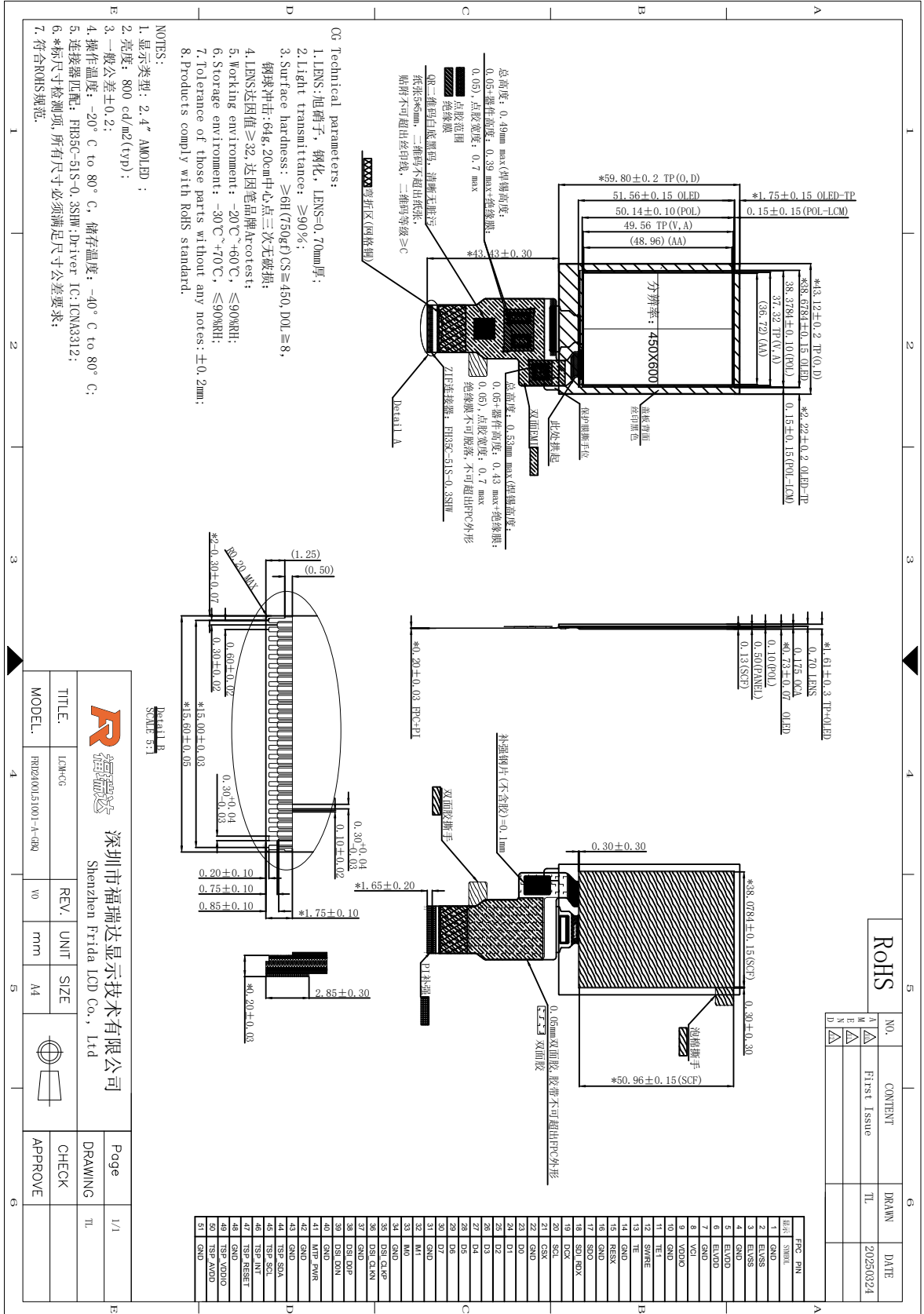



10.2 CG Overall dimensions

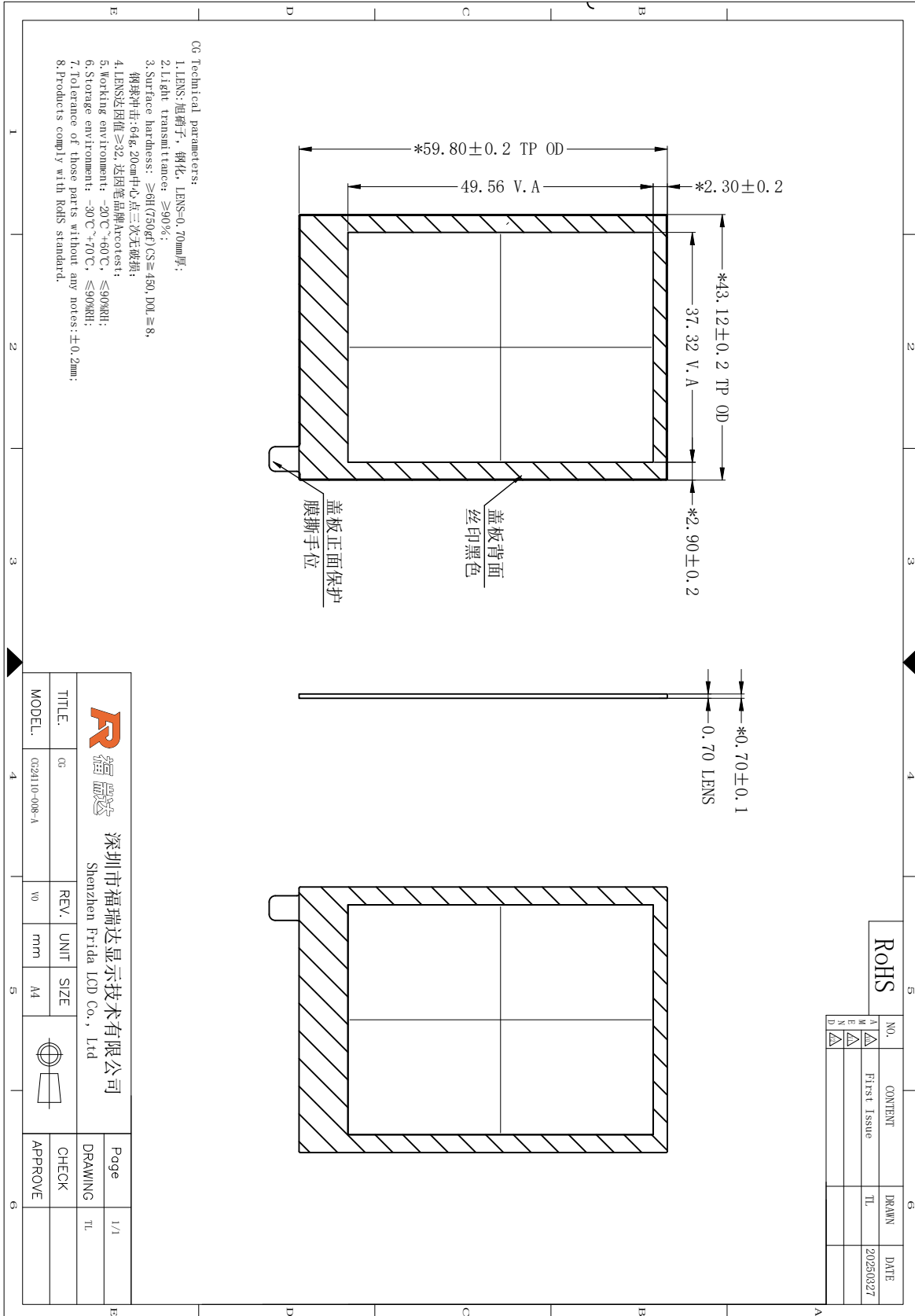



SPEC TITLE

DOCUMENT CONTROL SPECIFICATION

EFFECTIVE DATE: 2025-03-27

11 Precautions for Use of AMOLED Modules

11.1 Handling Precautions:

- 11.1.1 The display panel is made of glass. Do not subject it to a mechanical shock by dropping it from height.
- 11.1.2 Do not press down the screen or the adjoining areas too hard because the color tone may be shifted.
- 11.1.3 The polarizer covering the display surface of the AMOLED module is soft and easily scratched. Handle this polarizer carefully.
- 11.1.4 If the display surface is contaminated, blow on the surface and gently wipe it with a soft dry cloth. If it is still not completely clear, moisten the cloth with ethyl alcohol.
- 11.1.5 Solvents may damage the polarizer. Do not use water, ketone or aromatic solvents except ethyl alcohol. Do not attempt to disassemble the AMOLED Module.
- 11.1.6 If the logic circuit power is off, do not apply the input signals.
- 11.1.7 To prevent destruction from static electricity, be careful to maintain an optimum working environment.
- 11.1.8 Be sure to make yourself in contact with the ground when handling with the AMOLED Modules.
- 11.1.9 Tools required for assembly, such as soldering irons, must be properly ground.
- 11.1.10 To reduce the generation of static electricity, do not conduct assembly or other work under dry conditions.
- 11.1.11 To protect the display surface, the AMOLED Module is coated with a film. Be careful when peeling off this protective film, because static electricity may generate.

11.2 Storage Precautions:

- 11.2.1 When storing the AMOLED modules, be sure that they are not directly exposed to the sunlight or the light of fluorescent lamps.
- 11.2.2 The AMOLED modules should be stored under the storage temperature range. If the AMOLED modules will be stored for a long time, the recommended condition is: temperature: 0°C~40°C Relatively humidity: ≤80%
- 11.2.3 The AMOLED modules should be stored in the room without acid, alkali or harmful gas.

11.3 Transportation Precautions:

- 11.3.1 The AMOLED modules should not be suffered from falling and violent shocking during transportation. Besides, excessive press, water, damp and sunshine, should be avoided.