

# SPECIFICATION

## 产品规格书

NO.(编号) : NCYM-DS-RD

Part No.(型号) : 5050A24-XXN165-U8S1P-V21-TD-LX

Description(描述) : 5050 White LED

Model(说明) : EMC5050 24V CRI70

CUSTOMER APPEROVED (客户审核)	APPROVED (核准)	ISSUED (制定)
	朱磊	王磊

SHINEON (NANCHANG) TECHNOLOGY CO.,LTD

699 Tianxiang Avenue, Building 7-1, CEC Low-Carbon Technology Park, High-Tech  
Development District, Nanchang City, Jiangxi Province, P.R.China  
TEL: 0791-88130119  
<http://www.shineon.cn>

## 5050A24-XXN165-U8S1P-V21-TD-LX Datasheet

This 5050 LED Light Source is a high performance energy efficient device which can handle high thermal and high driving current. The small package outline and high intensity make it an ideal choice for High Bay, tunnel lamp, street lamp outdoor light and etc.

The White Power LED is available in the range of color temperature from 2700K to 6500K.

This part has a foot print that is compatible to most of the same size LED in the market today.



### FEATURES

---

- Available in Cool White, Neutral White and Warm White color
- ANSI-compatible chromaticity bins
- High luminous Intensity and high efficiency
- Compatible with reflow soldering process
- Low thermal resistance
- Long operation life
- Wide viewing angle at 120°
- Silicone encapsulation
- Environmental friendly, RoHS compliance

### APPLICATIONS

---

- Street lighting
- Par lighting
- Outdoor lighting

Note: The information in this document is subject to change without notice.

**PACKAGE DIMENSIONS**

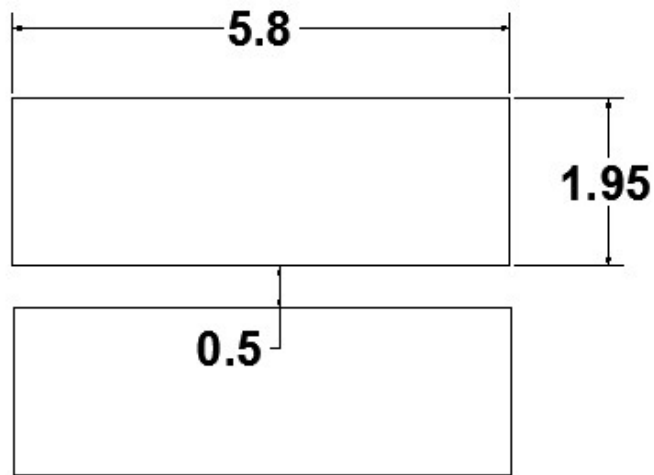
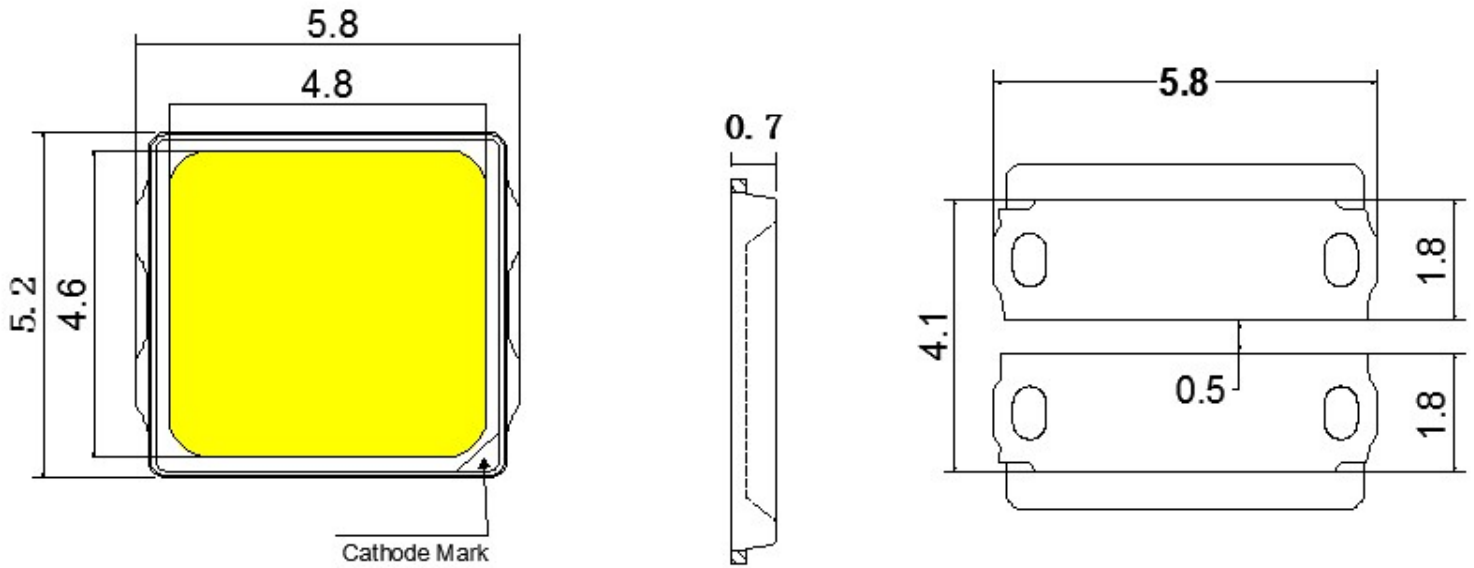

**Recommended PCB Soldering Pad Pattern**

Notes/ 注:

1. All dimensions in millimeters.
2. Thickness tolerance of copper plate is  $\pm 0.02$ mm.
3. Thickness tolerance of product is  $\pm 0.05$ mm.
4. Tolerance is  $\pm 0.1$ mm unless otherwise noted.

**ABSOLUTE MAXIMUM RATINGS ((T<sub>j</sub>=25°C; CRI70 ; CCT4000K)**

Parameter	Symbol	Value	Unit
Forward current	IF	250	mA
Peak Forward Current	IFP	300	mA
Reverse Voltage	VR	10	V
Operating Temperature	Topr	-40~+85	°C
Storage Temperature	Tstg	-40~+100	°C
Soldering Temperature	Tsld	Reflow Soldering: 260°C for 10 seconds	
LED Junction Temperature	Tj	125	°C

**ELECTRO-OPTICAL CHARACTERISTICS (T<sub>j</sub>=25°C)**

Parameter	Symbol	Forward Current	Min	Typ	Max	Unit
Forward Voltage	V <sub>F</sub>	IF=165mA	22	--	26	V
Viewing Angle	2θ <sub>1/2</sub>	IF=165mA	--	120	--	deg.
Luminous Flux	Φ <sub>v</sub>	IF=165mA	600	--	750	lm
Color Rendering Index	CRI	IF=165mA	70	--	--	--
Color Temperature	CCT	IF=165mA	2600	--	7000	K
Thermal Resistance	R <sub>th-js</sub>	IF=165mA	--	3	--	°C/W

Notes 注:

- Luminous flux is measured with an accuracy of  $\pm 5\%$ .
- Chromaticity coordinate bins are measured with an accuracy of  $\pm 0.01$ .
- CRI is measured with an accuracy of  $\pm 2$ .
- Some color and CRI bins may have limited availability, please contact us before ordering.
- All measurements were made under the standardized environment of Shineon

**ELECTRO-OPTICAL CHARACTERISTICS**  
 (T<sub>j</sub>=25°C; CRI70 ; 4000K)

Forward Current	Forward Voltage	Power	Luminous Flux	Luminous efficacy
	Typ	Typ	Typ	Typ
IF	VF	P	ΦV	η
40 mA	22.1 V	0.88 W	195 lm	222 lm/W
80 mA	23.0 V	1.84 W	378lm	207 lm/W
120 mA	23.9 V	2.86 W	550 lm	193 lm/W
160 mA	24.6 V	3.94 W	710 lm	181 lm/W
200 mA	25.3 V	5.07 W	860 lm	172 lm/W

Notes 注:

1. Luminous flux is measured with an accuracy of  $\pm 5\%$ .
2. Chromaticity coordinate bins are measured with an accuracy of  $\pm 0.01$ .
3. CRI is measured with an accuracy of  $\pm 2$ .
4. Some color and CRI bins may have limited availability, please contact us before ordering.
5. All measurements were made under the standardized environment of Shineon

**RELATIVE SPECTRAL POWER DISTRIBUTION ( $T_j=25^\circ\text{C}$ )**

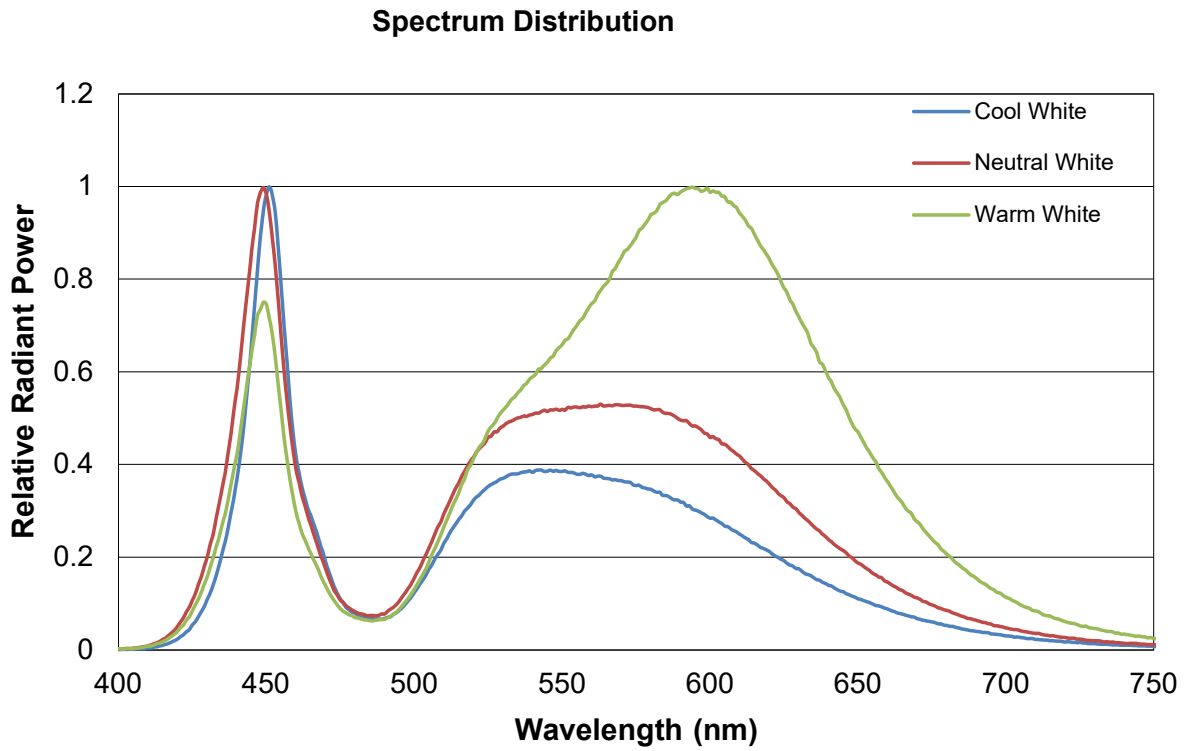

**TYPICAL SPATIAL DISTRIBUTION**

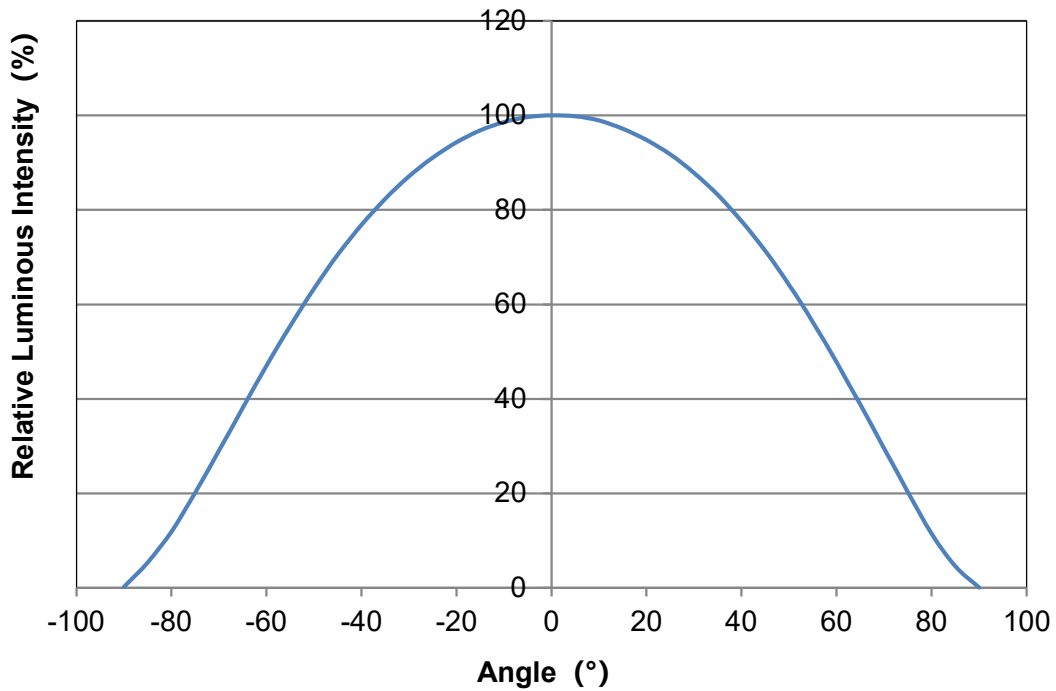

**RELATIVE LUMINOUS FLUX VS. CURRENT ( $T_j=25^\circ\text{C}$ )**

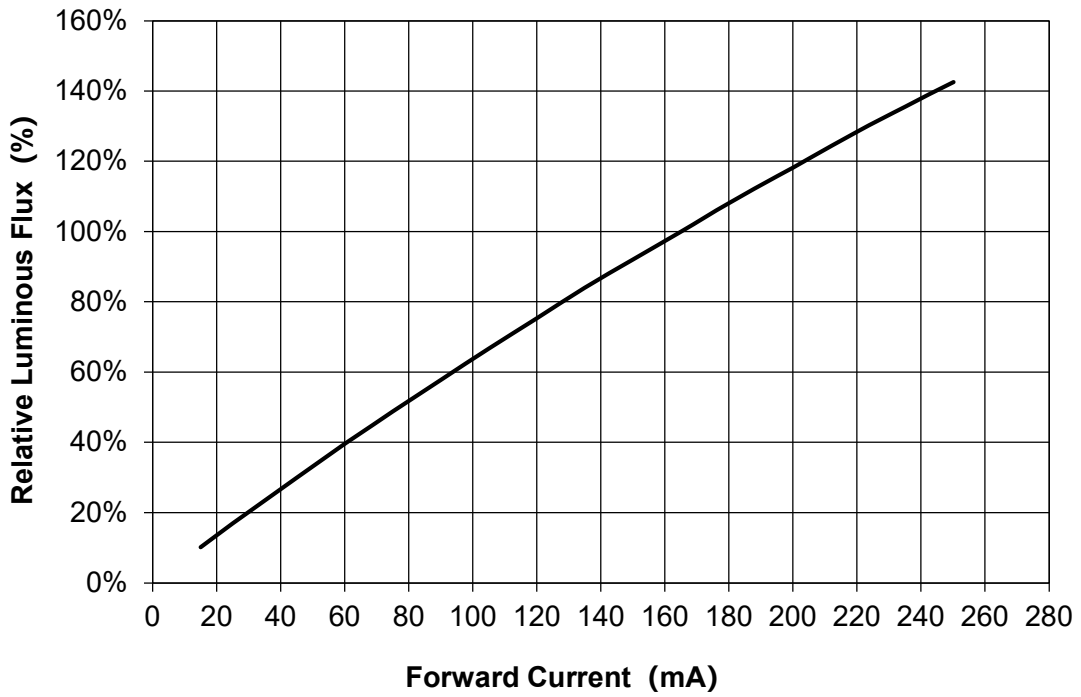

**ELECTRICAL CHARACTERISTICS ( $T_j=25^\circ\text{C}$ )**

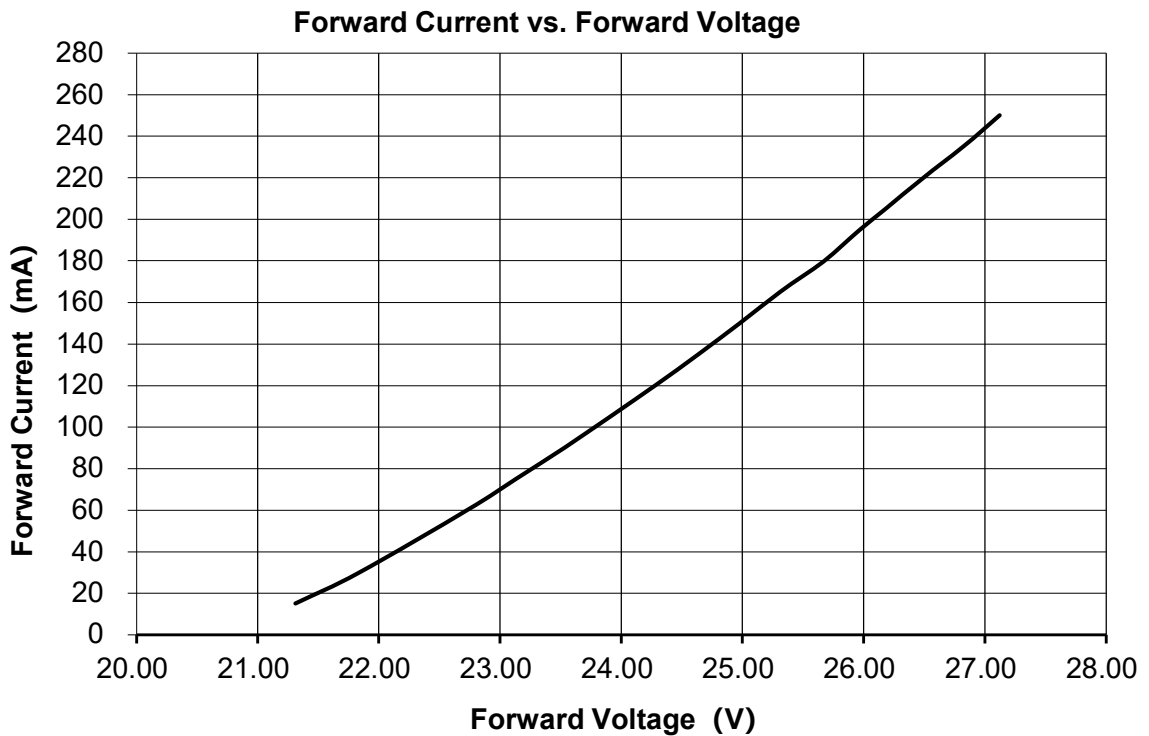

**MAXIMUM CURRENT VS. AMBIENT TEMPERATURE**

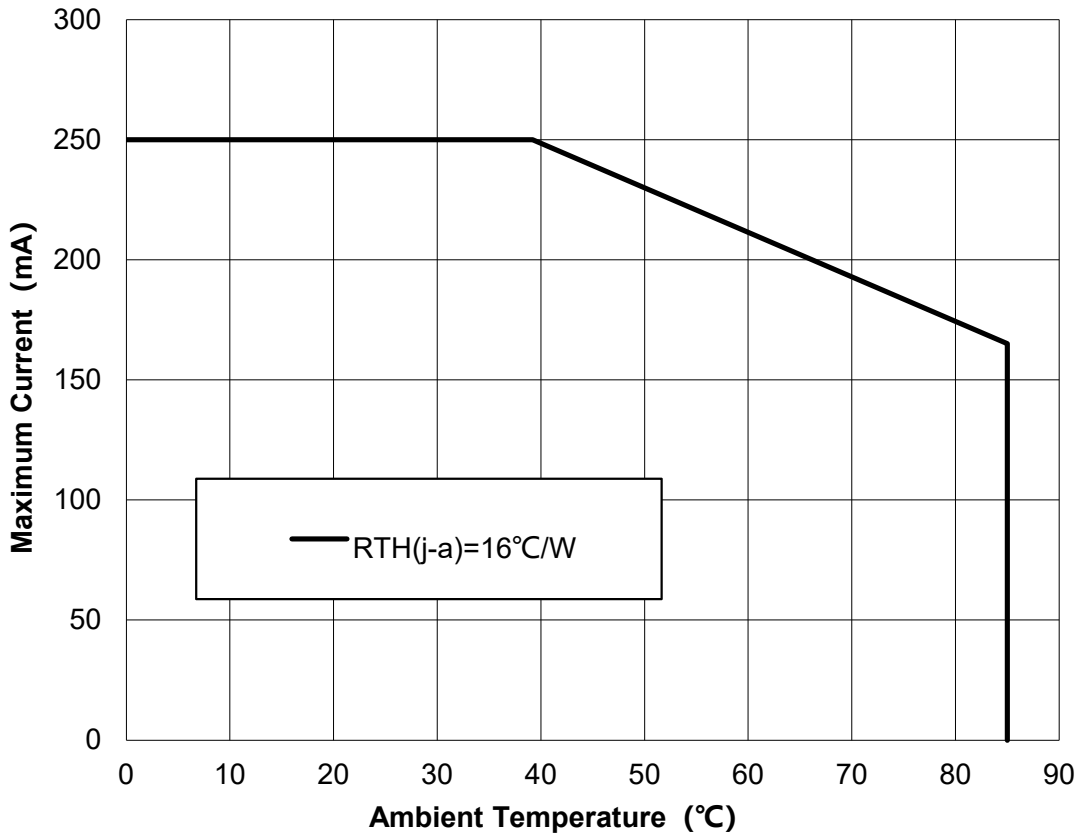

**RELATIVE RADIANT FLUX VS. JUNCTION TEMPERATURE**

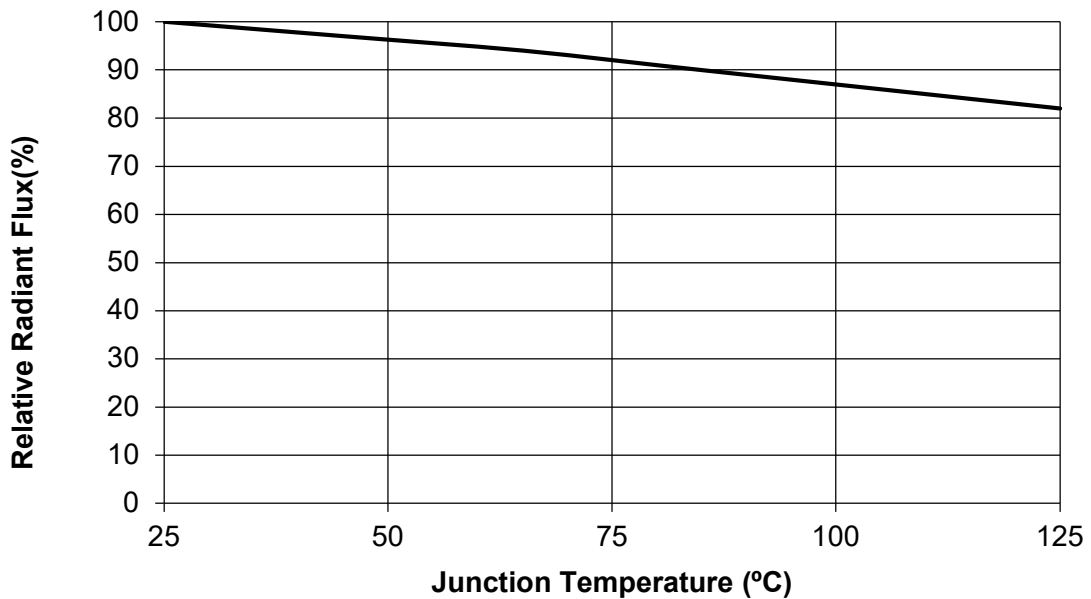



**SORTING RANKS**
**(1) Luminous Flux (Tj=25°C)**

Part Number	Condition	Rank	Unit
5050A24-27N165-U8S1P-V21-TD-LX	165mA	V0	lm
		600-650	
5050A24-30N165-U8S1P-V21-TD-LX		V3	
		650-700	
5050A24-40N165-U8S1P-V21-TD-LX		W0	
		700-750	
5050A24-50N165-U8S1P-V21-TD-LX		W0	
		700-750	
5050A24-57N165-U8S1P-V21-TD-LX		W0	
		700-750	
5050A24-65N165-U8S1P-V21-TD-LX	W0		
	700-750		

**(2) Forward Voltage (Tj=25°C)**

Rank	Condition	Min.	Max.	Unit
HB	165mA	22	24	V
HC		24	26	

Notes 注：

- 5% tolerance for luminous intensity may be caused by measurement inaccuracy.
- Measurement Uncertainty of the Forward Voltage :  $\pm 0.1$

(3) Chromaticity Bins

Part Number	5050A24-27N165-U8S1P-V21-TD-LX			CCT	2700K
Bin Code	Color Coordinates (x,y)				
A27-5	x	y	a	b	Theta°
	0.4578	0.4101	0.01290	0.00685	53.17

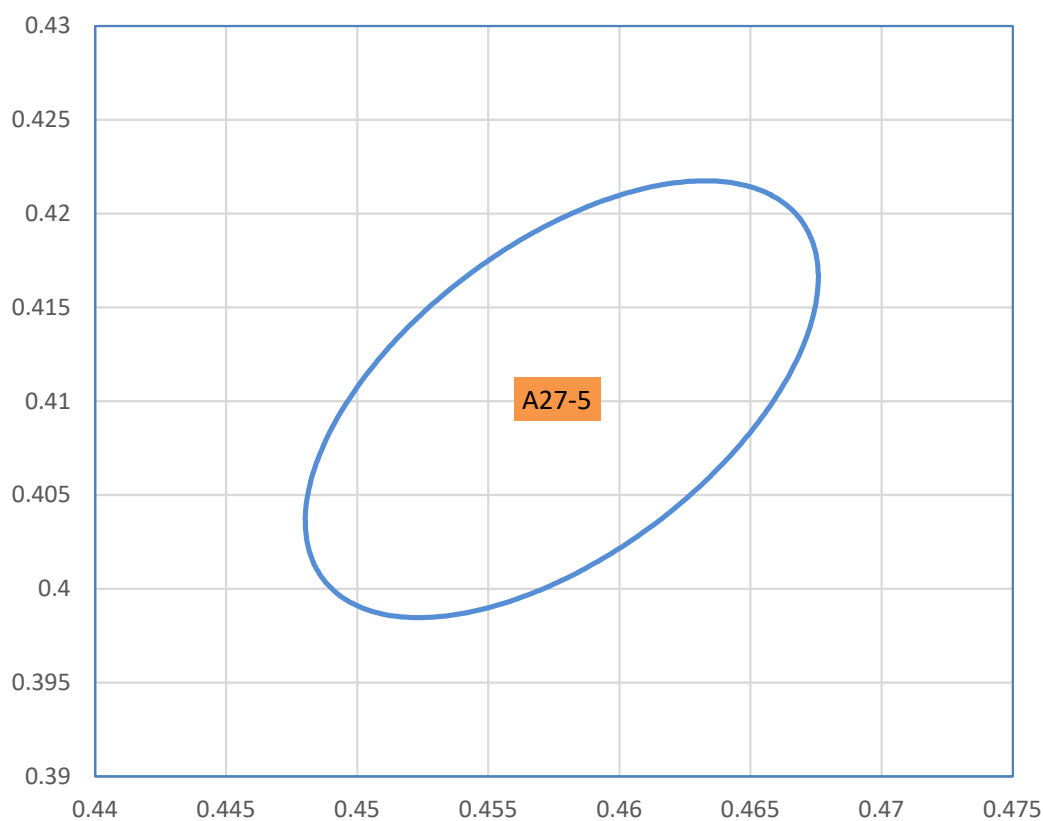

<b>Part Number</b>	<b>5050A24-30N165-U8S1P-V21-TD-LX</b>			<b>CCT</b>	<b>3000K</b>
<b>Bin Code</b>	<b>Color Coordinates (x,y)</b>				
<b>A30-5</b>	<b>x</b>	<b>y</b>	<b>a</b>	<b>b</b>	<b>Theta°</b>
	0.4338	0.403	0.01390	0.00680	53.2167

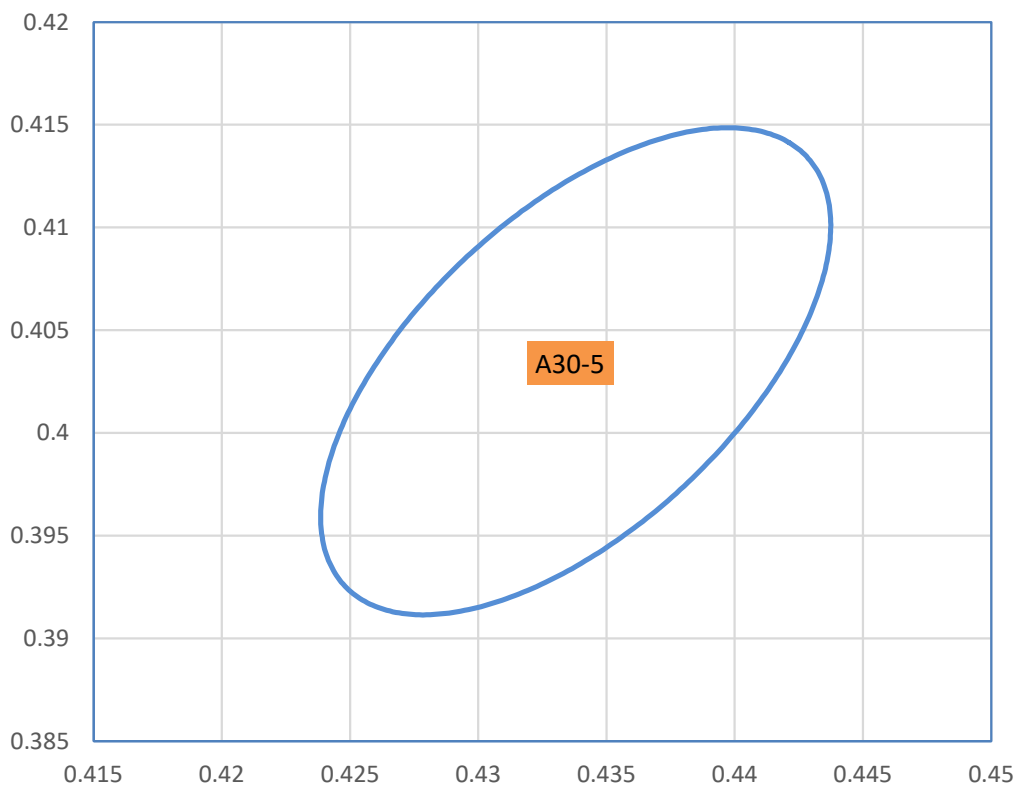

Part Number	5050A24-40N165-U8S1P-V21-TD-LX	CCT	4000K		
Bin Code	Color Coordinates (x,y)				
A40-5	x	y	a	b	Theta°
	0.3818	0.3797	0.01565	0.00670	53.717

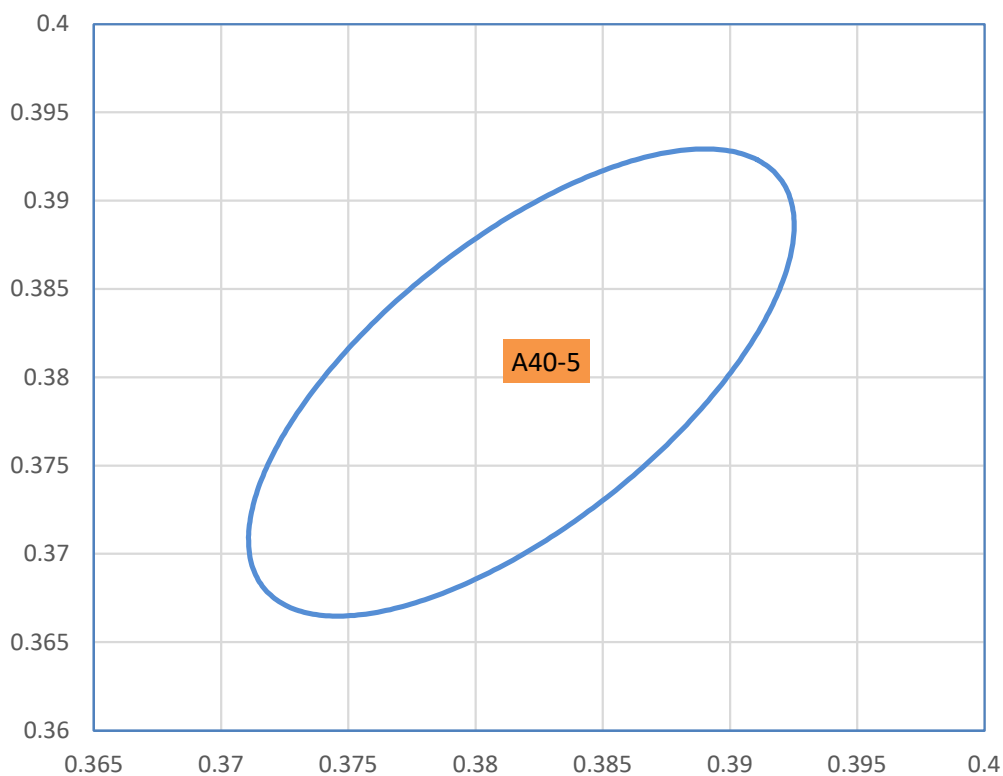

Part Number	5050A24-50N165-U8S1P-V21-TD-LX			CCT	5000K
Bin Code	Color Coordinates (x,y)				
A50-5	x	y	a	b	Theta°
	0.3447	0.3553	0.01370	0.00590	59.617

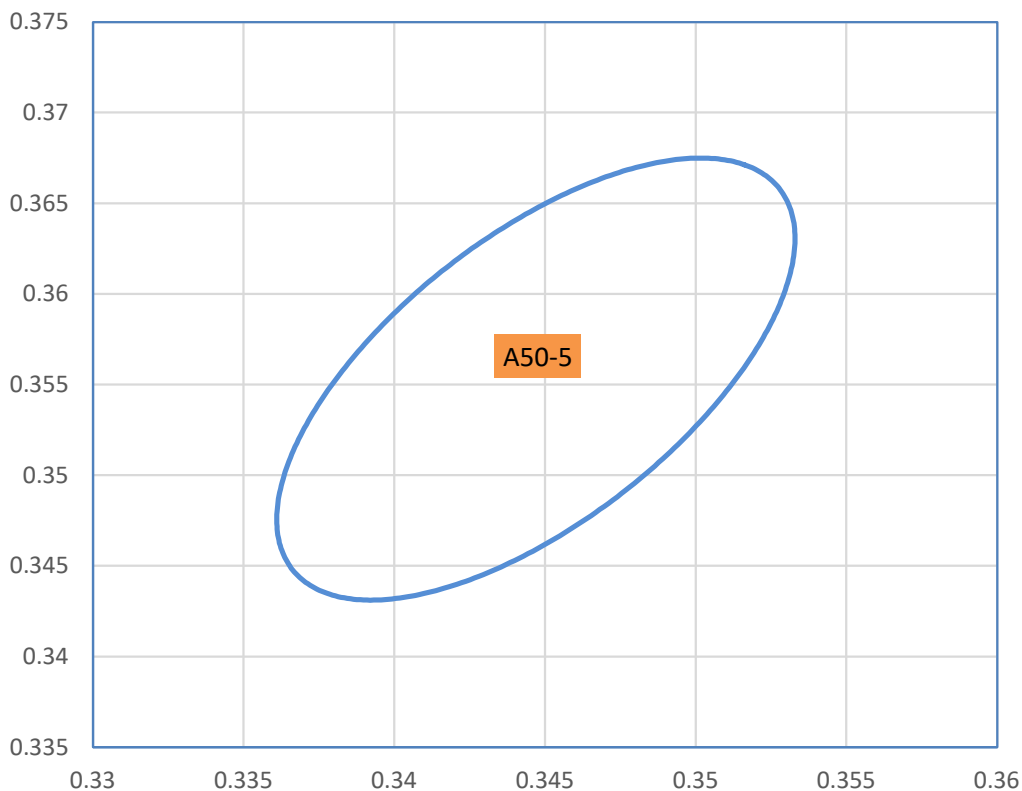

Part Number	5050A24-57N165-U8S1P-V21-TD-LX	CCT	5700K		
Bin Code	Color Coordinates 色坐标(x,y)				
A57-5	x	y	a	b	Theta°
	0.3287	0.3417	0.01245	0.00535	59.128

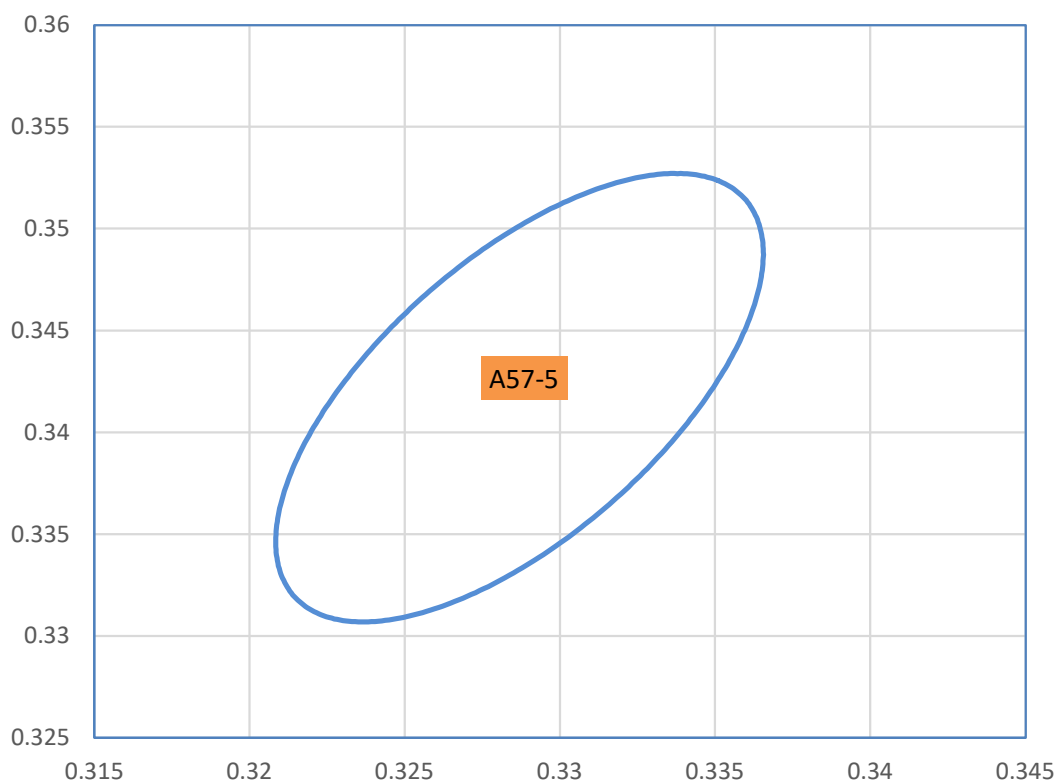

Part Number	5050A24-60N165-U8S1P-V21-TD-LX	CCT	6000K		
Bin Code	Color Coordinates (x,y)				
A60-5	x	y	a	b	Theta°
	0.322	0.3365	0.01179	0.00504	59.21

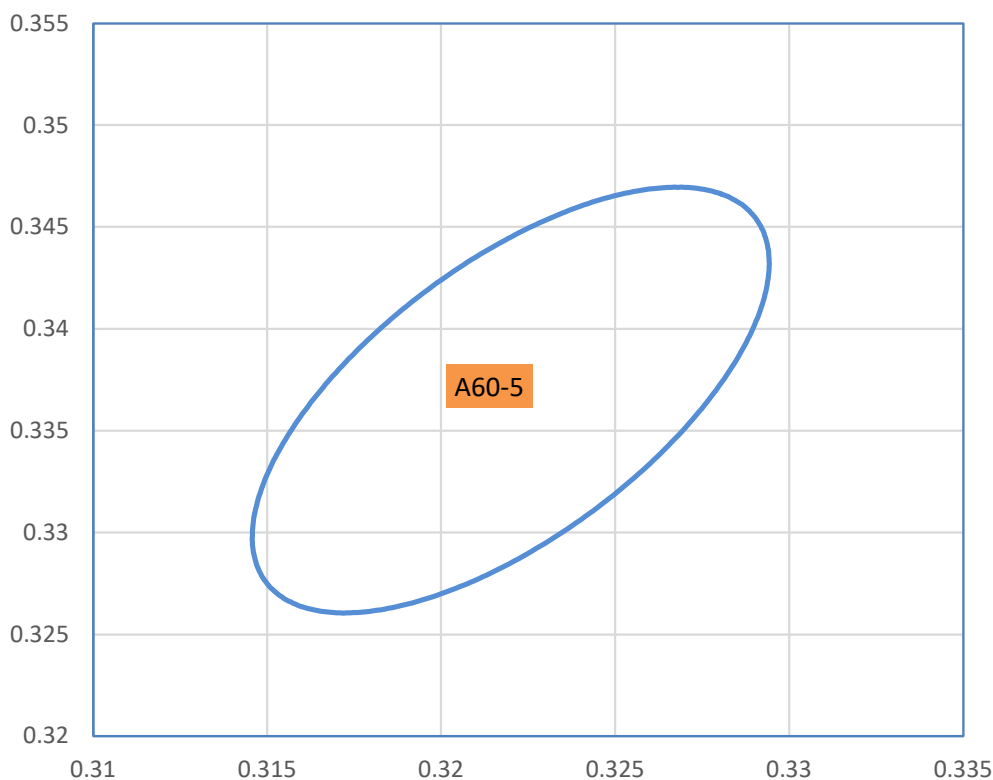

Part Number 品名	5050A24-65N165-U8S1P-V21-TD-LX			CCT 色温	6500K
Bin Code 等级代码	Color Coordinates 色坐标(x,y)				
A65-5	x	y	a	b	Theta°
	0.3123	0.3282	0.01115	0.00475	58.5667

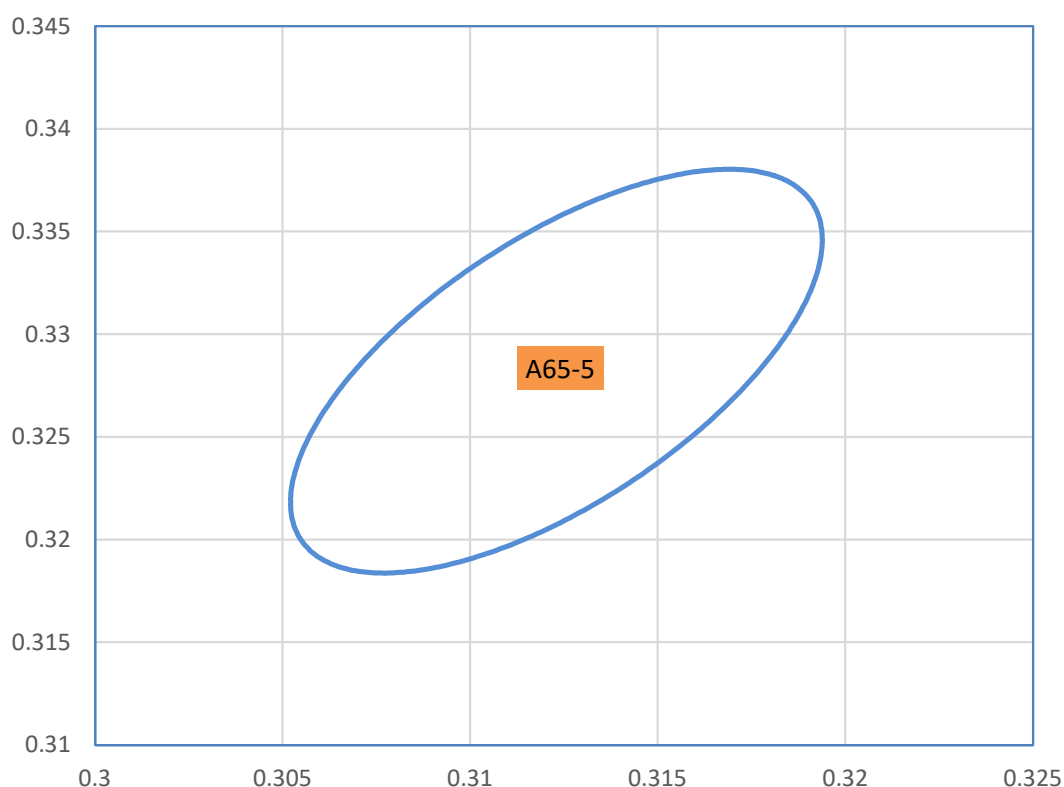



**TAPE AND REEL**

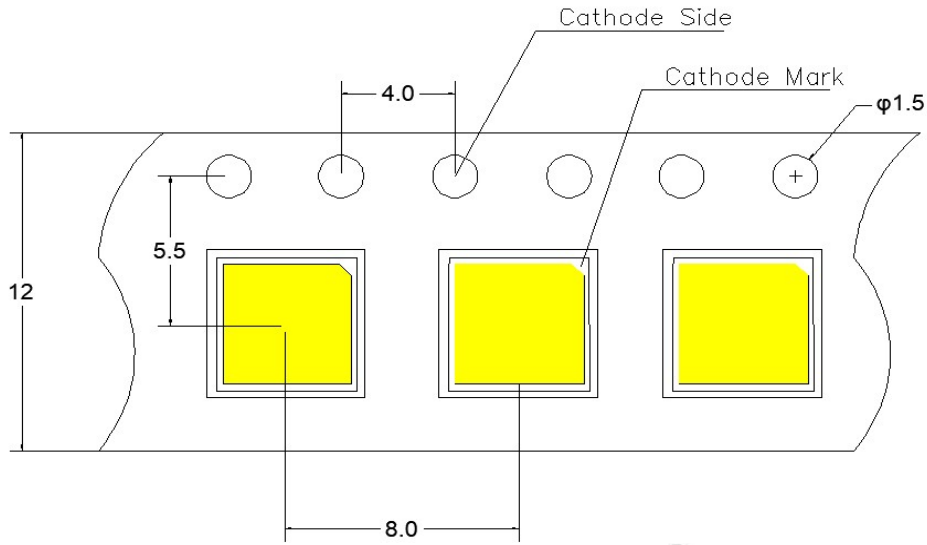

Small reel

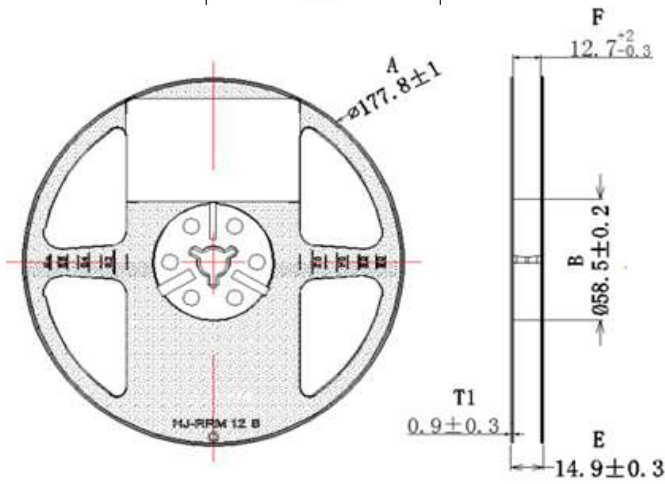

Big reel

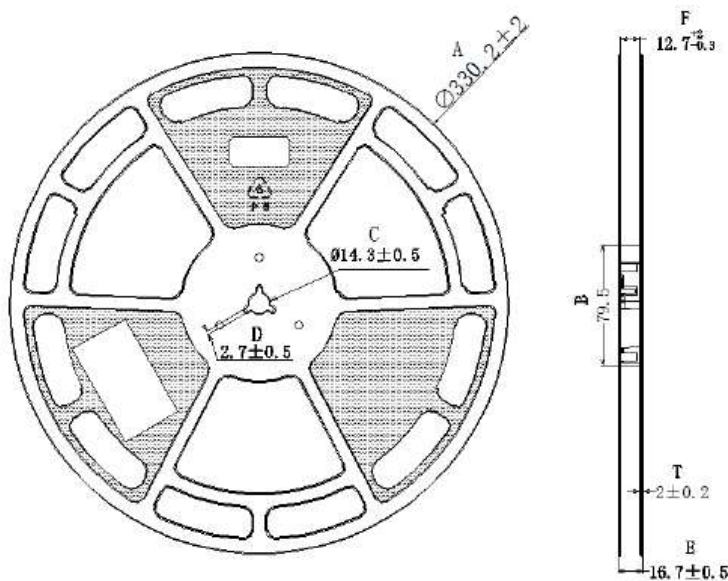

Notes:

- (1) Quantity : 1500pcs/Reel OR 5,000pcs/Reel
- (2) Cumulative Tolerance : Cumulative Tolerance/10 pitches to be  $\pm 0.2\text{mm}$
- (3) Adhesion Strength of Cover Tape : Adhesion strength to be 0.1-0.7N when the cover tape is turned off from the carrier tape at the angle of  $10^\circ$  to the carrier tape
- (4) Package : P/N, Manufacturing data Code No. and quantity to be indicated on a damp proof Package.

**PACKAGING**

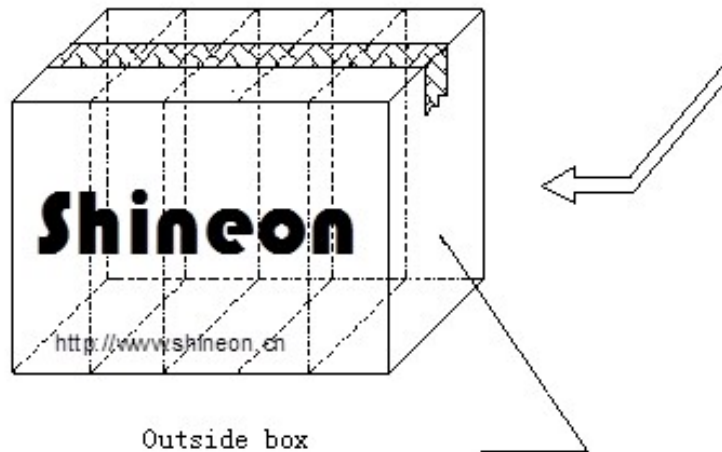
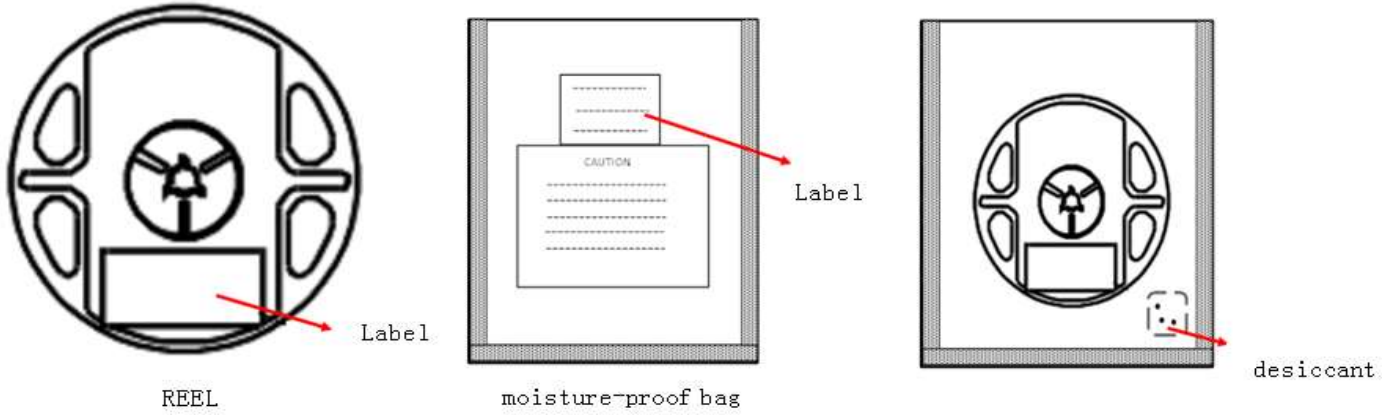

Notes:

- (1) Box size: 33x25x42cm 60K/Box 1500pcs/Reel
- (2) Box size: 38x36x42cm 80K/Box 5000pcs/Reel,

## REFLOW SOLDERING CHARACTERISTICS

### For Reflow Process :

Preheating 预热 : 140°C~160°C±5°C, within 2 minutes.

Operation heating 作业加热 : 260°C(Max.) within 10 seconds.(Max)

Gradual Cooling (Avoid quenching).

Lead solder		Lead-free solder	
Pre-heat	120-150°C	Pre-heat	150-200°C
Pre-heat time	120 sec.Max.	Pre-heat time	120 sec.Max.
Peak Temperature	240°C Max.	Peak Temperature	260°C Max.
Soldering time condition	10 sec.Max.	Soldering time condition	10 sec.Max.

 <p><b>Lead Solder</b></p> <p>2.5~5 °C / sec. (initial ramp)</p> <p>2.5~5 °C / sec. (second ramp)</p> <p>Pre-heating 120~150 °C (120sec. Max.)</p> <p>60sec. Max. Above 200 °C</p> <p>240 °C Max. (10 sec. Max.)</p>	 <p><b>Lead-free Solder</b></p> <p>1~5 °C / sec. (initial ramp)</p> <p>1~5 °C / sec. (second ramp)</p> <p>Pre-heating 150~200 °C (120sec. Max.)</p> <p>60sec. Max. Above 220 °C</p> <p>260 °C Max. (10 sec. Max.)</p>
--	---

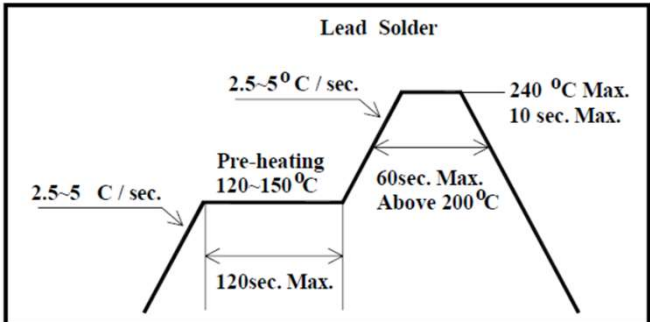
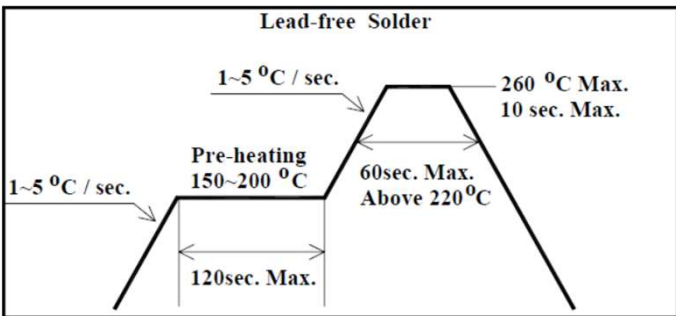
### Notes:

The encapsulated material of the LEDs is silicone . Therefore the LEDs have a soft surface on the top of package. The pressure to the top surface will be influence to the reliability of the LEDs. Precautions should be taken to avoid the strong pressure on the encapsulated part. So when using the picking up nozzle, the pressure on the silicone resin should be proper.

**Reliability Test Items**

Test Items	Test Duration	Number of Damaged
Steady State Operating Life of High Temperature (HTOL) $T_s=85^{\circ}\text{C}$ , $I_F=\text{Max}$	1000hrs	0/20
Steady State Operating Life of Low Temperature (LTOL) $T_a=-40^{\circ}\text{C}$ , $I_F=\text{Max}$	1000hrs	0/20
High Temperature Storage (HTS)	1000hrs	0/20
Low Temperature Storage (LTS)	1000hrs	0/20
Thermal Shock (TS) $-45^{\circ}\text{C}\sim 125^{\circ}\text{C}$ 15min dwell 30sec transfer	100cycles	0/20
Solder Resistance (SR) $265^{\circ}\text{C}$ , 3X MSL	5sec	0/20
Solder Ability (SA) $245^{\circ}\text{C}$ 5sec, 95% coverage	5sec	0/11

Item 项目	Symbol	Test Condition	Criteria for Judgment	
			Min.	Max.
Forward Voltage	$V_f$	$I_F=\text{Typical Current}$		U.S.L x1.1
Luminous Flux	$I_m$	$I_F=\text{Typical Current}$	L.S.L x0.7	
CCX&CCY	x,y	$I_F=\text{Typical Current}$		Shift<0.02

## PRECAUTION FOR USE

---

(1) This device should not be used in any type of fluid such as water, oil, organic solvent, etc. When washing is required, IPA should be used.

(2) When the LEDs are illuminating, operating current should be decided after considering the ambient maximum temperature.

(3) LEDs must be stored to maintain a clean atmosphere. If the LEDs are stored for 3 months or more after being shipped from ShineOn, a sealed container with a nitrogen atmosphere should be used for storage.

(4) The LEDs must be used within seven days after opening the moisture proof packing. Repack unused Products with anti-moisture packing, fold to close any opening and then store in a dry place.

(5) The appearance and specifications of the product may be modified for improvement without notice.

(6) This LED is sensitive to the static electricity and surge. It is recommended to use a wrist Band or anti-electrostatic glove when handling the LEDs.

(7) On manual soldering, a solder tip must be needed as grounded for usage. If over voltage which exceeds the absolute maximum rating is applied to LEDs, it will cause damage LEDs and result in destruction. Damaged LEDs will show some unusual characteristics such as leak current remarkably increase, turn-on voltage becomes lower and the LEDs get unlighted at low current.