

MODEL NO : TM040YDHG32**MODEL VERSION: 00****SPEC VERSION : 2.0****ISSUED DATE: 2018-10-25**

- Preliminary Specification
 Final Product Specification

Customer : _____

Approved by	Notes

TIANMA Confirmed :

Prepared by	Checked by	Approved by
Allen.Yin	Zhijie.Song	Xiaoxing.Ding

This technical specification is subjected to change without notice

Table of Contents

Table of Contents	2
Record of Revision	3
1 General Specifications	4
2 Input/Output Terminals	5
3 Absolute Maximum Ratings	6
4 Electrical Characteristics	7
5 Timing Chart.....	9
6 Optical Characteristics	14
7 Environmental / Reliability Test	17
8 Mechanical Drawing	19
9 Packing Drawing	20
10 Precautions for Use of LCD Modules	22

1 General Specifications

	Feature	Spec
Display Spec.	Size	3.97 inch
	Resolution	480(RGB) x 800
	Technology Type	a-Si TFT
	Pixel Configuration	R.G.B. Vertical Stripe
	Pixel pitch(mm)	0.108 x 0.108
	Display Mode	Normally Black
	Surface Treatment	LCD Up Polarizer: HC
	Viewing Direction	All Direction
Mechanical Characteristics	LCM (W x H x D) (mm)	56.34x95.70x1.83
	Active Area(mm)	51.84(W)x86.40(H)
	With /Without TSP	Without TSP
	Connection Type	FH35C-25S-0.3SHW
	LED Numbers	8LEDs
	Weight (g)	22.6
Electrical Characteristics	Interface	MIPI
	Color Depth	16M
	Driver IC	HX8369-A01

Note 1: Viewing direction for best image quality is different from TFT definition. There is a 180 degree shift.

Note 2: Requirements on Environmental Protection: Q/S0002

Note 3: LCM weight tolerance: $\pm 5\%$

2 Input/Output Terminals

Recommend connector type: FH35C-25S-0.3SHW

No	Symbol	I/O	Function	Remark
1	GND	P	Power Ground	
2	DSI_D1P	I/O	MIPI lane 1+	
3	DSI_D1N	I/O	MIPI lane 1-	
4	GND	P	Power Ground	
5	DSI_CP	I/O	MIPI clock +	
6	DSI_CN	I/O	MIPI clock -	
7	GND	P	Power Ground	
8	DSI_D0P	I/O	MIPI lane 0+	
9	DSI_D0N	I/O	MIPI lane 0-	
10	GND	P	Power Ground	
11	GND	P	Power Ground	
12	IOVDD	P	I/O Logic power (1.8V)	
13	GND	P	Power Ground	
14	VDD	P	Analog power 2.8V	
15	GND	P	Power Ground	
16	MIPI_MODE	I	command/vedio mode selection 0: command mode 1: vedio mode	
17	GND	P	Power Ground	
18	RST	I	RESET ACTIVE LOW	
19	GND	P	Power Ground	
20	TE	O	tearing effect output	
21	IC_ID	O	LCM ID Pin for customer identify IC_ID connect to IOVDD	
22	GND	P	Power Ground	
23	LEDA	P	LED anode	
24	LEDK	P	LED cathode	
25	GND	P	Power Ground	

Note1: I/O definition: I----Input O---Output P----Power/Ground

3 Absolute Maximum Ratings

Ta = 25°C

Item	Symbol	MIN	MAX	Unit	Remark
Logic Supply Voltage	IOVDD(LCD)	-0.3	3.6	V	Note1
Power Supply Voltage	VDD(LCD)	-0.3	5.5	V	
Logic Input voltage	I/O PINS(LCD)	-0.3	IOVDD+0.5	V	
Back Light Forward Current	I _{LED}		25	mA	One LED
Operating Temperature	T _{OPR}	-20	70	°C	
Storage Temperature	T _{STG}	-30	80	°C	
Relative Humidity Note2	RH	--	≤95	%	Ta ≤ 40°C
		--	≤85	%	40°C < Ta ≤ 50°C
		--	≤55	%	50°C < Ta ≤ 60°C
		--	≤36	%	60°C < Ta ≤ 70°C
		--	≤24	%	70°C < Ta ≤ 80°C
Absolute Humidity	AH	--	≤70	g/m ³	Ta > 70°C

Table 3 Absolute Maximum Ratings

Note1: Input voltage include DSI_D0P,DSI_D0N ,DSI_D1P,DSI_D1N , DSI_CP, DSI_CN, RST

Note2: Ta means the ambient temperature.

It is necessary to limit the relative humidity to the specified temperature range.
Condensation on the module is not allowed.

4 Electrical Characteristics

4.1 Driving TFT LCD

GND=0V, Ta=25°C

Item	Symbol	MIN	TYP	MAX	Unit	Remark	
Logic Supply Voltage	IOVDD	1.65	1.8/2.8	3.3	V		
Power Supply Voltage	VDD	2.3	2.8	3.3	V		
Input Signal Voltage	Low Level	V_{IL}	GND	--	$0.3 \cdot IOVDD$	V	
	High Level	V_{IH}	$0.7 \cdot IOVDD$	--	IOVDD	V	
Output Signal Voltage	Low Level	V_{OL}	0	--	$0.2 \cdot IOVDD$	V	
	High Level	V_{OH}	$0.8 \cdot IOVDD$	--	IOVDD	V	
(Panel+LSI) Power Consumption	White pattern Pvcc	--	60	90	mW	VCC=2.8V IOVCC=1.8V	
	White pattern Piovcc	--	0.3	0.45	mW	VCC=2.8V IOVCC=1.8V	

4.2 Driving Backlight

Ta=25°C

Item	Symbol	MIN	TYP	MAX	Unit	Remark
Forward Current	I_F	--	20	25	mA	
Forward Current Voltage	V_F	23.2	25.6	27.2	V	
Backlight Power Consumption	W_{BL}	--	512	--	mW	
Life Time	-	10,000	(20,000)		Hrs	

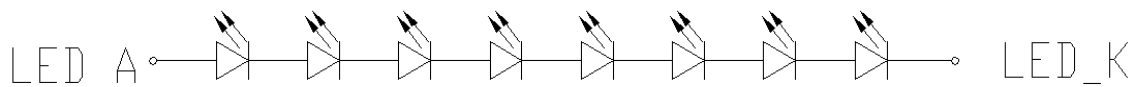
 Note 1: Each LED: $I_F=20\text{mA}$, $V=3.2\text{V}$.

LED connection of backlight

4.4 Block Diagram

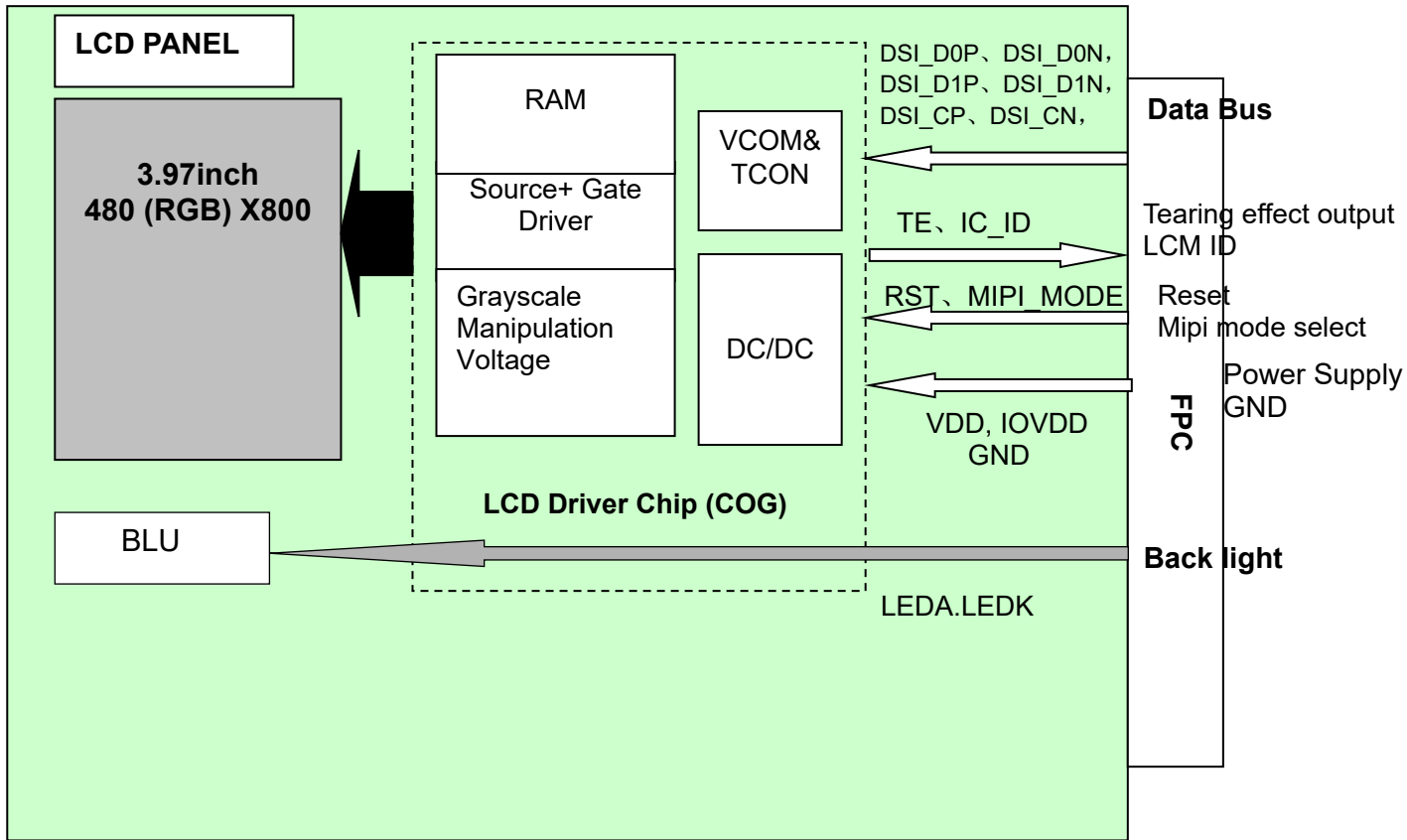

Figure 4.4.1 LCD module diagram

5 Timing Chart

5.1 MIPI Data to clock Timing Definition

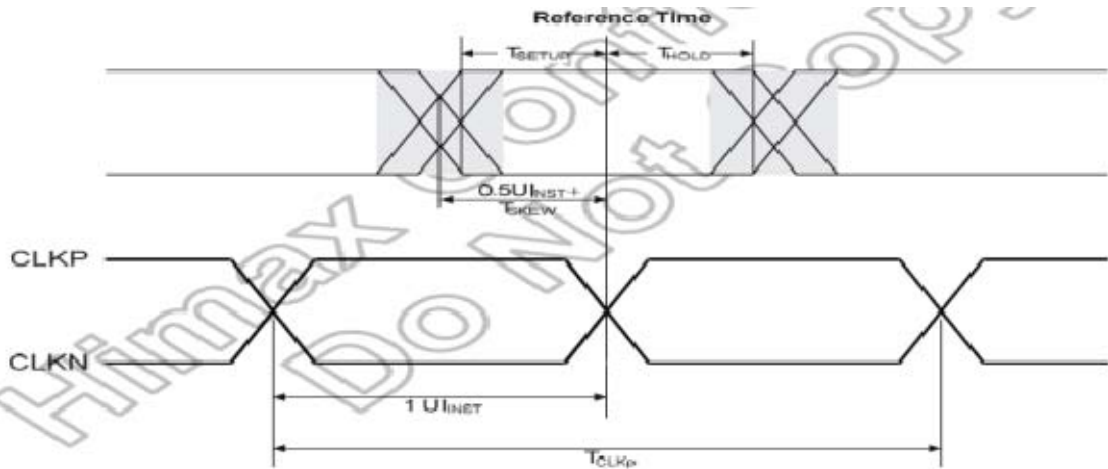

Figure 6.1.1 Data to clock Timing Definition

Parameter	Symbol	Min	Typ	Max	Unit	Note
Data to Clock Setup Time [receiver]	$T_{SETUP(RX)}$	0.15			UIINST	1
Clock to Data Hold Time [receiver]	$T_{HOLD(RX)}$	0.15			UIINST	1

Table 5.1.1 Data to Clock Timing Specifications

5.2 The Electrical Characteristics of HS and LP

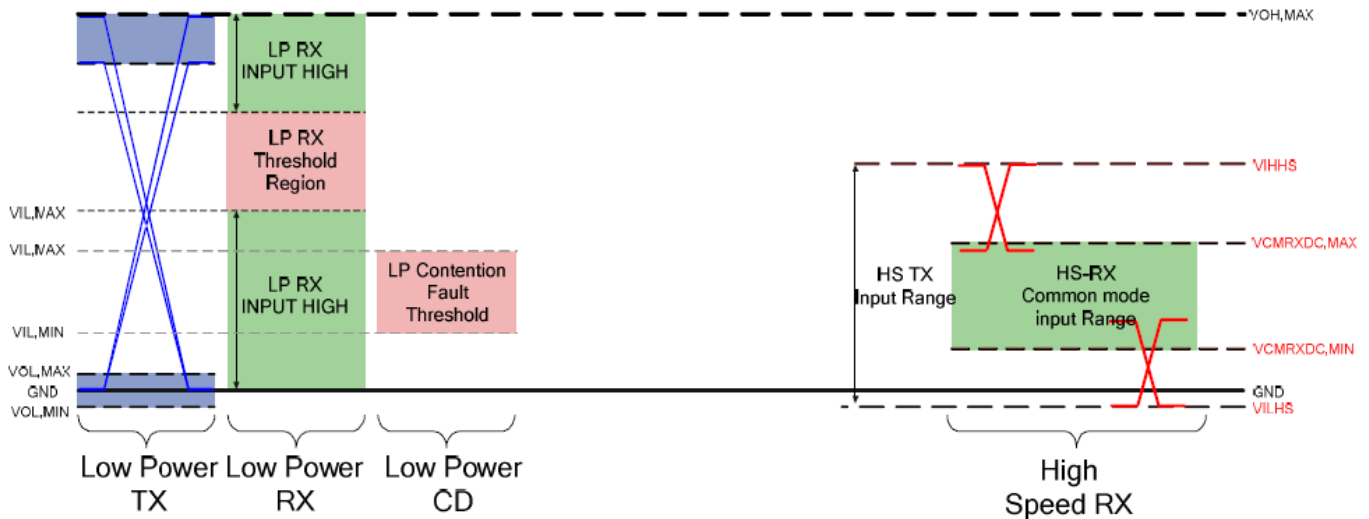

Figure 6.2.1 Shows both the HS and LP signal levels

Parameter	Description	Min	Nom	Max	Units	Note
V_{OL}	Thevenin output low level	-50		50	mV	
V_{OH}	Thevenin output high level	1.1	1.2	1.3	V	
Z_{OLP}	Output impedance of LP-TX	110			Ω	1

Table 5.2.1 LP Transmitter DC Specifications

Parameter	Description	Min	Nom	Max	Units	Note
$t_{RLP/IFLP}$	15%-85% rise time and fall time	-	-	25	ns	1
$\delta V/\delta t_{SR}$	Slew rate @ CLOAD = 0pF	-	-	500	mV/ns	1, 3, 5, 6
	Slew rate @ CLOAD = 5pF	-	-	300	mV/ns	1, 3, 5, 6
	Slew rate @ CLOAD = 20pF	-	-	250	mV/ns	1, 3, 5, 6
	Slew rate @ CLOAD = 70pF	-	-	150	mV/ns	1, 3, 5, 6
	Slew rate @ CLOAD = 0 to 70pF (Falling Edge Only)	30	-	-	mV/ns	1, 2, 3
C_{LOAD}	Slew rate @ CLOAD = 0 to 70pF (Rising Edge Only)	30	-	-	mV/ns	1, 3, 7
	Slew rate @ CLOAD = 0 to 70pF (Rising Edge Only)	30 - 0.075 * (VO_INST - 700)	-	-	mV/ns	1, 8, 9
C_{LOAD}	Load capacitance	-	-	70	pF	

Table 5.2.2 LP Transmitter AC Specifications

5.3 High-Speed Receiver

Parameter	Description	Min	Nom	Max	Units	Note
V_{IDTH}	Differential input high threshold			70	mV	
V_{IDTL}	Differential input low threshold	-70			mV	
V_{ILHS}	Single-ended input low voltage	-40			mV	1
V_{IHHS}	Single-ended input high voltage			460	mV	1
V_{CMRXDC}	Common-mode voltage HS receive mode	70		330	mV	1, 2
Z_{ID}	Differential input impedance	80	100	125	Ω	

Table 5.3.1 HS Receiver DC Specifications

Parameter	Description	Min	Nom	Max	Units	Note
$\Delta V_{CMRX(HF)}$	Common mode interference beyond 450 MHz			100	mV _{PP}	1
C_{CM}	Common mode termination			60	pF	2

Table 5.3.2 HS Receiver AC Specifications

5.4 Low-Power Receiver

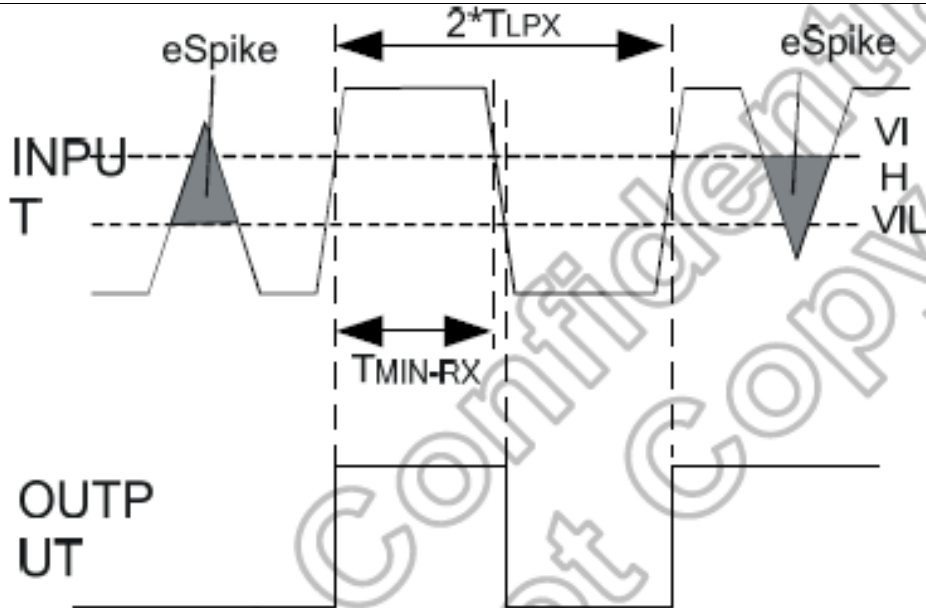

Figure 5.4.1 Input Glitch Rejections of Low-Power Receivers

Parameter	Description	Min	Nom	Max	Units	Note
V _{IL}	Logic 0 input threshold			550	mV	
V _{IH}	Logic 1 input threshold	880			mV	

Table 5.4.1 LP Receiver DC Specifications

Parameter	Description	Min	Nom	Max	Units	Note
θ _{SPIKE}	Input pulse rejection			300	V.ps	1, 2, 3
T _{MIN}	Minimum pulse width response	20			ns	4
V _{INT}	Peak-to-peak interference voltage			200	mV	
f _{INT}	Interference frequency	450			MHz	

Table 5.4.2 LP Receiver AC Specifications

5.5 Reset Timing Characteristics(Ta=25°C)

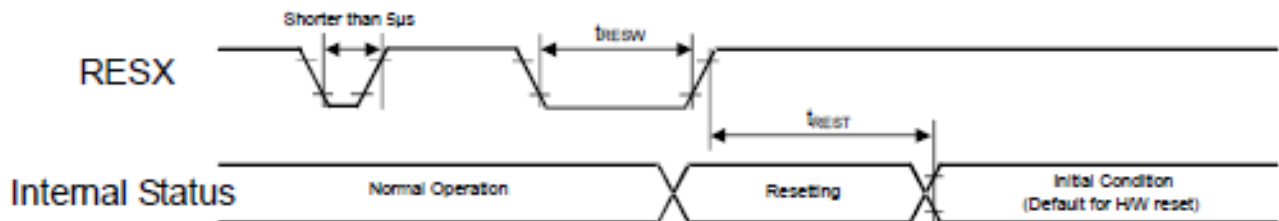
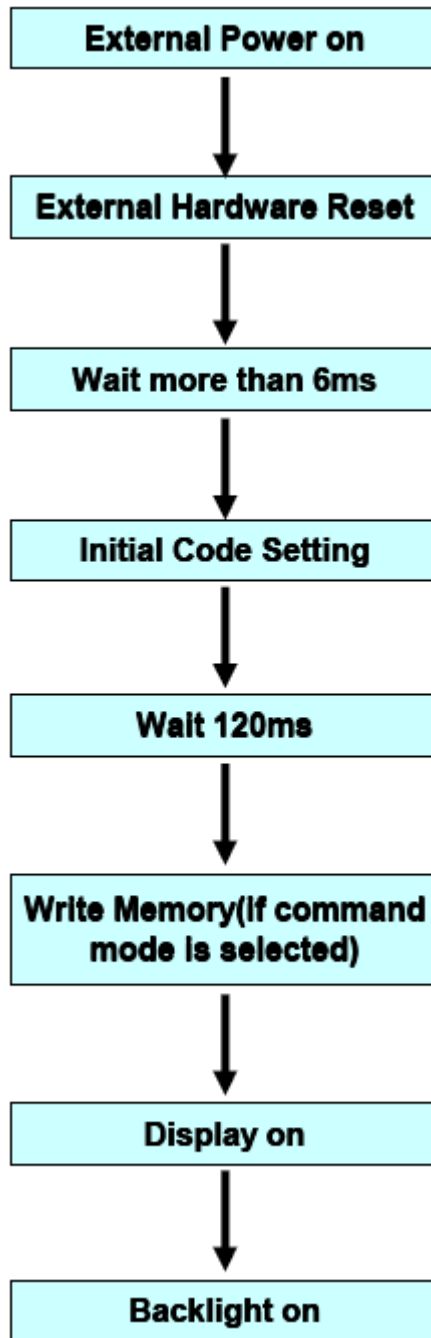

Figure 5.5.1 Reset input timing

Symbol	Parameter	Related pins	Min.	Typ.	Max.	Note	Unit
t _{RESW}	Reset low pulse width ⁽¹⁾	RESX	10	-	-	-	μs
t _{REST}	Reset complete time ⁽²⁾	-	5	-	-	When reset is applied during Sleep In mode	ms
		-	120	-	-	When reset is applied during Sleep Out mode	ms

Table 5.5.1 Reset input timing SPEC

5.6 Power On Sequence



TIANMA

CONFIDENTIAL

5.7 Power off Sequence

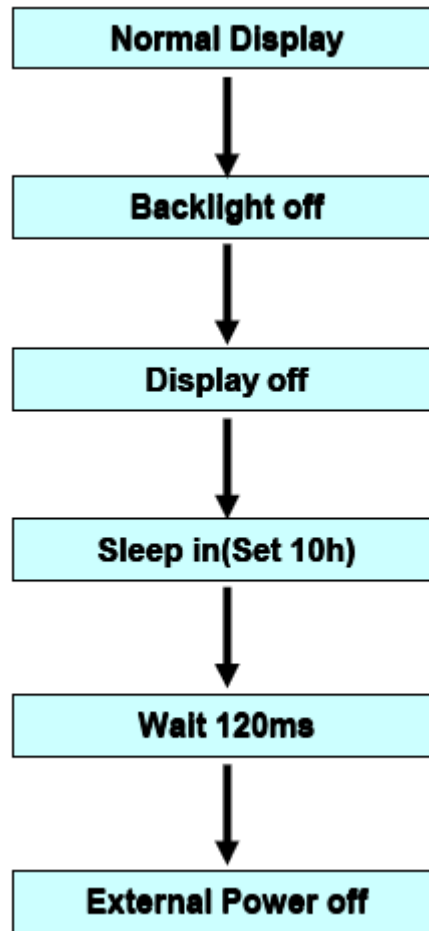

6 T-LCM Optical Characteristics

Item	Symbol	Condition	Min	Typ	Max	Unit	Remark
View Angles	θT	$CR \geq 10$	70	80		Degree	Note2,3
	θB		70	80			
	θL		70	80			
	θR		70	80			
Contrast Ratio	CR	$\theta=0^\circ$	600	800			Note 3
Response Time	T_{ON}	25°C		25	35	ms	Note 4
	T_{OFF}						
Chromaticity	White	Backlight is on	x	0.273	0.313	0.353	Note 1,5
			y	0.289	0.329	0.369	
	Red		x	0.594	0.634	0.674	Note 1,5
			y	0.289	0.329	0.369	
	Green		x	0.283	0.323	0.363	Note 1,5
			y	0.576	0.616	0.656	
	Blue		x	0.112	0.152	0.192	Note 1,5
			y	0.023	0.063	0.103	
Uniformity	U		80	85		%	Note 6
NTSC			62	67		%	Note 5
Luminance	L		500	550		cd/m ²	Note 7

Test Conditions:

1. $I_F=20\text{ mA}$, and the ambient temperature is 25°C.
2. The test systems refer to Note 1 and Note 2.

Note 1: Definition of optical measurement system.

The optical characteristics should be measured in dark room. After 5 Minutes operation, the optical properties are measured at the center point of the LCD screen. All input terminals LCD panel must be ground when measuring the center area of the panel.

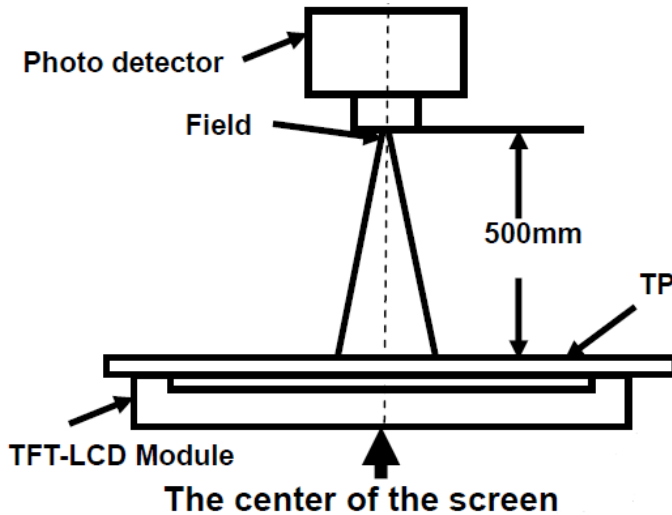

Note 2: Definition of viewing angle range and measurement system.

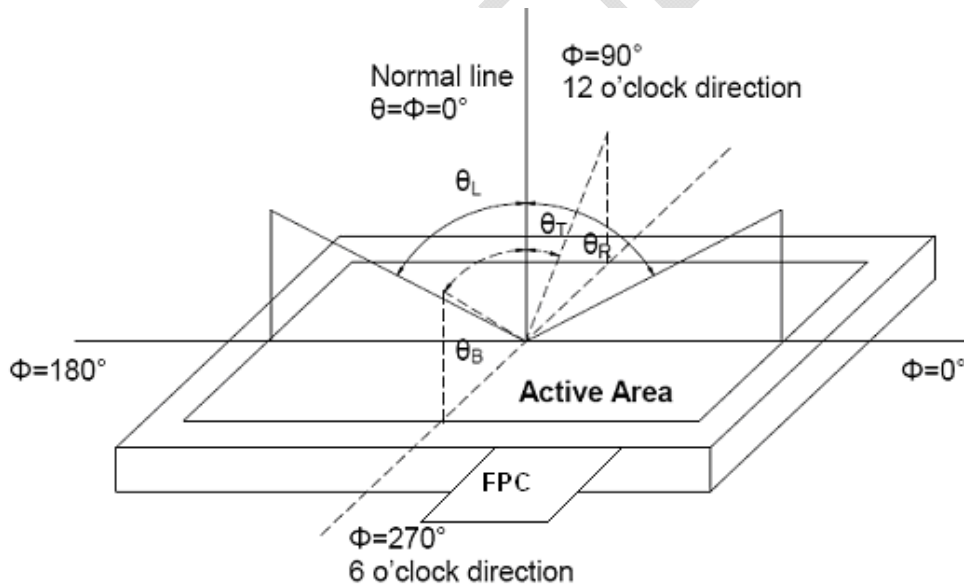

Note 3: Definition of contrast ratio

$$\text{Contrast ratio (CR)} = \frac{\text{Luminance measured when LCD is on the "White" state}}{\text{Luminance measured when LCD is on the "Black" state}}$$

“White state “: The state is that the LCD should drive by V_{white} .

“Black state”: The state is that the LCD should drive by V_{black} .

V_{white} : To be determined V_{black} : To be determined.

Note 4: Definition of Response time

The response time is defined as the LCD optical switching time interval between “White” state and “Black” state. Rise time (T_{ON}) is the time between photo detector output intensity changed from 90% to 10%. And fall time (T_{OFF}) is the time between photo detector output intensity changed from 10% to 90%.

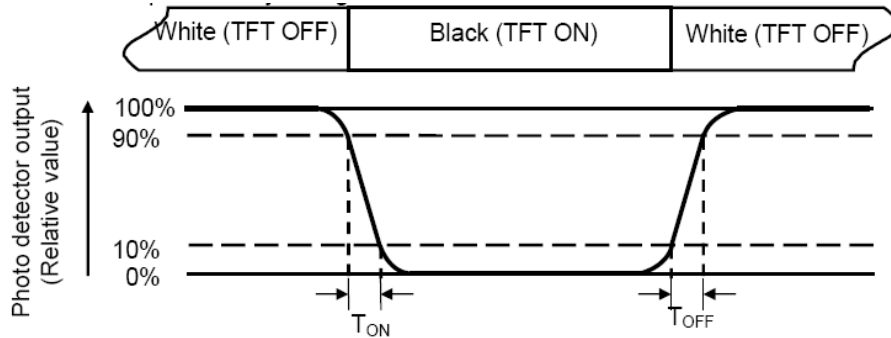

Note 5: Definition of color chromaticity (CIE1931)

Color coordinates measured at center point of LCD.

Note 6: Definition of Luminance Uniformity

Active area is divided into 9 measuring areas (Refer Fig. 2). Every measuring point is placed at the center of each measuring area.

$$\text{Luminance Uniformity (U)} = L_{\min} / L_{\max}$$

L-----Active area length W----- Active area width

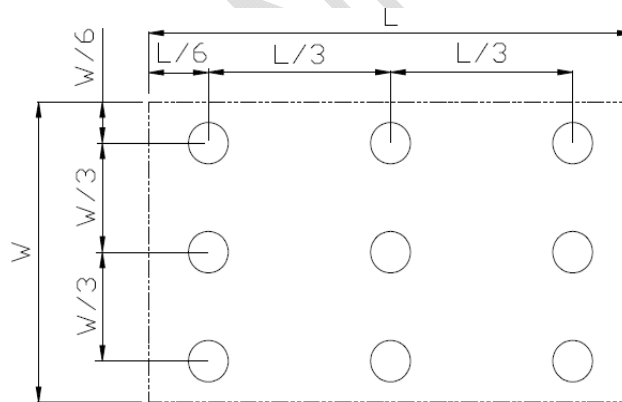

L_{\max} : The measured Maximum luminance of all measurement position.

L_{\min} : The measured Minimum luminance of all measurement position.

Note 7: Definition of Luminance:

Measure the luminance of white state at center point.

7 Environmental / Reliability Test

No	Test Item	Condition	Remarks
1	High Temperature Operation	Ts = +70℃, 240 hours	IEC60068-2-1:2007 GB2423.2-2008
2	Low Temperature Operation	Ta = -20℃, 240 hours	IEC60068-2-1:2007 GB2423.1-2008
3	High Temperature Storage	Ta = +80℃, 240 hours	IEC60068-2-1:2007 GB2423.2-2008
4	Low Temperature Storage	Ta = -30℃, 240 hours	IEC60068-2-1:2007 GB2423.1-2008
5	Storage at High Temperature and Humidity	Ta = +60℃, 90% RH max,240hours	IEC60068-2-78 :2001 GB/T2423.3—2006
6	Thermal Shock (non-operation)	-30℃ 30 min~+80℃ 30 min, Change time:5min, 100 Cycle	Start with cold temperature, End with high temperature, IEC60068-2-14:1984,G B2423.22-2002
7	ESD	C=150pF , R=330Ω , 5point/panel Air : ±8kv , 5times ; Contact : ±4kv , 5times ; (Environment : 15℃~35℃ , 30%~60% , 86Kpa~106Kpa)	ul 991-2008 Section 15
8	Vibration Test	Frequency range:10~55Hz Stroke:1.5mm Sweep:10Hz~55Hz~10Hz 2 hours for each direction of X.Y.Z. (6 hours for total)	IEC60068-2-6:1982 GB/T2423.10—1995
9	Mechanical Shock (Non Op)	Half Sine Wave 100G 6ms, ±X,±Y,±Z 3times for each direction	IEC60068-2-27:1987 GB/T2423.5—1995
10	Package Drop Test	Height:60cm, 1corner,3edges,6surfaces	IEC60068-2-32:1990 GB/T2423.8—1995

Note1: Ta is the ambient temperature of sample.

Note2: Before cosmetic and function test, the product must have enough recovery time, at least 2 hours at room temperature.

Note 3: In the standard condition, there shall be no practical problem that may affect the display function. After the reliability test, the product only guarantees operation, but don't guarantee all of the cosmetic specification.

TIANMA CONFIDENTIAL

8. Mechanical Drawing

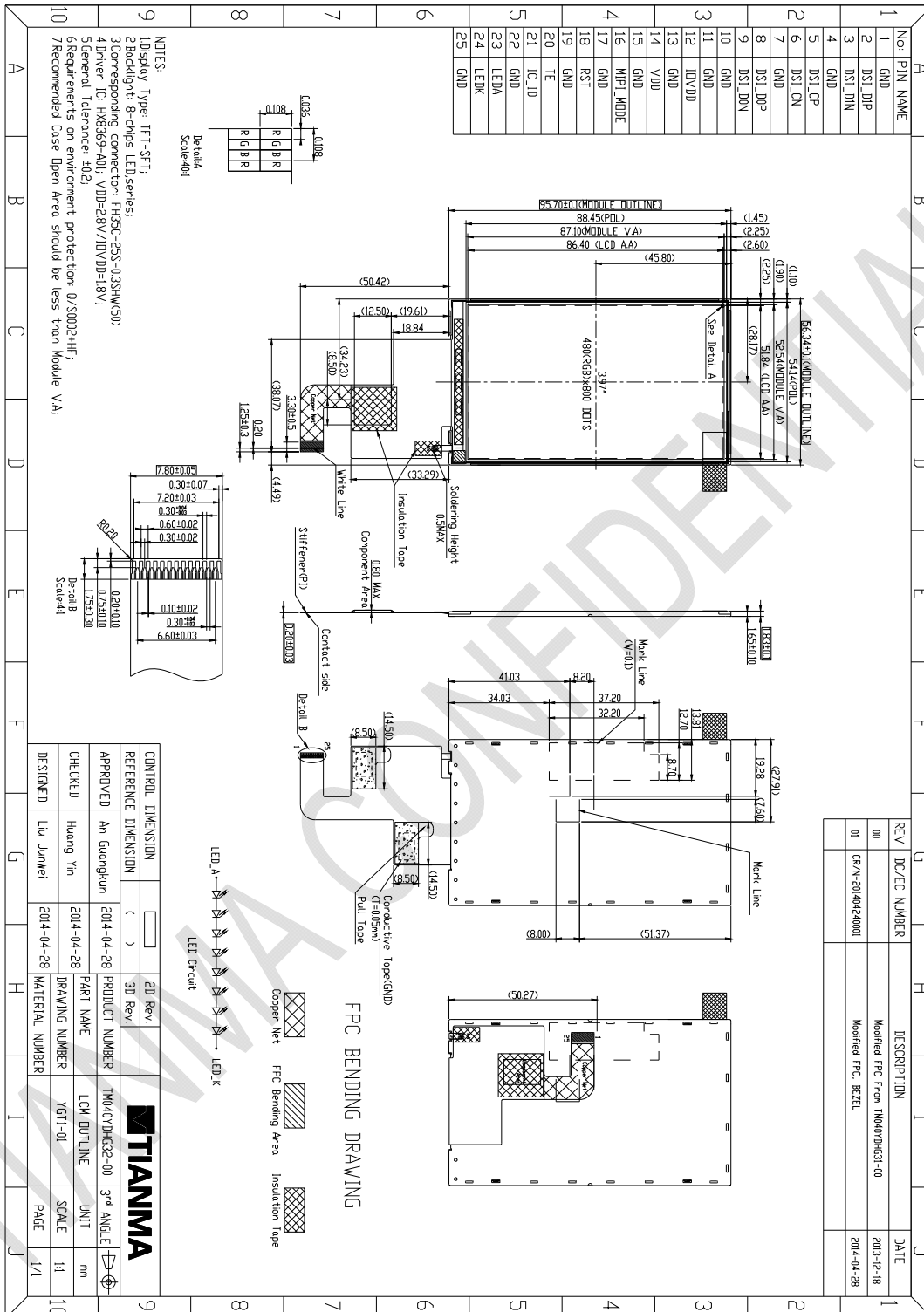

9 Packing Drawing

No. (序号)	Item (项目)	Model(Material) (材料型号)	Dimensions(mm) (规格)	Unit Weight(Kg) (单个重量)	Quantity (数量)	Remark (备注)
1	LCM module (模组型号)	TM040YHDG32	56.34x95.70x1.83mm	0.0226	108	
2	Tray (吸塑盘)	TM040YVZG31 YBZ1-00	251×351×13.1	0.161	30	Anti-static
3	EPE (珍珠棉1)	MBZ-ZZML1	336×246×6mm	0.01	6	
4	EPE (珍珠棉2)	MBZ-ZZM15	375×275×10mm	0.014	4	
5	EPE (珍珠棉3)	MBZ-ZZM16	250×280×12mm	0.015	2	
6	Carton (纸箱)	X18A	395×290×315mm	0.76	1	
7	ES bag (防静电 真空包装袋)	JD13	400×520	0.042	3	
8	Total weight (总 重量)	1.025 Kg				

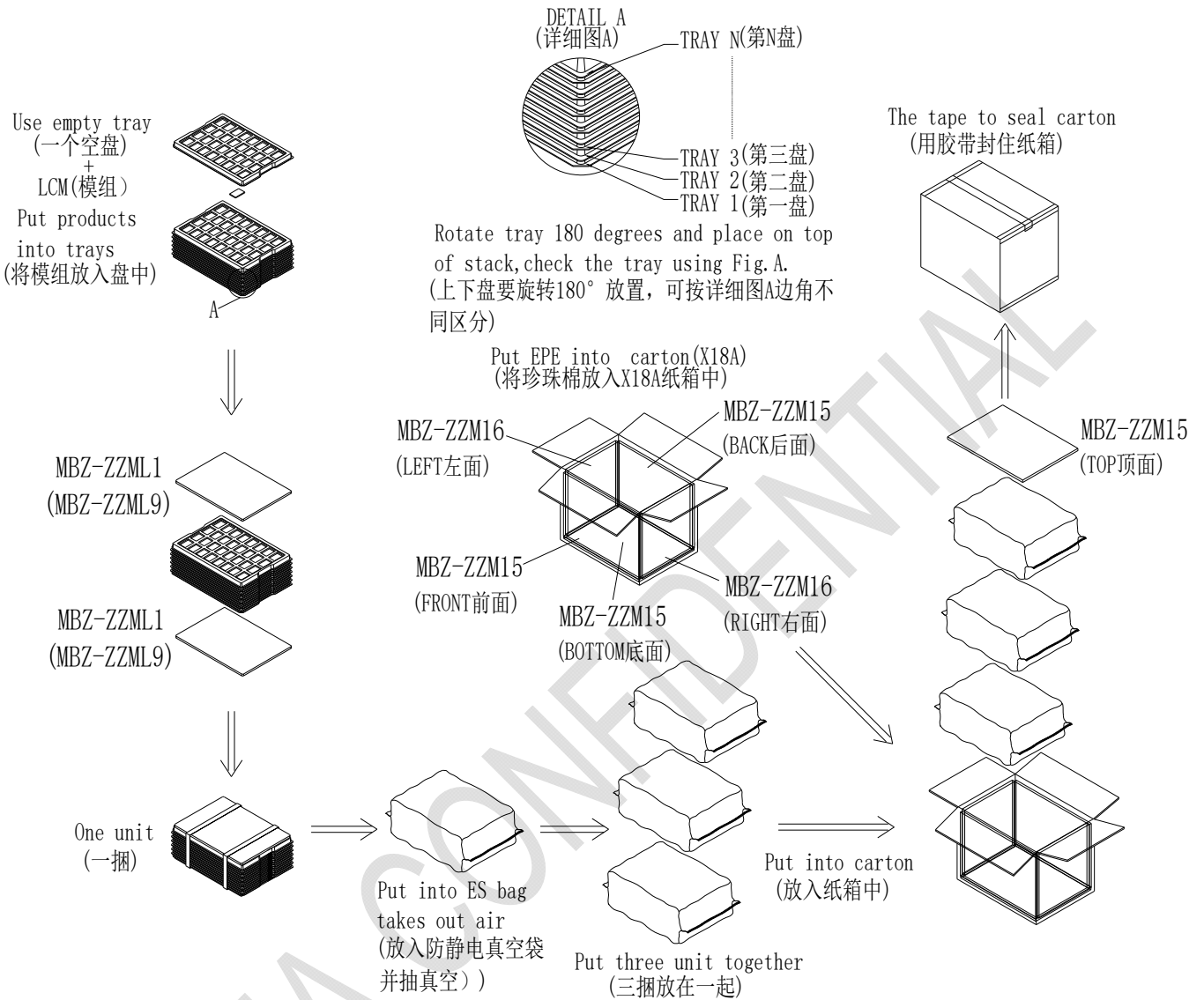

10 Precautions for Use of LCD Modules

a. Handling Precautions

- i. The display panel is made of glass. Do not subject it to a mechanical shock by dropping it from a high place, etc.
- ii. If the display panel is damaged and the liquid crystal substance inside it leaks out, be sure not to get any in your mouth, if the substance comes into contact with your skin or clothes, promptly wash it off using soap and water.
- iii. Do not apply excessive force to the display surface or the adjoining areas since this may cause the color tone to vary.
- iv. The polarizer covering the display surface of the LCD module is soft and easily scratched. Handle this polarizer carefully.
- v. If the display surface is contaminated, breathe on the surface and gently wipe it with a soft dry cloth. If still not completely clear, moisten cloth with one of the following solvents:
 - Isopropyl alcohol
 - Ethyl alcohol

Solvents other than those mentioned above may damage the polarizer. Especially, do not use the following:

- Water
 - Ketone
 - Aromatic solvents
- vi. Do not attempt to disassemble the LCD Module.
 - vii. If the logic circuit power is off, do not apply the input signals.
 - viii. To prevent destruction of the elements by static electricity, be careful to maintain an optimum work environment.
 - 10.1.8.1 Be sure to ground the body when handling the LCD Modules.
 - 10.1.8.2 Tools required for assembly, such as soldering irons, must be properly ground.
 - 10.1.8.3 To reduce the amount of static electricity generated, do not conduct assembly and other work under dry conditions.
 - 10.1.8.4 The LCD Module is coated with a film to protect the display surface. Be care when peeling off this protective film since static electricity may be generated.

b. Storage precautions

- i. When storing the LCD modules, avoid exposure to direct sunlight or to the light of fluorescent lamps.
- ii. The LCD modules should be stored under the storage temperature range. If the LCD modules will be stored for a long time, the recommend condition is:
Temperature : 0°C ~ 40°C Relatively humidity: ≤80%
- iii. The LCD modules should be stored in the room without acid, alkali and harmful gas.

c. Transportation Precautions

- i. The LCD modules should be no falling and violent shocking during transportation, and also should avoid excessive press, water, damp and sunshine.

The information contained herein is the exclusive property of TIANMA MICRO-ELECTRONICS Corporation and shall not be distributed, reproduced, or disclosed in whole or in part without prior written permission of TIANMA MICRO-ELECTRONICS Corporation.