

## BOE LCD Module Specification

Module P/N: JH103N00900

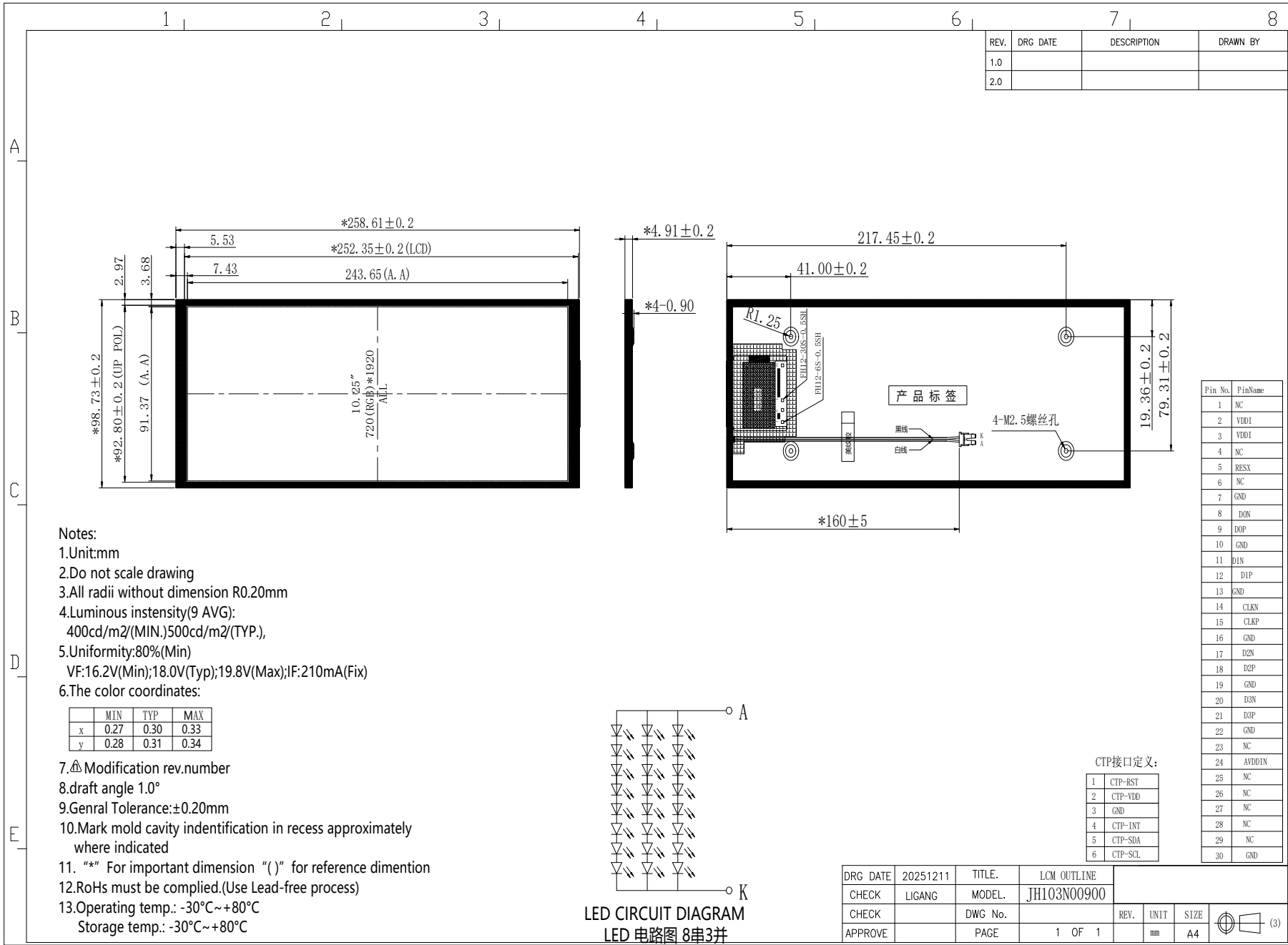
Version: 1.0

Description : 10.25inch TFT 720\*1920 Pixels with  
LED backlight, wide viewing angle

## 1.General Features

Item	Spec	Remark
Display Mode	Normally Black ,transmissive	
Viewing Direction	ALL Viewing	
Input Signals	MIPI	
Outline Dimensions	98.73(W)×258.61(H)×4.91(D) .	mm/With
Active Area	91.37(W)×243.65(H)	mm
Number of Pixels	720×RGB×1920 Pixels	
Dot Pitch	0.1269(H)×0.1269 (V)	mm
Pixel Arrangement	RGB Vertical stripes	
Drive IC	FT8201S	

2.Outline Dimension



REV.	DRG DATE	DESCRIPTION	DRAWN BY
1.0			
2.0			

Notes:

- Unit:mm
- Do not scale drawing
- All radii without dimension R0.20mm
- Luminous intensity(9 AVG): 400cd/m2(MIN.)500cd/m2(TYP.),
- Uniformity:80%(Min)  
VF:16.2V(Min);18.0V(Typ);19.8V(Max);IF:210mA(Fix)
- The color coordinates:

	MIN	TYP	MAX
x	0.27	0.30	0.33
y	0.28	0.31	0.34

- Modification rev.number
- draft angle 1.0°
- Genral Tolerance:±0.20mm
- Mark mold cavity indentification in recess approximately where indicated
- "\*" For important dimension "(" for reference dimation
- RoHs must be complied.(Use Lead-free process)
- Operating temp.: -30°C~+80°C  
Storage temp.: -30°C~+80°C

Pin No.	PinName
1	NC
2	VDD1
3	VDD1
4	NC
5	RESX
6	NC
7	GND
8	D0N
9	D0P
10	GND
11	D1N
12	D1P
13	GND
14	CLKN
15	CLKP
16	GND
17	D2N
18	D2P
19	GND
20	D3N
21	D3P
22	GND
23	NC
24	AVDDIN
25	NC
26	NC
27	NC
28	NC
29	NC
30	GND

CTP接口定义:

1	CTP-RST
2	CTP-VDD
3	GND
4	CTP-INT
5	CTP-SDA
6	CTP-SCL

DRG DATE	20251211	TITLE.	LCM OUTLINE	REV.	UNIT	SIZE	(3)
CHECK	LIGANG	MODEL.	JH103N00900				
CHECK		DWG No.					
APPROVE		PAGE	1 OF 1		mm	A4	

LED CIRCUIT DIAGRAM  
LED 电路图 8串3并

### 3. Reliability and Inspection Standard

No.	Test Item		Test Conditions	INSPECTION AFTER TEST
1	High Temperature	Storage	70°C, 120Hrs	Inspection after 2-4hours storage at room temperature,the samples should be free from defects: 1,Air bubble in the LCD. 2,Seal leak. 3,Non-display. 4,Missing segments. 5,Glass crack. 6,Current IDD is twice higher than initial value. 7,The surface shall be free from damage.
		Operation	70°C, 120Hrs	
2	Low Temperature	Storage	-30°C, 120Hrs	
		Operation	-20°C, 120Hrs	
3	High Temperature and High Humidity		50°C,90%RH, 48Hrs	
4	Temperature Cycle(storage)		-20 ~ 60°C, 1H /cycle , Total 10 Cycles,	
5	Vibration Test		10Hz~150Hz, 100m/s <sup>2</sup> , 30min	
6	ESD Test		Voltage:±4KV R: 330Ω C: 150pF Air discharge, 10time	
7	Drop Test(package state)		300mm, concrete floor, 1corner, 3edges, 6 sides	1.After testing, cosmetic and electrical defects should not happen. 2.the product should remain at initial place 3.Product uncovered or package broken is not permitted.

#### REMARK:

- 1,The Test samples should be applied to only one test item.
- 2,Sample for each test item is 3pcs.
- 3,For Damp Proof Test, Pure water(Resistance > 10MΩ)should be used.
- 4,Failure Judgment Criterion: Basic Specification Electrical Characteristic, Mechanical Characteristic, Optical Characteristic.

## 4. Absolute Maximum Ratings

(AVDD = 4.5V ~ 6.5V, AVEE = -4.5V ~ -6.5V, VDDI = 1.65V ~ 1.95V, Ta = -30°C ~ 85°C)

Parameter	Symbol	Rating	Unit	Note
Power Supply Voltage 1	VDDI-VSS	-0.3 ~ +1.95	V	
Power Supply Voltage 2	VDD-VSS	-0.3 ~ +1.35	V	
Power Supply Voltage 3	AVDD-VSS	-0.3 ~ +6.5	V	
Power Supply Voltage 4	VSS-AVEE	-0.3 ~ +6.5	V	
Power Supply Voltage 5	VGH-VGL	-0.3 ~ +32	V	
Input Voltage	Vt	-0.3 ~ VDDI+0.3	V	

Note1. The maximum applicable voltage on any pin with respect to 0V.

Note2. Device is subject to be damaged permanently if stresses beyond those absolute maximum ratings listed above.

## 5. Electrical Specification

Item	Sym.	Min	Typ.	Max	Unit	Note	
Power for Circuit Driving	AVDD	9	10	11	V		
	DVDD	1.7	1.8	1.9	V		
Logic Input Voltage	Low Voltage	V <sub>IL</sub>	0	-	0.3 IOVCC	V	
	High Voltage	V <sub>IH</sub>	0.7 IOVCC	-	IOVCC	V	
Logic Output Voltage	Low Voltage	V <sub>OL</sub>	0	-	0.2 IOVCC	V	
	High Voltage	V <sub>OH</sub>	0.8 IOVCC	-	IOVCC	V	

## 6. Driving Backlight

Item	Sym.	Min	Typ.	Max	Unit	Note
Backlight driving voltage	V <sub>BL</sub>	16.2	-	19.8	V	
Backlight driving current	I <sub>BL</sub>	-	210	-	mA	
Life Time	-	10,000	20,000	-		Note 3

Note 1: (Unless specified, the ambient temperature  $T_a=25^{\circ}\text{C}$ )

Note 2: The recommended operating conditions refer to a range in which operation of this product is guaranteed. Should this range is exceeded, the operation cannot be guaranteed even if the values may be without the absolute maximum ratings.

Note 3: If LED is driven by high current, high ambient temperature & humidity condition. The life time of LED will be reduced. Operating life means brightness goes down to 50% initial brightness. Typical operating life time is estimated data.

### 7.Optical Specifications

Optical characteristics are determined after the unit has been 'ON' and stable for approximately 30 minutes in a dark environment at 25 °C. The values specified are at an approximate distance 500mm from the LCD surface at a viewing angle of  $\Phi$  and  $\theta$  equal to 0°.

Item	Sym.	Values			Unit	Note
		Min.	Typ.	Max.		
1)Contrast Ratio	C/R	900	1200	-		FIG.1
2)Luminance Uniformity	$\delta$ WHITE	70	80	-	%	Note5
3)Luminance	L	400	500	-	cd/m <sup>2</sup>	
4)Response time	Tr	-	-	35	ms	FIG.2
	Tf					
5)Viewing Angle	$\theta_T$	-	80	-	Degree	FIG.3
	$\theta_B$	-	80	-		
	$\theta_L$	-	80	-		
	$\theta_R$	-	80	-		
6)Chromaticity	Wx	Typ -0.03	TBD	Typ +0.03		
	Wy		TBD			
	Rx		-			
	Ry		-			
	Gx		-			
	Gy		-			
	Bx		-			
	By		-			
NTSC		70%				TYP

## ◆ Measurement System

Notes:

1. Contrast Ratio(CR) is defined mathematically as :

$$\text{Contrast Ratio} = \frac{\text{Surface Luminance with all white pixels}}{\text{Surface Luminance with all black pixels}}$$

2. Surface luminance is the center point across the LCD surface 500mm from the surface with all pixels displaying white. For more information see FIG 1.

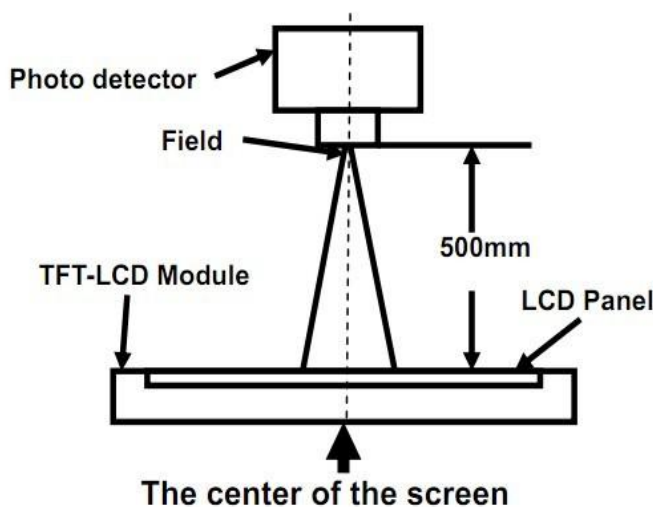
3. Response time is the time required for the display to transition from white to black (Rising Time, Tr) and from black to white (Falling Time, Tf). For additional information see FIG 2.

4. Viewing angle is the angle at which the contrast ratio is greater than 10. The angles are determined for the horizontal or x axis and the vertical or y axis with respect to the z axis which is normal to the LCD surface. For more information see FIG 3..

5. The uniformity in surface luminance ( δ WHITE ) is determined by measuring luminance at each test position 1 through 9, and then dividing the maximum luminance of 9 points luminance by minimum luminance of 9 points luminance.

$$\delta \text{ WHITE} = \frac{\text{Minimum Surface Luminance with all white pixels}}{\text{Maximum Surface Luminance with all white pixels}}$$

**FIG. 1 Optical Characteristic Measurement Equipment and Method**



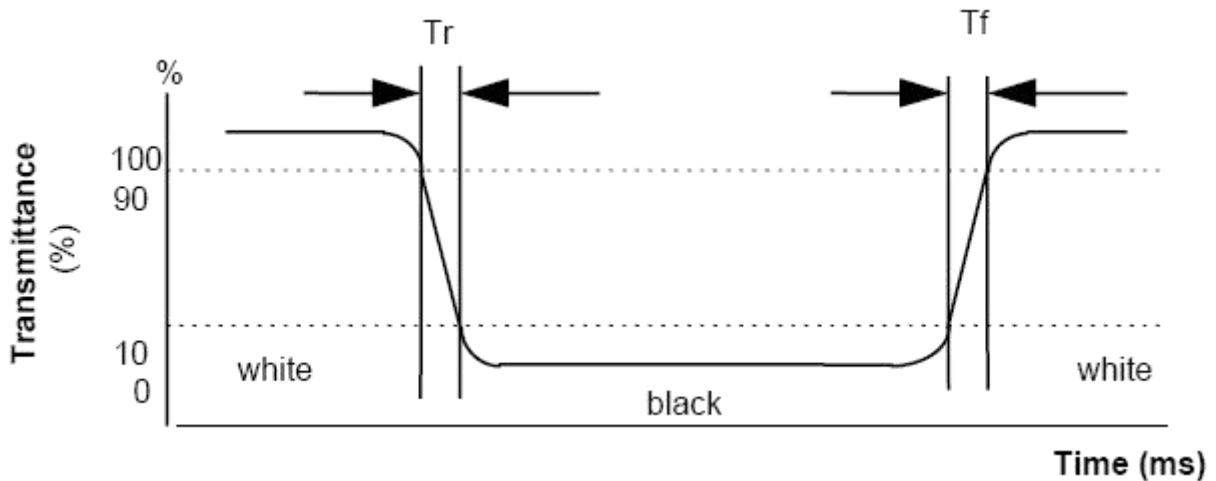
Item	Photo detector	Field
Contrast Ratio	SR-3A	1°
Luminance		
Chromaticity		
Lum Uniformity		
Response Time	BM-7A	2°

**FIG. 2 The definition of Response Time**

The response time is defined as the following figure and shall be measured by switching the input signal for “black” and “white”.

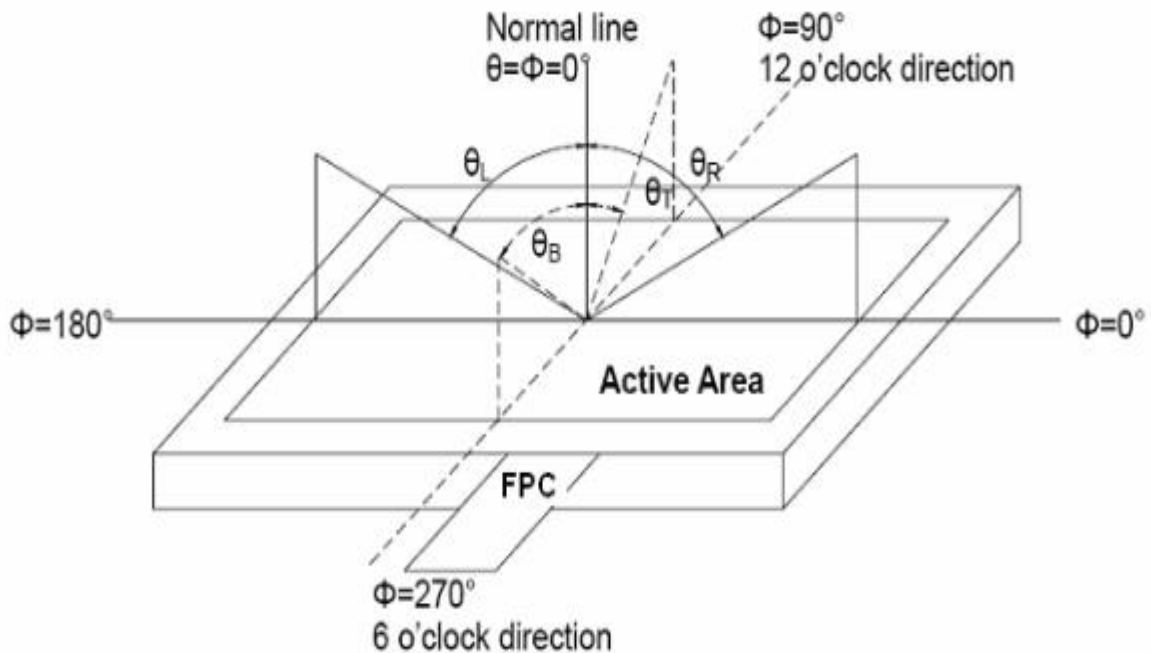
Response Time = Rising Time( $T_r$ ) + Falling Time( $T_f$ )

- Rising Time( $T_r$ ) : Full White 90% → Full White 10% Transmittance.
- Falling Time( $T_f$ ) : Full White 10% → Full White 90% Transmittance.

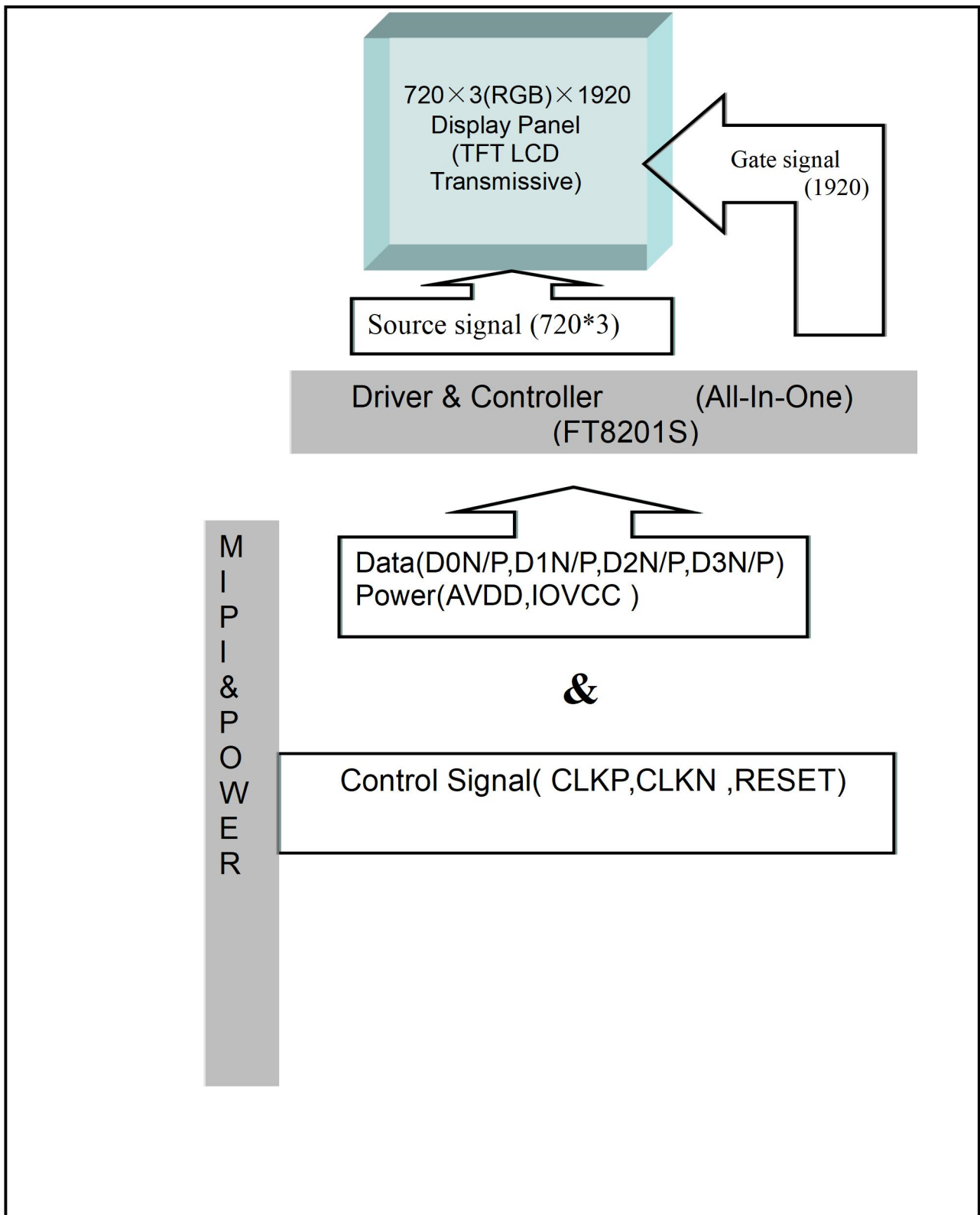


**FIG. 3 The definition of Viewing Angle**

Use Fig. 1(Test Procedure) under Measurement System to measure the contrast from the measuring direction specified by the conditions as the following figure.



## 8.Block Diagram



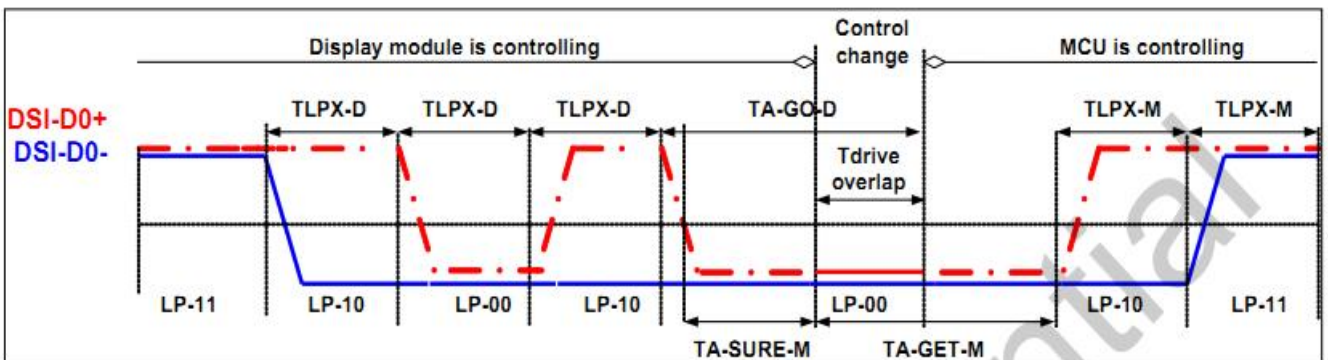
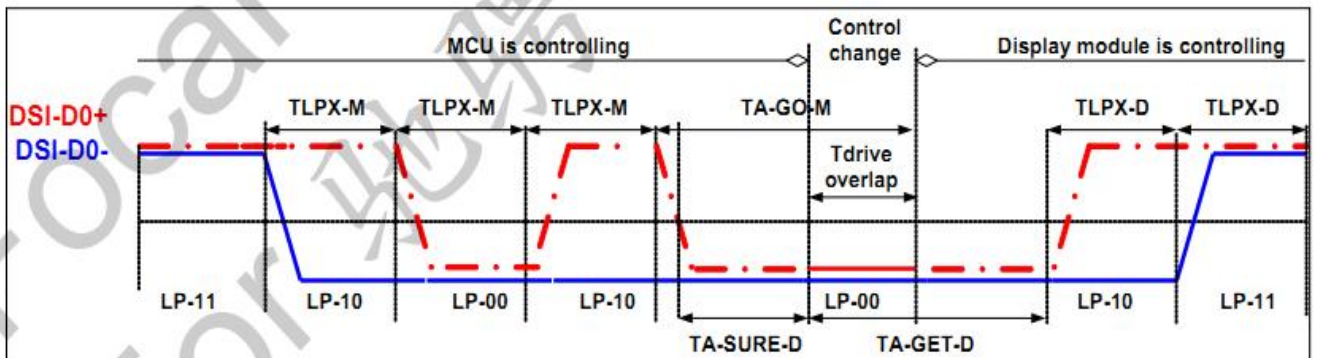
## 9.Pin Description

Item	Terminal	Functions
1	VCOM	NC
2	DVDD	Power for Digital Circuit (1.8V)
3	DVDD	Power for Digital Circuit (1.8V)
4	NC	NC
5	RESET	Global reset pin. Active Low to enter Reset State.
6	STBYB	NC
7	GND	Ground
8	MIPI_D0-	Negative MIPI differential data inputs0-
9	MIPI_D0+	Positive MIPI differential data inputs0+
10	GND	Ground
11	MIPI_D1-	Negative MIPI differential data inputs1-
12	MIPI_D1+	Positive MIPI differential data inputs1+
13	GND	Ground
14	MIPI_CLK-	Negative MIPI differential clock inputs
15	MIPI_CLK+	Positive MIPI differential clock inputs
16	GND	Ground
17	MIPI_D2-	Negative MIPI differential data inputs2-
18	MIPI_D2+	Positive MIPI differential data inputs2+
19	GND	Ground
20	MIPI_D3-	Negative MIPI differential data inputs3-
21	MIPI_D3+	Positive MIPI differential data inputs3+
22	GND	Ground
23	NC	NC
24	AVDD	Power for Analog Circuit (10V)
25	NC	NC
26	VGL	NC
27	NC	NC
28	VGH	NC
29	NC	NC
30	GND	Ground

# 10. Timing Characteristics

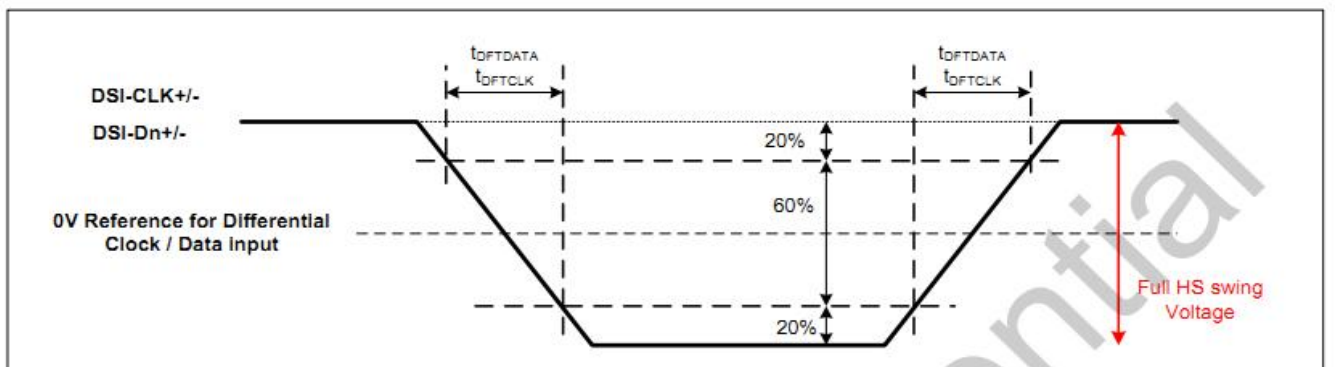
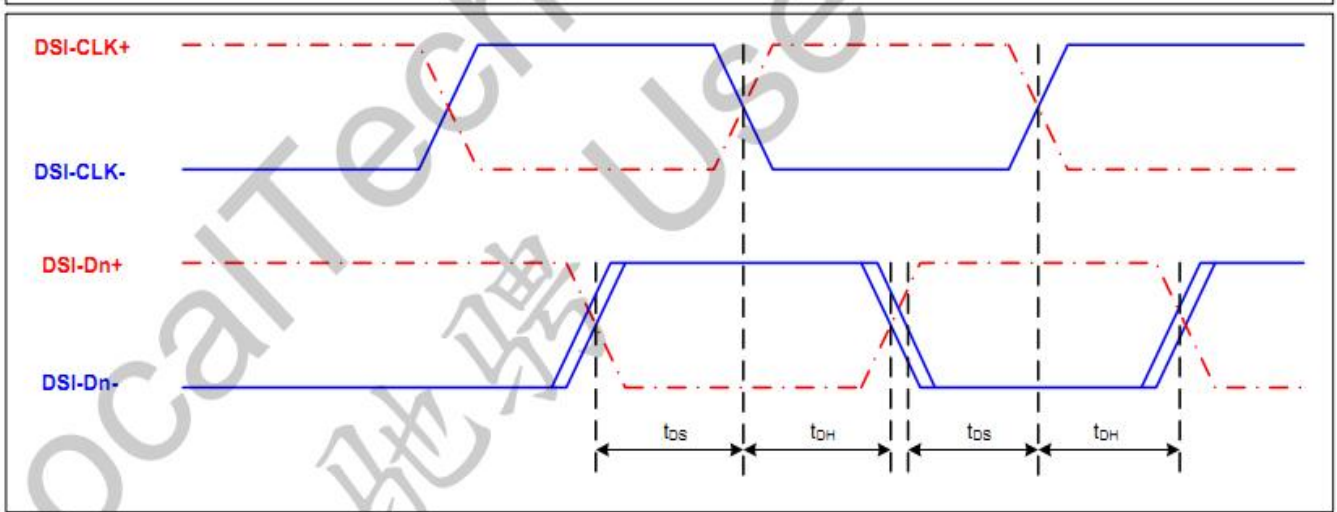
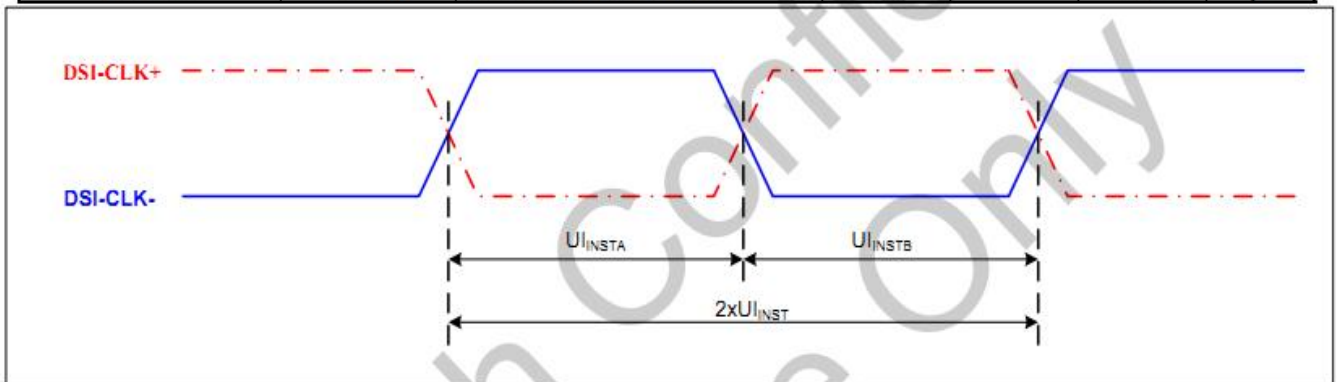
## 10.1. LP Power Mode Transmission

Parameter	Symbol	Parameter	Specification			Unit
			MIN	TYP	MAX	
<b>Low Power mode</b>						
DSI-D0+/-	$T_{LPX-M}$	Transmitted length of any Low-Power state period (MCU)	50	-	-	ns
DSI-D0+/-	$T_{TA-SURE-M}$	The display module waits after the LP-10 before transmitting the LP-00 (MCU)	$T_{LPX-M}$	-	$2XT_{LPX-M}$	ns
DSI-D0+/-	$T_{TA-GET-M}$	The display module drives the LP-00 before releasing MCU control	$5XT_{LPX-M}$	-	-	ns
DSI-D0+/-	$T_{TA-GO-M}$	The display drives the LP-00 after accepting control	$4XT_{LPX-M}$	-	-	ns
DSI-D0+/-	Ratio $T_{LPX}$	Ratio of ( $T_{LPX-M}/T_{LPX-D}$ ) for driving overlap	2/3	-	3/2	-
DSI-D0+/-	$T_{LPX-D}$	Transmitted length of any Low-Power state period (Display)	50	58	-	ns
DSI-D0+/-	$T_{TA-SURE-D}$	The MCU waits after the LP-10 before transmitting the LP-00 (Display)	$T_{LPX-D}$	-	$2XT_{LPX-D}$	ns
DSI-D0+/-	$T_{TA-GET-D}$	The MCU drives the LP-00 before releasing Display control	$5XT_{LPX-D}$	-	-	ns
DSI-D0+/-	$T_{TA-GO-D}$	The MCU drives the LP-00 after accepting control	$4XT_{LPX-D}$	-	-	ns



## 10.2 High Speed Mode Transmission

Parameter	Symbol	Parameter	Specification			Unit
			MIN	TYP	MAX	
<b>High Speed Mode</b>						
DSI-CLK+/-	$2xU_{INST}$	Double UI instantaneous	1.54	-	25	ns
DSI-CLK+/-	$U_{INSTA}, U_{INSTB}$	UI instantaneous Halfs	0.77	-	12.5	ns
DSI-Dn+/-	$t_{DS}$	Data to clock setup time	0.15	-	-	UI
DSI-Dn+/-	$t_{DH}$	Data to clock hold time	0.15	-	-	UI
DSI-CLK+/-	$t_{DRTCLK}$	Differential rise time for clock	150	-	0.3UI	ps
DSI-Dn+/-	$t_{DRTDATA}$	Differential rise time for data	150	-	0.3UI	ps
DSI-CLK+/-	$t_{DFTCLK}$	Differential fall time for clock	150	-	0.3UI	ps
DSI-Dn+/-	$t_{DFTDATA}$	Differential fall time for data	150	-	0.3UI	ps



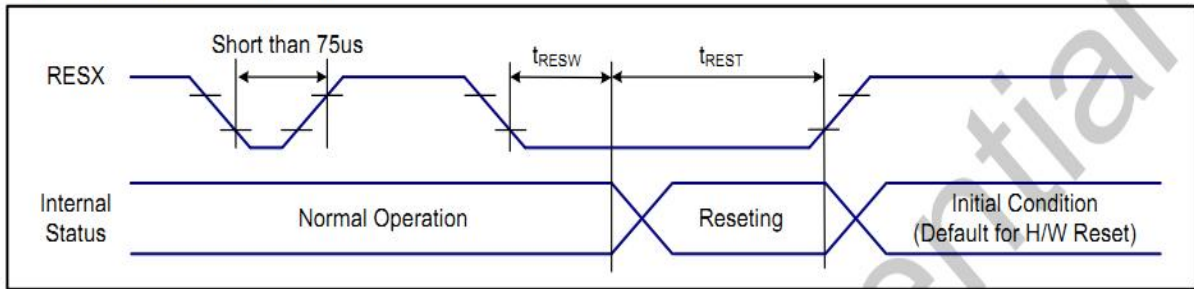
## 10.3 MIPI DC Character

(1a = -30°C ~ 85°C)

Parameter	Symbol	Conditions	Specification			Unit
			MIN	TYP	MAX	
<b>Power supply voltage for MIPI Interface</b>						
Power supply voltage for MIPI interface	LVDSVDD	-	1.2	1.25	1.3	V
<b>LPDT Input Characteristics</b>						
Pad signal voltage range	$V_I$	-	-50	-	1350	mV
Ground Shift	$V_{GND\text{SH}}$	-	-50	-	50	mV
Logic 0 input threshold	$V_{IL}$	-	-	-	550	mV
Logic 1 input threshold	$V_{IH}$	-	880	-	-	mV
Input hysteresis	$V_{HYST}$	-	25	-	-	mV
<b>LPDT Output Characteristics</b>						
Output low level	$V_{OL}$	-	-50	-	50	mV
Output high level	$V_{OH}$	Note 1	1.2	1.25	1.3	V
Logic 0 contention threshold	$V_{ILCD}$	-	-	-	200	mV
Logic 1 contention threshold	$V_{IHCD}$	-	450	-	-	mV
Output impedance of LPDT	$Z_{OLP}$	-	110	-	-	$\Omega$
<b>Hi-speed Input Characteristics</b>						
Single-end input low voltage	$V_{ILHS}$	-	-40	-	-	mV
Single-end input high voltage	$V_{IHHS}$	-	-	-	460	mV
Single-end threshold for HS termination enable	$V_{TERM-EN}$	-	-	-	450	mV
Differential input low threshold	$V_{IDTL}$	-	-70	-	-	mV
Differential input high threshold	$V_{IDTH}$	-	-	-	70	mV
Common mode voltage	$V_{CMRXDC}$	-	70	-	330	mV
Differential input impedance	$Z_{ID}$	-	80	100	125	$\Omega$

### 10.4. Reset Operation

$t_{RESW}$  shorter than 75us, Reset will be rejected.



VSS=0V, VDDI = 1.65V ~ 1.95V, Ta = -30°C to 85°C

Symbol	Parameter	MIN	TYP	MAX	Note	Unit
$t_{RESW}$	*1) Reset low pulse minimum width	150	-	-	Reset signal recognized	us
$t_{REST}$	*2) Reset complete time	5	-	120	Reset action complete	ms

Table: Reset input timing

Note 1. RESX low pulse that is too short does not cause irregular system reset according to the table below.

RESX Pulse	Action
Shorter than 75us	Reset Rejected
Longer than 150us	Reset Recognized
Between 75us and 150us	Reset sequence starts (It depends on voltage and temperature condition.)

Note 2. Once Reset low pulse is recognized, system requires RESX remaining low for another 5ms to complete H/W reset.

Note 3. During H/W Reset flow, ID0 ~ ID4 and VCOM value in OTP will be latched to internal register during this period. This loading is done every time when H/W reset is complete ; The H/W reset sequence is complete when RESX is remaining low longer than  $t_{RESW} + t_{REST}$ .

## 11.PRECAUTIONS FOR USING LCD MODULES

### Handing Precautions

- (1) The display panel is made of glass and polarizer. As glass is fragile, it tends to become or chipped during handling especially on the edges. Please avoid dropping or jarring. Do not subject it to a mechanical shock by dropping it or impact.
- (2) If the display panel is damaged and the liquid crystal substance leaks out, be sure not to get any in your mouth. If the substance contacts your skin or clothes, wash it off using soap and water.
- (3) Do not apply excessive force to the display surface or the adjoining areas since this may cause the color tone to vary. Do not touch the display with bare hands. This will stain the display area and degraded insulation between terminals (some cosmetics are determined to the polarizer).
- (4) The polarizer covering the display surface of the LCD module is soft and easily scratched. Handle this polarizer carefully. Do not touch, push or rub the exposed polarizers with anything harder than an HB pencil lead (glass, tweezers, etc.). Do not put or attach anything on the display area to avoid leaving marks on. Condensation on the surface and contact with terminals due to cold will damage, stain or dirty the polarizer. After products are tested at low temperature they must be warmed up in a container before coming is contacting with room temperature air.
- (5) If the display surface becomes contaminated, breathe on the surface and gently wipe it with a soft dry cloth. If it is heavily contaminated, moisten cloth with one of the following solvents
  - Isopropyl alcohol
  - Ethyl alcoholDo not scrub hard to avoid damaging the display surface.
- (6) Solvents other than those above-mentioned may damage the polarizer. Especially, do not use the following.
  - Water
  - Ketone
  - Aromatic solventsWipe off saliva or water drops immediately, contact with water over a long period of time may cause deformation or color fading. Avoid contacting oil and fats.
- (7) Exercise care to minimize corrosion of the electrode. Corrosion of the electrodes is accelerated by water droplets, moisture condensation or a current flow in a high-humidity environment.
- (8) Install the LCD Module by using the mounting holes. When mounting the LCD module make sure it is free of twisting, warping and distortion. In particular, do not forcibly pull or bend the I/O cable or the backlight cable.
- (9) Do not attempt to disassemble or process the LCD module.
- (10) NC terminal should be open. Do not connect anything.
- (11) If the logic circuit power is off, do not apply the input signals.
- (12) Since LCM has been assembled and adjusted with a high degree of precision, avoid applying excessive shocks to the module or making any alterations or modifications to it.
  - Do not alter, modify or change the shape of the tab on the metal frame.
  - Do not make extra holes on the printed circuit board, modify its shape or change the positions of components to be attached.
  - Do not damage or modify the pattern writing on the printed circuit board.
  - Absolutely do not modify the zebra rubber strip (conductive rubber) or heat seal connector.

- Except for soldering the interface, do not make any alterations or modifications with a soldering iron.
- Do not drop, bend or twist LCM.

### **Storage Precautions**

When storing the LCD modules, the following precaution is necessary.

- (1) Store them in a sealed polyethylene bag. If properly sealed, there is no need for the dessicant.
- (2) Store them in a dark place. Do not expose to sunlight or fluorescent light, keep the temperature between 0°C and 35°C.
- (3) The polarizer surface should not come in contact with any other objects. (We advise you to store them in the container in which they were shipped).

### **Others**

Liquid crystals solidify under low temperature (below the storage temperature range) leading to defective orientation or the generation of air bubbles (black or white). Air bubbles may also be generated if the module is subject to a low temperature.

If the LCD modules have been operating for a long time showing the same display patterns, the display patterns may remain on the screen as ghost images and a slight contrast irregularity may also appear. A normal operating status can be regained by suspending use for some time. It should be noted that this phenomenon does not adversely affect performance reliability.

To minimize the performance degradation of the LCD modules resulting from destruction caused by static electricity etc., exercise care to avoid holding the following sections when handling the modules.

- Exposed area of the printed circuit board.
- Terminal electrode sections.