

DOCUMENT NUMBER AND REVISION  
**FS\_V1\_3.1\_COG-VLBJT207-03\_B**  
**(COG-VLBJT207-03)**

DOCUMENT TITLE:  
**SPECIFICATION**  
**OF**  
**TFT MODULE TYPE**

CUSTOMER	
CUSTOMER PART NO.	NA
MODEL NUMBER	COG-VLBJT207-03
CUSTOMER APPROVAL	魏进元 孙大敬 郑志奇
DATE	

DEPARTMENT	NAME	SIGNATURE	DATE
PREPARED BY	ZHU YANG NA	zhu yang na	2025.06.16
CHECKED BY	XIE KUN NAN	谢坤南	2025.06.16
APPROVED BY EE	TAN WEN HAO / DENG DEVIN CD	檀文豪	2025.06.16
APPROVED BY MOE	LI IRIS/ YANG WAN TAO	李雪丽	2025.06.16
QUALITY BY QA	MA XIAN ZHI	马先志	2025.06.16
QUALITY BY CS	HUANG HAI ZHOU	黄海周	2025.06.16

DISTRIBUTION LIST: MARKETING

### DOCUMENT REVISION HISTORY:

DOCUMENT REVISION FROM TO	DATE	DESCRIPTION	CHANGED BY	CHECKED BY
A	2025.03.18	First Release	ZHU YANG NA	HUANG GG
A B	2025.06.16	Items 1 to 6 were updated: 1.) (Whole Document) Preliminary Specification were updated to Full Specification. 2.) (Page 5, Point 1.3) Table 1 was updated. 3.) (Page 7, Figure 1) Module specification was updated. 4.) (Page 29, Point 8.1) Inspection Conditions was updated. 5.) (Page 33, Point 8.3.3) Other defect was updated. 6.) (Page 38~41, Point 9) Packing Specification.	ZHU YANG NA	XIE KUN NAN

## CONTENTS

<b>DOCUMENT REVISION HISTORY:</b> .....	<b>2</b>
<b>1. GENERAL DESCRIPTION</b> .....	<b>5</b>
<b>1.1 INTRODUCTION</b> .....	<b>5</b>
<b>1.2 APPLICATION</b> .....	<b>5</b>
<b>1.3 GENERAL SPECIFICATIONS</b> .....	<b>5</b>
<b>2. MECHANICAL SPECIFICATIONS</b> .....	<b>6</b>
<b>3. INTERFACE SIGNALS</b> .....	<b>8</b>
3.1 TFT-LCD PANEL DRIVING .....	8
<b>4. ABSOLUTE MAXIMUM RATINGS</b> .....	<b>12</b>
<b>5. ELECTRICAL SPECIFICATIONS</b> .....	<b>13</b>
5.1 BLOCK DIAGRAM .....	13
5.2 TYPICAL ELECTRICAL CHARACTERISTICS FOR TFT-LCD .....	14
5.3 TFT-LCD TIMING CHARACTERISTICS .....	15
5.3.1 LVDS AC Characteristics .....	15
5.3.2 LVDS Input Data Format .....	17
5.3.3 Video Signal Timing .....	18
5.3.4 SSC (spread spectrum clock) .....	19
5.3.5 SPI interface (3 wires) .....	20
5.3.6 SPI interface timing chart .....	21
5.3.7 Reset Timing .....	21
5.4 POWER ON / OFF SEQUENCE .....	22
5.5 THERMISTORS RESISTANCE .....	23
<b>6. OPTICAL CHARACTERISTICS</b> .....	<b>24</b>
<b>7. RELIABILITY TESTS / ENVIRONMENTAL</b> .....	<b>27</b>
7.1 RELIABILITY TEST CONDITIONS .....	27
7.2 ELECTROSTATIC DISCHARGE (ESD) .....	28
<b>8. INSPECTION CRITERIA</b> .....	<b>29</b>
8.1 INSPECTION CONDITIONS 检查条件 .....	29
8.2 VISUAL INSPECTION CRITERIA .....	30

8.3	APPEARANCE INSPECTION CRITERIA .....	32
8.3.1	TFT Panel defects (apply to single cell/FOG/MDL production).....	32
8.3.2	FPC defects, FPC 缺陷.....	32
8.3.3	Other defect.....	33
8.4	BOE 客户质量服务流程 ( BOE CUSTOMER QUALITY SERVICE PROCESS ) .....	34
8.5	THE WARRANTY WILL BE AVOIDED 质保期失效: .....	34
8.6	SERVICE SCOPE ON WARRANTY PART WHICH CONFIRMED BY BOE ITS RESPONSIBILITY: .....	35
8.7	CAUTION FOR OPERATION 操作注意事项 .....	35
<b>9.</b>	<b>PACKING SPECIFICATION .....</b>	<b>38</b>
<b>10.</b>	<b>HANDLING CAUTIONS .....</b>	<b>42</b>
10.1	PACKING REMOVAL AND HANDLING REQUIREMENT .....	42
10.2	MOUNTING OF MODULE .....	44
10.3	PRECAUTIONS IN MOUNTING .....	44
10.4	ADJUSTING MODULE .....	44
10.5	OTHERS .....	44
<b>11.</b>	<b>DEFINITIONS .....</b>	<b>45</b>
<b>12.</b>	<b>LIFE SUPPORT APPLICATIONS .....</b>	<b>45</b>
<b>13.</b>	<b>APPENDIX .....</b>	<b>45</b>

**BOE VARITRONIX LIMITED****Specification  
Of  
TFT Module Type  
Model No.: COG-VLBJT207-03****1. General Description****1.1 Introduction**

This is a 3.1-inch TFT Module. And this model is composed, TFT-LCD Panel.

**1.2 Application**

- Automotive

**1.3 General Specifications**Table 1: General Specifications

Parameters	Specifications	Unit
Display Size (Diagonal)	3.1"	inch
Aspect Ratio	5:3 (landscape)	-
Number of Pixels (H x V)	800 x RGB x 480	-
Color Configuration	RGB vertical stripes	
PPI	297	pixels
Pixels Shape	Square	-
LCD Type	ADS, transmissive, LTPS LCD Panel	-
Color Resolution	8-bit 16.7M colors	-
Image Mode	Normally Black	-
Contrast Ratio @Ta = 25°C	Min. 1000: 1 (Perpendicular viewing)	-
Viewing Angle (12/6/9/3 o'clock) <sup>(Note 1)</sup>	All directions	degree
Operating Temperature	-40 to +105(No Performance guaranteed below -30° C)	°C
Storage Temperature	-40 to +105	°C
Regulation	RoHS & Reach compliant	-
<b>Electronics and Interface</b>		

TFT Display Interface Method	<ul style="list-style-type: none"> <li>• 1 port LVDS interface &amp; 3 lines SPI interface</li> <li>• 30-pin CON</li> </ul>	-
<b>Basic Display Features (TFT)</b>		
Visibility with Polarized Sunglass	Visible at landscape	-
Display Power Consumption	Typ. 269±10%	mW

Note:

1. At the U/D/L/R direction, the viewing angle is same;

## 2. Mechanical Specifications

The mechanical detail is shown in Fig. 1 and summarized in Table 2 below.

Table 2: Module mechanical detail

Parameters		Specifications	Unit
Outline dimensions		81.0(W) x 56.9(H) x 2.8(D)(Include protective film) (Exclude FPC, cables, post & component)	mm
Color TFT 800 x RGB x 480	Housing opening	72.4(W) x 45.4(H)	mm
	Active area	68.4(W) x 41.04(H)	
	Sub-Pixel pitch	0.0285(*3)(W) x 0.0855(H)	mm
Weight		Approx:23.69±10%	gram

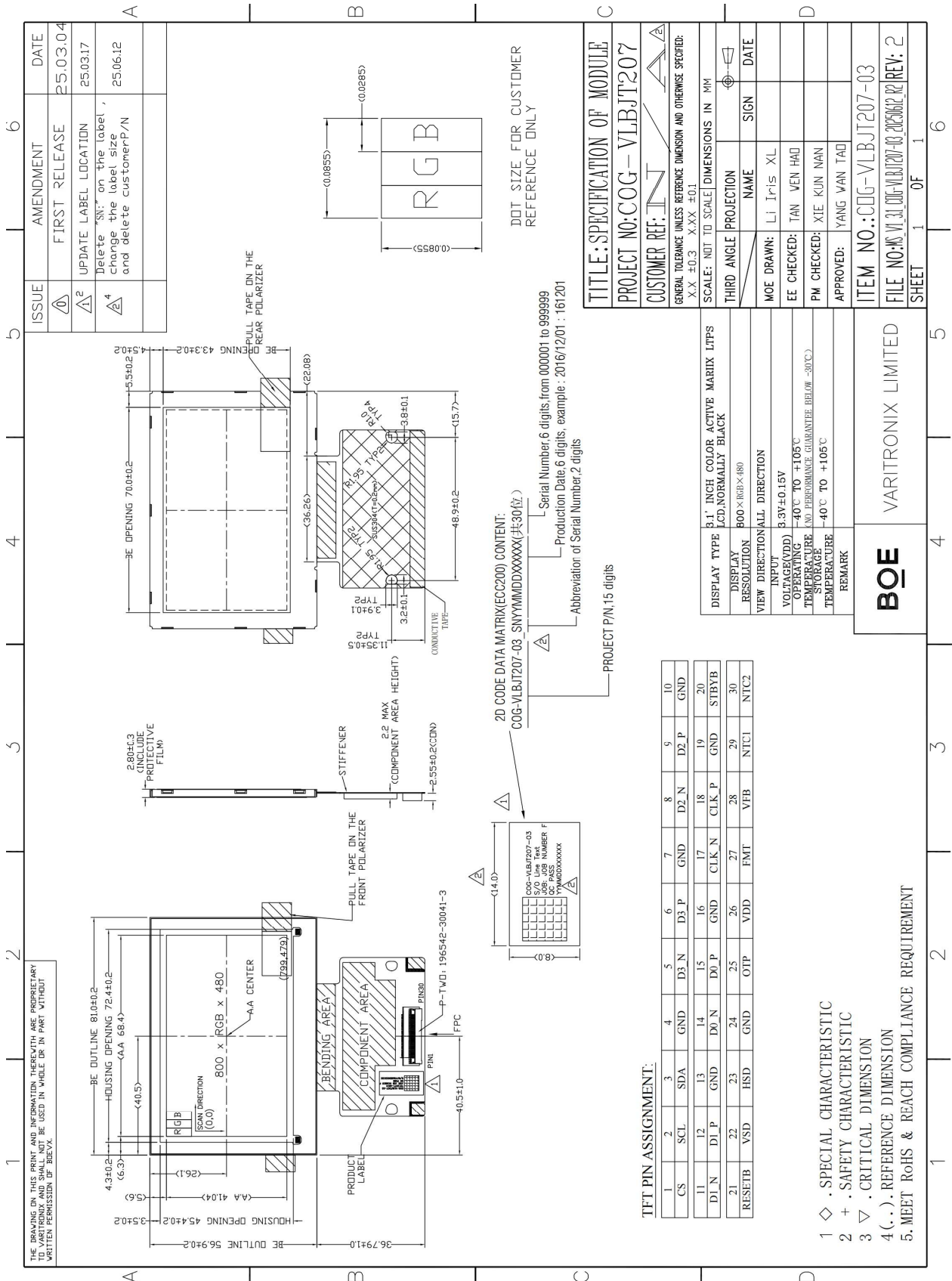

Figure 1: Module specification

### 3. Interface Signals

#### 3.1 TFT-LCD Panel Driving

Recommend connector item(CON): P-TWO “196542-30041-3”

Table 3: Connector Pin Assignments for TFT

Pin No.	Symbol	I/O	Description	Remark
1	CS	I	Serial Interface chip enable signal for SPI interface. CS=0: Selected (Accessible) CS=1: Not selected (Inaccessible) .	Set this pin to “H” when not in use
2	SCL	I	Serial interface clock input for SPI interface.	Set this pin to “L” when not in use
3	SDA	I/O	Serial interface address and data input/output for SPI interface.	Set this pin to “L” when not in use
4	GND	P	Ground.	
5	D3_N	I	LVDS differential data Signal 3-	Note1.
6	D3_P	I	LVDS differential data Signal 3+	Note1.
7	GND	P	Ground.	
8	D2_N	I	LVDS differential data Signal 2-	Note1.
9	D2_P	I	LVDS differential data Signal 2+	Note1.
10	GND	P	Ground.	
11	D1_N	I	LVDS differential data Signal 1-	Note1.
12	D1_P	I	LVDS differential data Signal 1+	Note1.
13	GND	P	Ground.	
14	D0_N	I	LVDS differential data Signal 0-	Note1.
15	D0_P	I	LVDS differential data Signal 0+	Note1.
16	GND	P	Ground.	
17	CLK_N	I	LVDS differential CLK Signal-	Note1.
18	CLK_P	I	LVDS differential CLK Signal+	Note1.
19	GND	P	Ground.	
20	STBYB	I	Standby mode setting pin, active low.	H: Normal display L: Standby mode
21	RESETB	I	Global reset pin, active low.	H: Normal display L: Reset state Note5.
22	VSD(TB)	I	Vertical shift direction (Gate output) selection.	Note2.
23	HSD(LR)	I	Horizontal shift direction (Source output) selection.	Note2.
24	GND	P	Ground.	
25	OTP	P	Power input for OTP programming, Connect it to VDD when not used	
26	VDD	P	Power input pin.	Typ: 3.3V

Pin No.	Symbol	I/O	Description	Remark
27	FMT	-	Dummy pin. Reserved for FMT pin	
28	VFB	O	Fail detection signal output.	H: Normal display L: Abnormal Note 4
29	NTC1	C	NTC pin 1	
30	NTC2	C	NTC pin 2	

Remark: For I/O, “I” is input, “O” is output, “P” is power; “C” is passive

Note1: These pins already have a 100+/-10 Ohm terminal resistance on module FPCA.

Note2: **LCD Scanning Direction.** Original data to transfer:



LCD Scanning Direction	
VSD=H, HSD =H	VSD=H, HSD =L
VSD=L, HSD =H	VSD=L, HSD =L

Figure 2

Note 3: The orientation of the module, please refer to module drawing.

Note 4: Any one of the following cases will trigger the fail detect function to set the FAIL\_DET to low.

- A. Input signals are detected fail to enter self protection mode.
- B. STV signal is detected fail for tradition Gate driver only.
- C. Internal source signal output fail.
- D. Abnormal low voltages are detected to enter GAS function.
- E. Input LVDS signals are unlock.
- F. GIP failed detect
- G. OVP (over voltage protection. Include: VCC1/2, VDDD, VSP, VSN, VGH, VGL, VCL, VCOM, VGMP L, VGMNL).

H. LVD (low voltage detection. Include: VGH, VCL, VCOM, VSDP, VSDN, VGMPH, VGMNH).

Fail flag can be read by SPI interface: write (0x00,0x19); read 0x01/02/03/03/04/05/06;

Fail flag register table: Page 25(0x19)

Address	Default	Read/Write	D[7:0]	Name	Description	Remark
00h	0Ch	R/W	[7:0]	PAGE[7:0]		-
01h	00h	R	[7]	PFM NG fail	Fail flag Group1 (0:OK, 1: fail)	Read only
		R	[6]	OTP trim fail		
		R	[5]	EEPROM fail		
		R	[4]	No-VIDEO fail		
		R	[3]	Gate fail		
		R	[2]	SD DET fail		
		R	[1]	OTP full fail		
		R	[0]	LVDS lock fail		
02h	00h	R	[7]	GAS VGL fail	Fail flag Group2 (0:OK, 1: fail)	Read only
		R	[6]	GAS PFM fail		
		R	[5]	GAS VCC fail		
		R	[4]	CRC check fail		
		R	[3]	AGM P/N check sum fail		
		R	[2]	OTP check sum fail		
		R	[1]	OTP reload fail		
		R	[0]	-	Reserved.	
03h	00h	R	[7]	OVP VCC fail	Fail flag Group3 (0:OK, 1: fail)	Read only
		R	[6]	OVP VSP fail		
		R	[5]	OVP VSN fail		
		R	[4]	OVP VGH fail		
		R	[3]	OVP VGL fail		
		R	[2]	OVP VCOM fail		
		R	[1]	LVD VGH fail		
		R	[0]	LVD VCOM fail		
04h	00h	R	[7]	OVP VGMPH fail	Fail flag Group4 (0:OK, 1: fail)	Read only
		R	[6]	OVP VGMNL fail		
		R	[5]	OVP VDDD fail		
		R	[4]	OVP VCL fail		
		R	[3]	LVD VGMPH fail		
		R	[2]	LVD VGMNH fail		
		R	[1]	LVD VSDPN fail		
		R	[0]	LVD VCL fail		
05h	00h	R	[7]	PFM NG fail	Group1: Power on fail flag test (0:OK, 1: fail)	Read only
		R	[6]	OTP reload fail		
		R	[5]	EEPROM fail		
		R	[4]	No-video fail		
		R	[3]	Gate fail		
		R	[2]	SOURCE fail		
		R	[1]	GAS		
		R	[0]	LVDS fail		
06h	00h		[7:2]	-	Reserved.	
		R	[1]	OVP check fail	Group2: Power on fail flag tes (0:OK, 1: fail)	Read only
		R	[0]	CRC check fail		

Note 5: RC circuit is included at below pin(s).

RC value for pins in module				
PINS	R <sub>u</sub> (K ohm)	C <sub>f</sub> (uF)	R <sub>s</sub> (K ohm)	CIRCUIT
STBYB	NC	NC	1	
RESETB	10	1uF	1	
VSD(TB)	-	-	1	
HSD(LR)	-	-	1	
VFB	-	-	NC	

## 4. Absolute Maximum Ratings

### 4.1 Electrical Maximum Ratings

The product or its functions may subject to permanent damage if it's stressed beyond those absolute maximum ratings listed below. Exposure to absolute maximum rating conditions for extended periods may affect display module reliability.

At GND=0V

Table 4: Absolute Maximum Ratings & Environmental Conditions

Item	Symbol	Min.	Max.	Unit
TFT supply voltage for Logic	VDD	-0.3	+4.0	V
TFT digital I/O input signal	V <sub>IO</sub>	-0.3	VDD+0.3	V
Relative Humidity (at 60°C) <sup>(Note 3)</sup>	RH		90	%
Operating Temperature <sup>(Note 1,2)</sup>	T <sub>opr</sub>	-40	+105	°C
Storage Temperature	T <sub>stg</sub>	-40	+105	°C

Note 1: Panel surface temperature should not exceed 105°C.

Note 2: Between -40°C to -30°C, display performance is not committed. But there should be no incorrect image and no damage to module.

Note 3: No condensation allowed under any condition.

#### **[Caution]**

Do not display fixed pattern for prolonged hours because it may develop image sticking on the display.

## 5. Electrical Specifications

### 5.1 Block Diagram

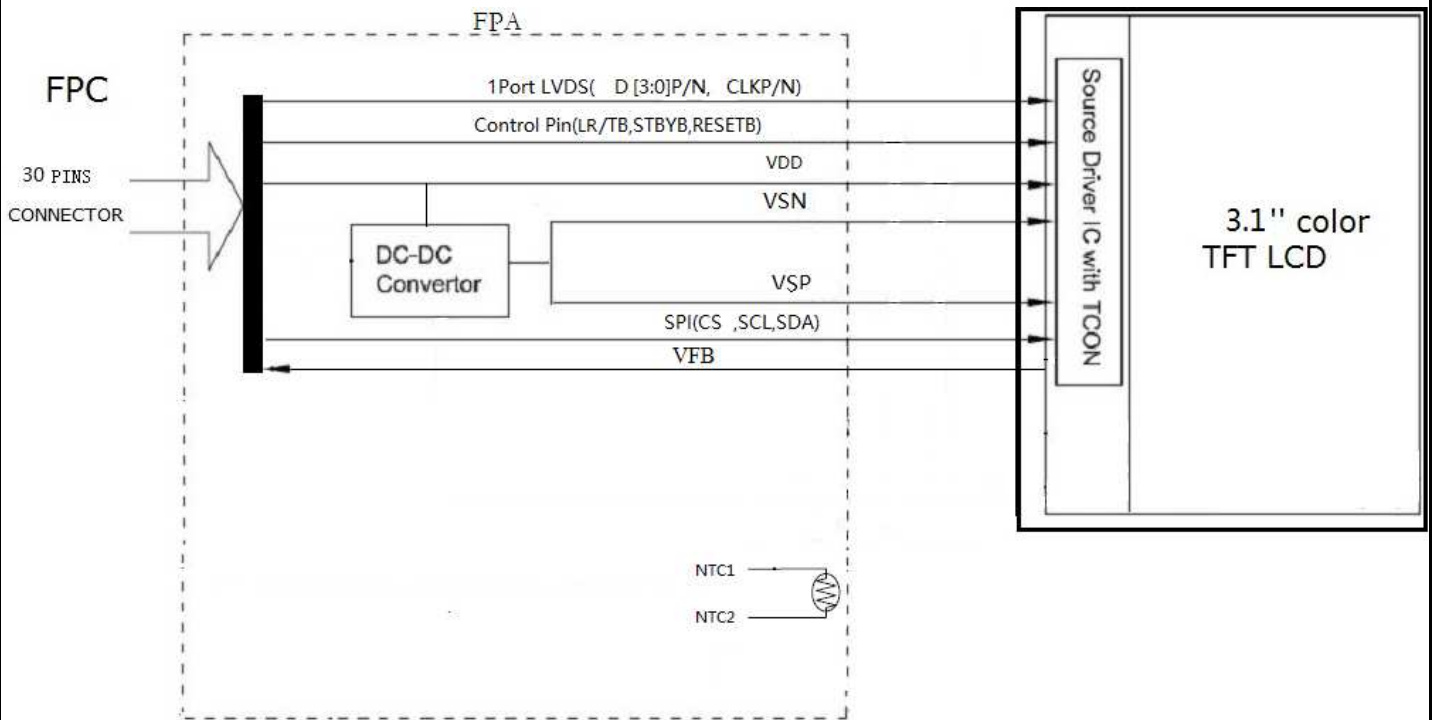

Figure 3: Block diagram

Remark: signals applied pins

1. Control Signals: RESETB, STBYB, VSD(TB), HSD(LR),
2. SPI Signals: CS, SCL, SDA
3. Video Signals: D[0:3]P/N, CLKP/N

## 5.2 Typical Electrical Characteristics for TFT-LCD

At Top = 25 °C, VDD=3.3V, GND=0V

Table 5: DC Characteristics for TFT LCD

Parameter	Symbol	Min.	Typ.	Max.	Unit
Power supply voltage	VDD (Note 1)	3.15	3.3	3.45	V
Power supply current	IVDD	-	60	90	mA
Driver input high signal voltage (Note 3)	VIH	0.7*VDD	-	VDD+0.3	V
Driver input low signal voltage (Note 3)	VIL	GND-0.3	-	0.3*VDD	V
Driver output high signal voltage (Note 3)	VOH	VDD-0.4	-	-	
Driver output low signal voltage (Note 3)	VOL	GND	-	GND+0.4	V

Note 1: The supply voltage is measured and specified at the interface connector of the module.

Note 2: Tested at all white pattern, Frame rate =60Hz. Tested value is RMS value.

Note 3: Applied pins: For SDA, SCL, CS, STBYB, RESETB, signals.

Table 6: LVDS DC Characteristics

Parameter	Symbol	Min.	Typ.	Max.	Unit
Differential input high threshold voltage	$V_{TH}$	-	-	+0.1	V
Differential input low threshold voltage	$V_{TL}$	-0.1	-	-	V
Differential input common mode voltage	$V_{CM}$	1	1.2	$1.7 -  V_{ID} /2$	V
LVDS input voltage	$V_{INLV}$	0.7	-	1.7	V
Differential input voltage	$ V_{ID} $	0.1	-	0.6	V
Differential input leakage current	$I_{lvleak}$	-10	-	+10	uA

Single End Signals:

CLKP/N  
 D[3:0]P/N

Differential Signals:

CLKP - CLKN  
 D[3:0]P - D[3:0]N

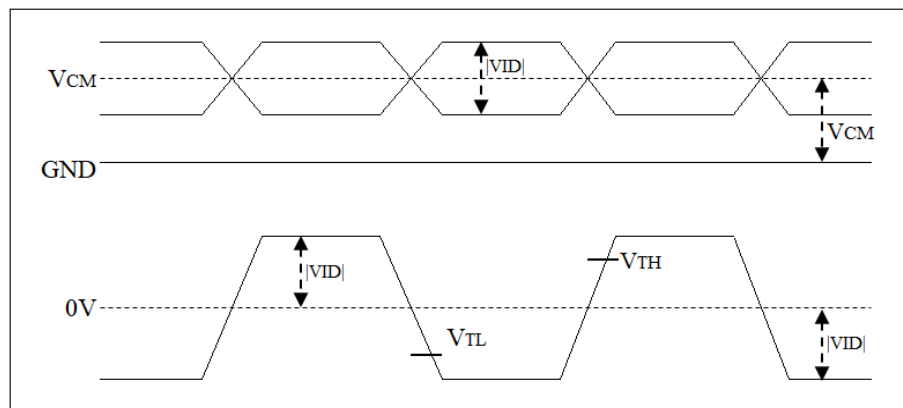

Figure 4: LVDS DC character

## 5.3 TFT-LCD Timing Characteristics

### 5.3.1 LVDS AC Characteristics

Table 7: LVDS AC Specification

Parameter	Symbol	Min.	Typ.	Max.	Unit
Clock frequency	FLVCYC	25.71	26.7	32.33	MHz
30.93Clock period	TLVCYC	30.93	37.45	38.9	ns
1 data bit time	UI		1/7		T <sub>LVCYC</sub>
Clock high time	TLVCH	-	4	-	UI
Clock low time	TLVCL	-	3	-	UI
Position 1	T <sub>POS1</sub>	-0.2	0	0.2	UI
Position 0	T <sub>POS0</sub>	0.8	1	1.2	UI
Position 6	T <sub>POS6</sub>	1.8	2	2.2	UI
Position 5	T <sub>POS5</sub>	2.8	3	3.2	UI
Position 4	T <sub>POS4</sub>	3.8	4	4.2	UI
Position 3	T <sub>POS3</sub>	4.8	5	5.2	UI
Position 2	T <sub>POS2</sub>	5.8	6	6.2	UI
Input eye width	T <sub>EYEW</sub>	0.6			UI
Input eye border	T <sub>EX</sub>			0.2	UI
LVDS wake up time	T <sub>ENLVDS</sub>			150	us
LVDS port to port skew	T <sub>SKREW_EO</sub>	-1		1	UI

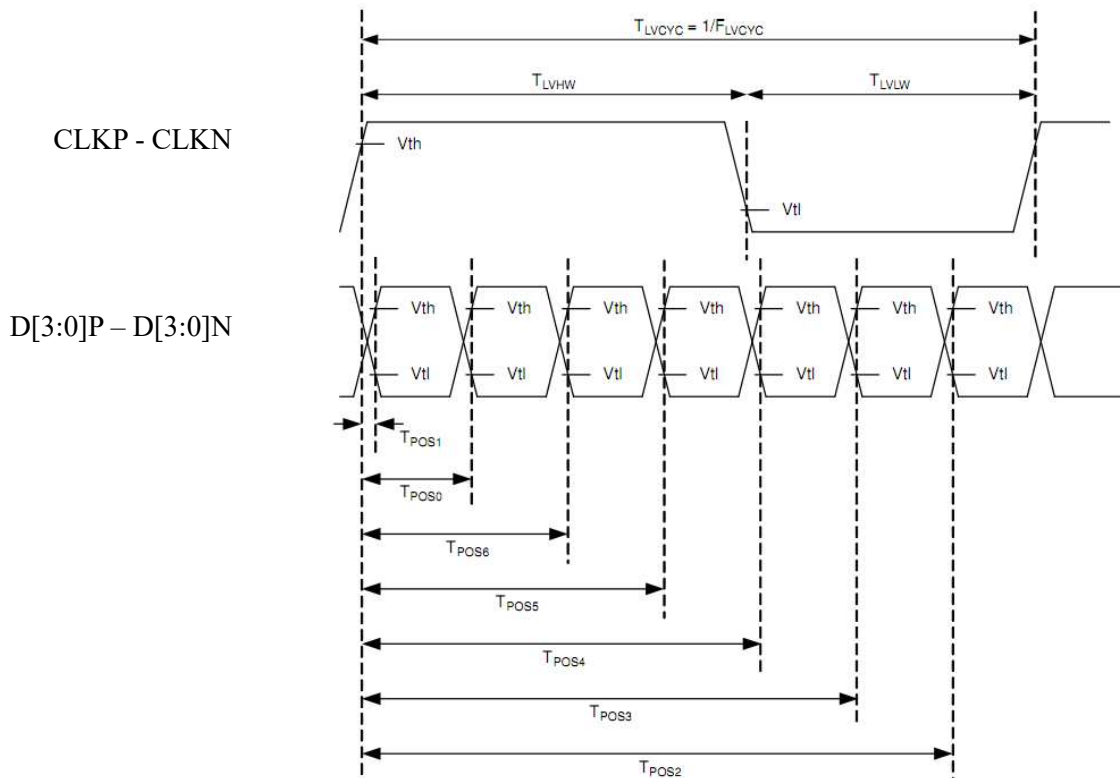

Single End Signals:  
 CLKP/N  
 D[3:0]P/N

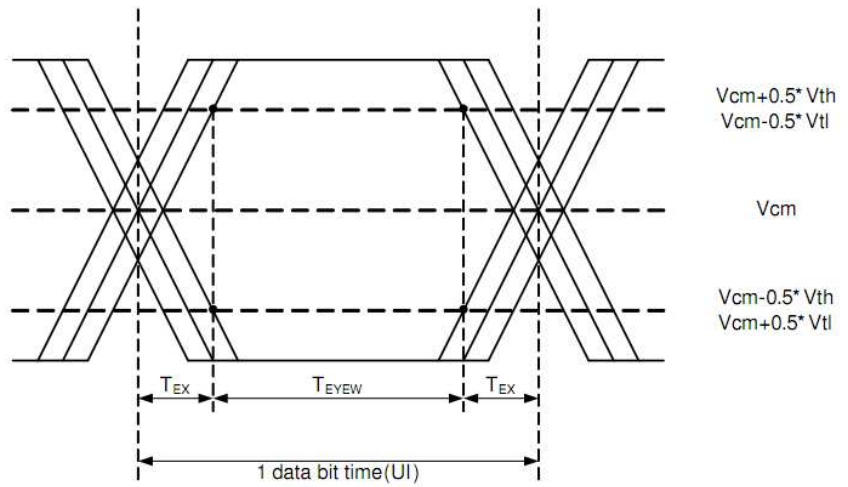

Differential Signals:  
 CLKP - CLKN  
 D[3:0]P - D[3:0]N

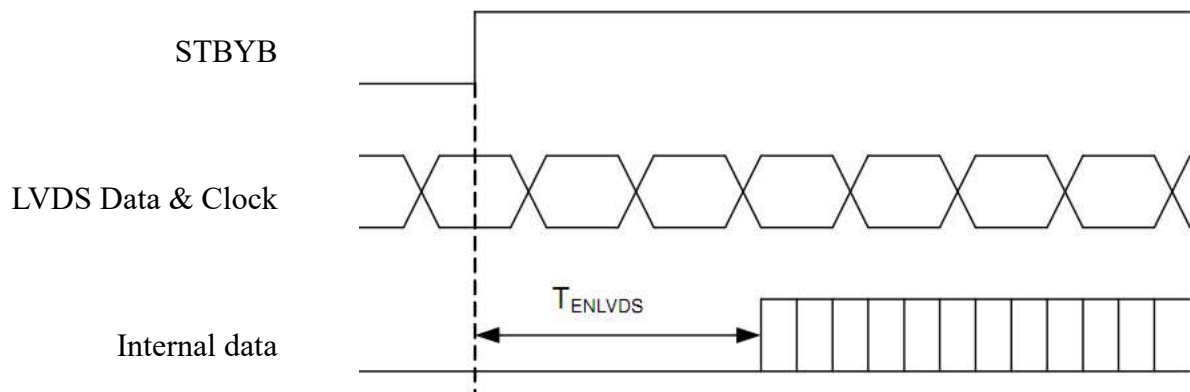
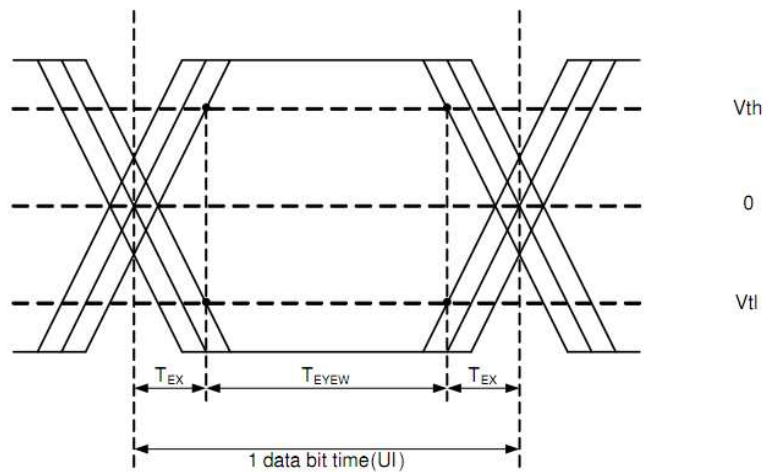

Figure 5: LVDS input timing, eye diagram and wake up time

### 5.3.2 LVDS Input Data Format

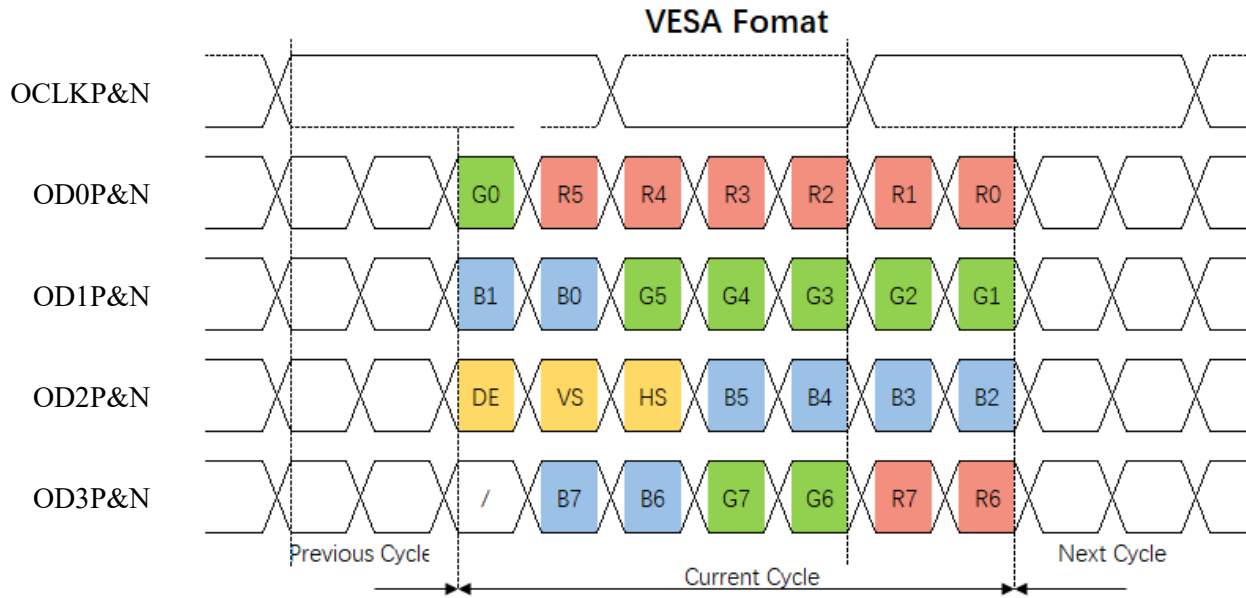

Figure 6: LVDS input data 8bit VESA format

### 5.3.3 Video Signal Timing

**Table 8(a): Video signal timing (DE Mode)**

Parameter	Symbol	Min.	Typ.	Max.	Unit
DCLK frequency	F <sub>DCLK</sub>	25.71	26.7	32.33	MHz
Horizontal valid data	T <sub>HD</sub>	-	800	-	DCLK
1 Horizontal field	T <sub>H</sub>	868	876	920	DCLK
Vertical valid data	T <sub>V</sub>	-	480	-	Line
1 Vertical field	T <sub>V</sub>	502	508	576	Line
Frame Frequency	F <sub>frame</sub>	59	60	61	Hz

**Table 8(b): Video signal timing (HV/SYNC Mode)**

Parameter	Symbol	Min.	Typ.	Max.	Unit
DCLK frequency	F <sub>DCLK</sub>	25.71	26.7	32.33	MHz
Horizontal valid data	T <sub>HD</sub>	-	800	-	DCLK
Hsync pulse width	T <sub>HPW</sub>	12	12	12	DCLK
Hsync back porch	T <sub>HBP</sub>	4	4	4	DCLK
Hsync front porch	T <sub>HFP</sub>	52	60	104	DCLK
1 Horizontal field	T <sub>H</sub>	868	876	920	DCLK
Vertical valid data	T <sub>V</sub>	-	480	-	Line
Vsync pulse width	T <sub>V</sub>	4	4	4	Line
Vsync back porch	T <sub>VBP</sub>	12	12	12	Line
Vsync front porch	T <sub>VFP</sub>	6	12	80	Line
1 Vertical field	T <sub>V</sub>	502	508	576	Line
Frame Frequency	F <sub>frame</sub>	59	60	61	Hz

Note: The TFT module is set to DE mode

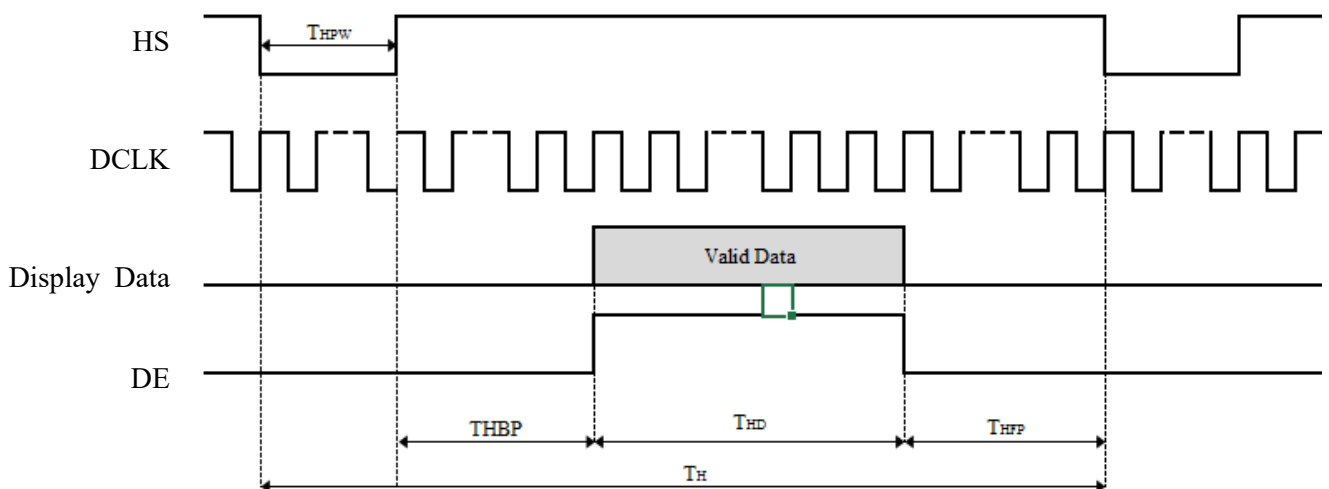

Figure 7.1: Horizontal input timing

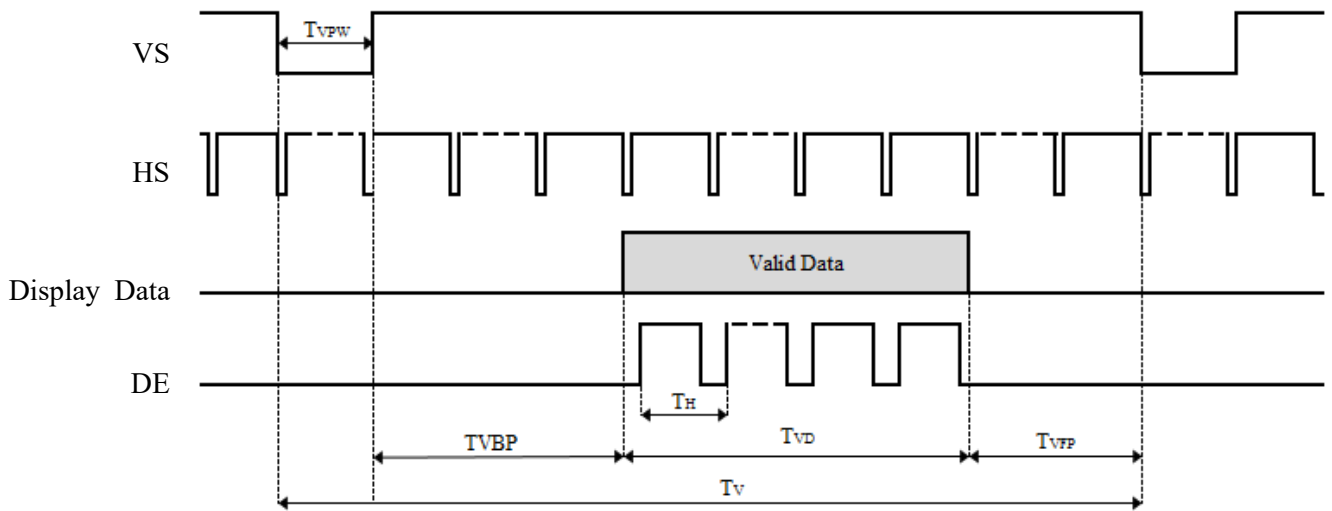

Figure 7.2: Vertical input timing

### 5.3.4 SSC (spread spectrum clock)

The LVDS receiver can support spread spectrum clock, (SSC). Limitation is listed as below.

Table 9

Parameter	Symbol	Conditions	Min.	Typ.	Max.	Unit
Modulation Frequency SSC	SSCMF	LVDS clock frequency center	-	-	100	KHz
Modulation Rate SSC	SSCMR	LVDS clock frequency SSCMR in the range of 15MHz~105Mhz	-	-	+/-3	%

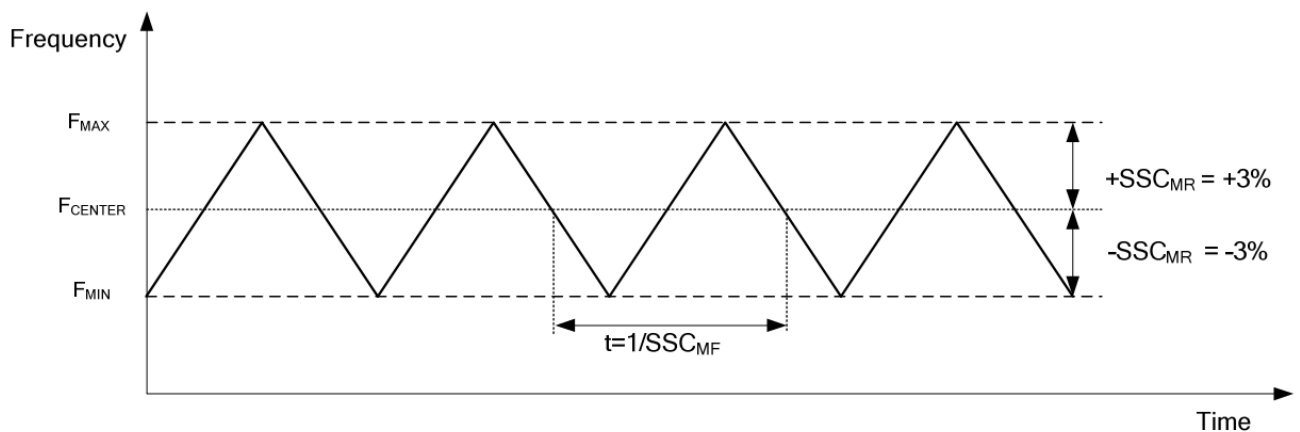

Figure 8

### 5.3.5 SPI interface (3 wires)

SPI interface is used to read and write the setting registers of the TFT module.

All registers setting have been OTP in driver IC.

So no need to using the SPI to initialize module, just pull high SPI pins at customer's system side.

When write register, customer should write the same data to all source driver ICs.

ID and source IC correspond table:

ID	Master
ID[1:0]	0

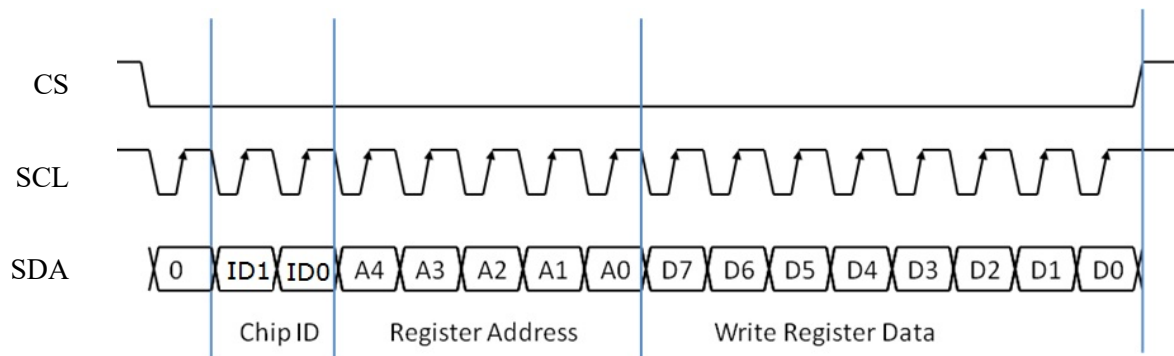

Figure 9(a): SPI write data format

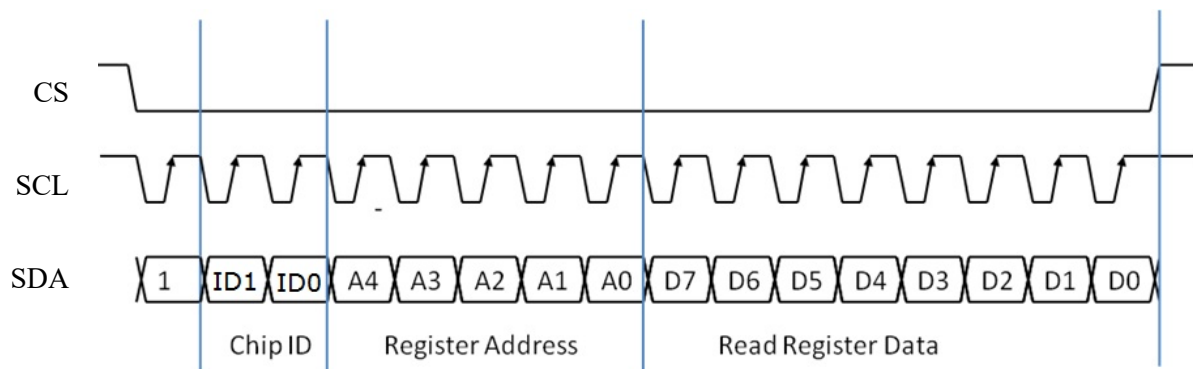

Figure 9(b): SPI read data format

### 5.3.6 SPI interface timing chart

At Ta = 25 °C, VDD=3.3V, GND=0V

Table 10: AC Characteristic of SPI Interface

Parameter	Symbol	Conditions	Min.	Typ.	Max.	Unit
Setup Time	tS0	CS to SCL	60	-	-	ns
	tS1	SDA to SCL	60	-	-	ns
Hold Time	tH0	CS to SCL	60	-	-	ns
	tH1	SDA to SCL	60	-	-	ns
Pulse Width	tW1L	SCL Negative cycle	100	-	-	ns
	tW1H	SCL Positive cycle	100	-	-	ns
	tW2	CS pulse width	1	-	-	us
Clock duty		SCL	40	50	60	%
SCL Frequency		SCL	-	-	5	MHz

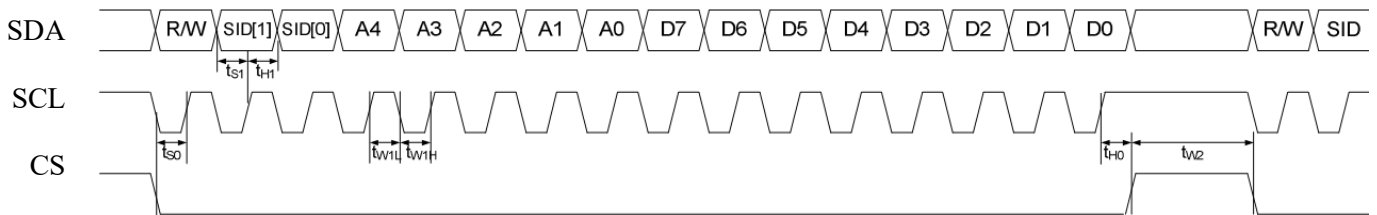

Figure 10: SPI timing

### 5.3.7 Reset Timing

Table 11

Symbol	Parameter	Min.	Typ.	Max.	Unit
tRW	Reset puls width	10	-	-	us
tRT	Reset complete time	-	-	5	us
tNNS	Negative spike noise width	-	-	100	ns

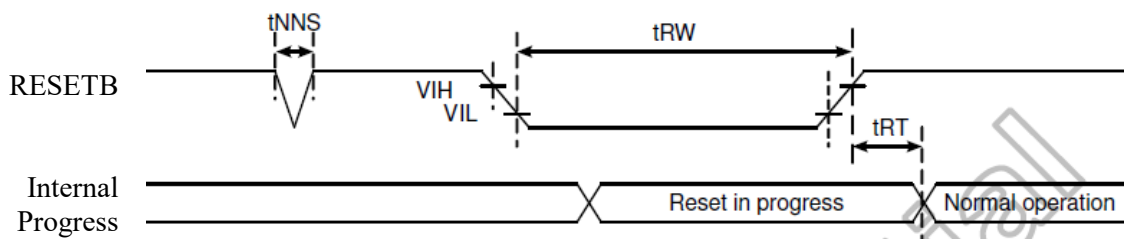

Figure 11: Reset Timing

## 5.4 Power On / Off Sequence

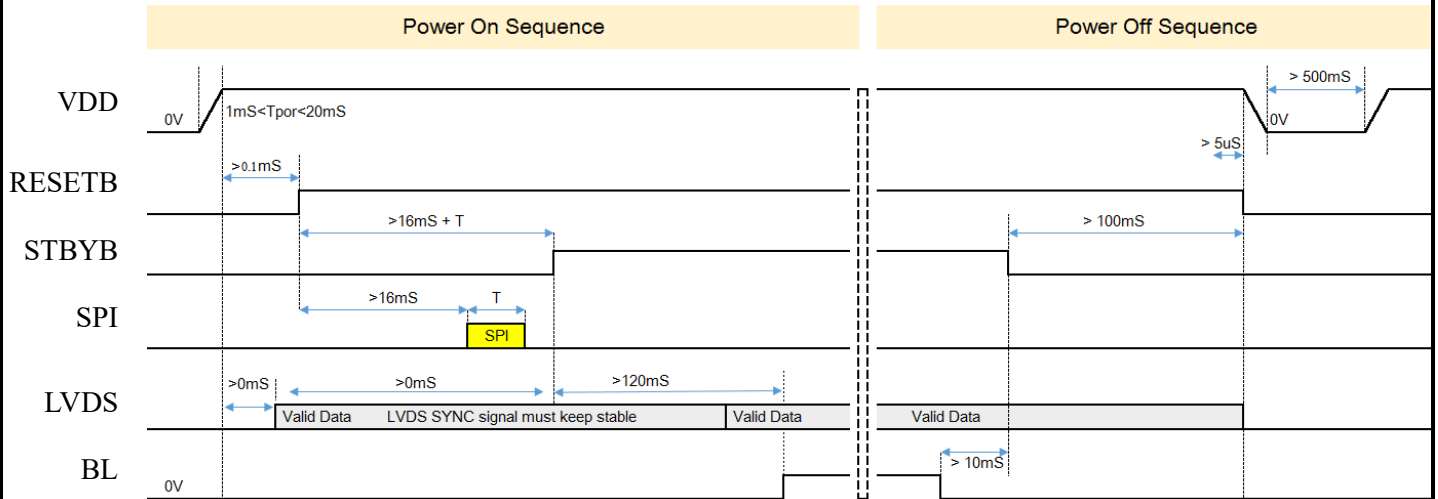

Figure 12: Power on/off sequence

Note1: The rising speed of VDD should be slower than  $1\text{V}/500\mu\text{s}$ .

Note2: Abnormal power on/off sequence, maybe lead to abnormal display or TFT module damage.

Note3: If LVDS signals were out of spec, maybe lead to abnormal display or TFT module damage.

Note4: Video signal should keep stable at display time.

## 5.5 Thermistors Resistance

Table 12: Thermistors Resistance

NCU15XH103F6SRC	
TEMP. (deg. C)	RESISTANCE (k ohm)
-40	195.6520
-35	148.1710
-30	113.3471
-25	87.5588
-20	68.2367
-15	53.6496
-10	42.5062
-5	33.8922
0	27.2186
+5	22.0211
+10	17.9255
+15	14.6735
+20	12.0805
+25	10.0000
+30	8.3145
+35	6.9479
+40	5.8336
+45	4.9169
+50	4.1609
+55	3.535
+60	3.0143
+65	2.5861
+70	2.2275
+75	1.9245
+80	1.6685
+85	1.4521
+90	1.2680
+95	1.1096
+100	0.9738
+105	0.8580
+110	0.7580
+115	0.6715
+120	0.5964
+125	0.5311

## 6. Optical Characteristics

Conditions unless specified otherwise:

- TFT-LCD supply voltage = 3.3 volts
- Elapsed time from switch on is greater than 30 minutes
- RGB, white and black test patterns only
- Factory settings
- Luminance = 100% unless specified
- Measurements are conducted at ambient temperature and perpendicular on module center unless specified

**Table 13: Optical Characteristics**

Parameter	Symbol	Condition		Min.	Typ.	Max.	Unit	Remark		
Contrast Ratio	CR	Viewing angle $\theta=\phi=0^\circ$		1000	1500	-		Note 1,2		
Chromaticity	Red	Viewing angle $\theta=\phi=0^\circ$	$\pm 0.03$	$\pm 0.03$	$\pm 0.03$	-	-	Note 2 (For reference only, the final specifications match the backlight)		
									x	0.555
	y								0.326	
	Green								x	0.339
									y	0.572
	Blue								x	0.156
									y	0.115
	White								x	0.301
									y	0.323
NTSC	NTSC			45	-	%				
Viewing Angle range	Horizontal	$\phi 1$	CR > 10	80	88	-	Deg	Note 3(For reference only, the final specifications match the backlight)		
		$\phi 2$		80	88	-	Deg			
	Vertical	$\theta 1$		80	88	-	Deg			
		$\theta 2$		80	88	-	Deg			
Response Time	Ton+Toff	Viewing angle $\theta=\phi=0^\circ$	Ta=25°C	-	30	45	ms	Note 4		
			Ta=-0°C	-	85	130	ms			
			Ta=-30°C	-	650	980	ms			
Transmittance	T%	Ta=25°C	Viewing angle $\theta=\phi=0^\circ$	7.0	-	-	%	Note 2		
Gamma Value	$\Gamma$	Viewing angle $\theta=\phi=0^\circ$	Ta=25°C	1.9	2.2	2.5		Note 2,5		
Flicker	-	Ta=25°C		-	-	18	%	Note 2,6		
Crosstalk	-	Ta=25°C		-	-	2	%			
Reflector Ratio	-	Ta=25°C	Viewing angle $\theta=\phi=0^\circ$	-	-	6.5	%	@550nm		
White Luminance Uniformity	-	Ta= 25°C	9 points	80	-	-	%	Note 7		
Black Luminance Uniformity	-	Ta= 25°C	9 points	50	-	-	%			

Image sticking	65 degC, 1hr, <Level2, 5 Minutes disappear. Test pattern: 6X8 Chess Board, Inspection pattern : 50% grey	Note2,8
----------------	---	---------

Note 1: Contrast shall be measured at the center of the LCD surface by using DMS or similar equipment. Luminance shall be measured with all pixels set to full white, then to full black state. @Base on BOE backlight.

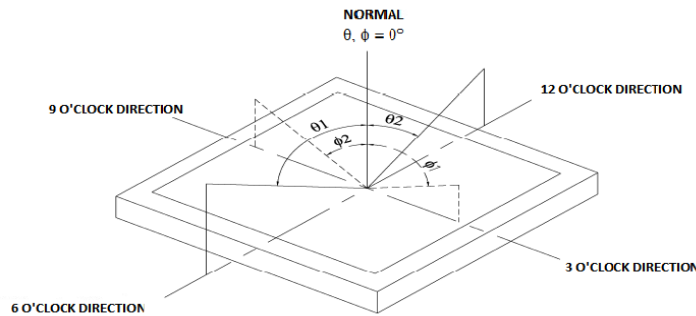

Figure 13: Viewing Definition

Contrast Ratio (CR) is defined mathematically.

$$CR = \frac{\text{Luminance when displaying a white raster}}{\text{Luminance when displaying a black raster}}$$

Note 2: Base on BOE backlight. Side backlight, YAG LED, Optical film structure is two diffusor + one BEF. The measured spectrum of BOE backlight is shown below.

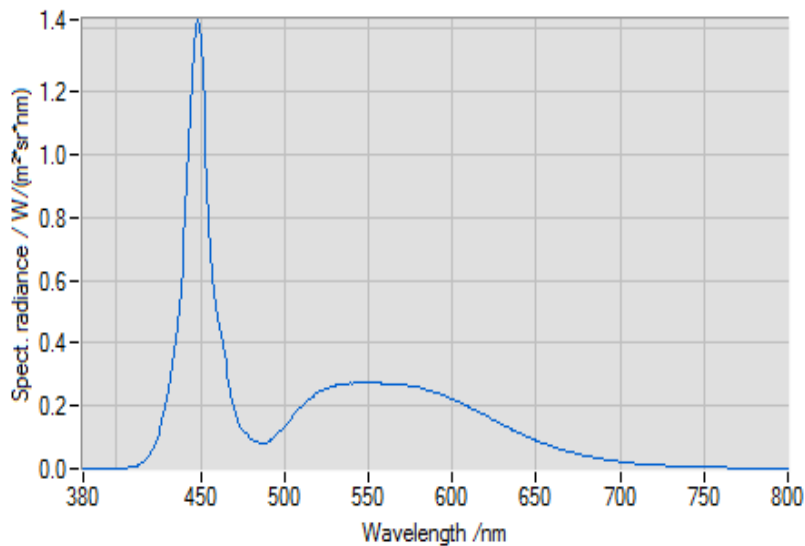

Figure 14: BOE backlight measured spectrogram

Note.3: Viewing angle is the angle at which the contrast ratio is greater than 10. The viewing are determined for the horizontal or 3,9 o'clock direction and the vertical of 6,12.@ Base on BOE backlight.

Note.4: The electro-optical response time measurements shall be made as following FIG. 15 by switching the "data" input signal ON and OFF. The times needed for the luminance to change from 10% to 90% is Tr and 90% to 10% is Tf.

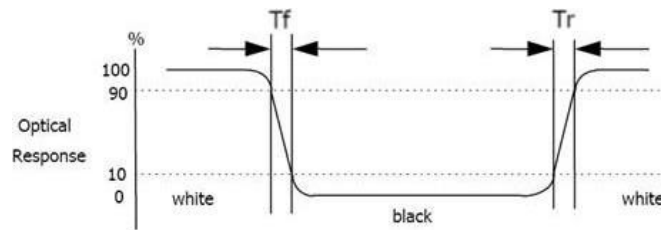

Figure 15: Response time definition

Note 5: Measurement tool and gamma value calculated according to VESA or IDMS standard

Note 6: 1+2 dot inversion pattern

Note 7: 6 Uniformity measurement shall be taken at the locations shown in FIG.16, for a total of the measurements per display, measure surface luminance of these 9 points across the LCD surface with all pixels displaying white@BOE Backlight

The White luminance uniformity on LCD surface is expressed as:

$$\text{Uniformity } \Delta Y = \frac{\text{Minimum Luminance of 9 points}}{\text{Maximum Luminance of 9 points}} \times 100(\%)$$

Figure 16: Transmittance uniformity test method

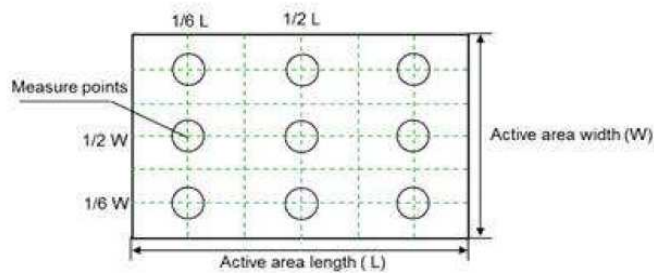

Note 8: 65 degC, 1hr, < Level2, Test pattern: 5X5 Chess Board, Inspection pattern: 50% grey. 5 Minutes  
 Disappear, see FIG 17

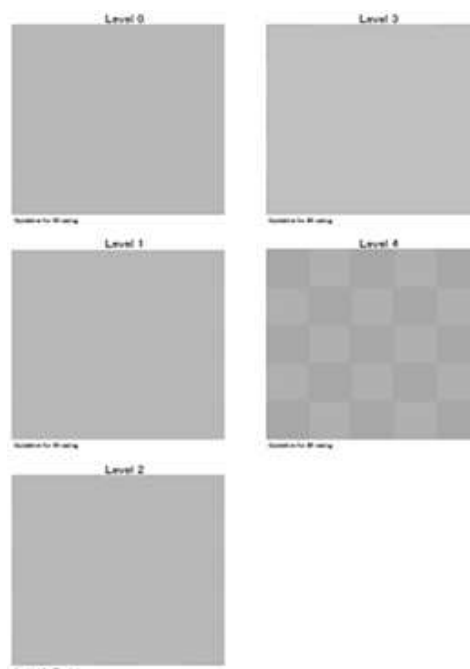

Figure 17: Image Stickin

## 7. Reliability Tests / Environmental

### 7.1 Reliability Test Conditions

Table 14: List of reliability tests

Test	Symbol	Condition	Reference	Sample Qty
1 High Temperature Storage	HST	+105°C / 500 hrs	IEC 60068-2-2 Bb	4pcs
2 Low Temperature Storage	LST	-40°C / 500 hrs	IEC 60068-2-1 Ab	4pcs
3 High Temperature Operating <sup>(Note)</sup>	HOT	+105°C / 500 hrs	IEC 60068-2-2 Bb	4pcs
4 Low Temperature Operating	LOT	-30°C / 500 hrs	IEC 60068-2-1 Ab	4pcs
5 Accelerated Humidity Test Operating	AHTO	+60°C / 90% RH / 500 hrs	IEC60068-2-78 Cab	4pcs
6 Temperature Shock Test	TST	-40°C <math>\diamond</math> +85°C, 30min/5min/30min,200cycles Non-Operating	IEC 60068-2-14Na	4pcs
7 UV exposure resistance	UV	1KW Xenon / 100 hrs Power off.	IEC 60068-2-5 Sa	2pcs

#### Notes:

- The test result shall be evaluated
- After the sample has been left at room temperature and humidity for at least 2 hours without load  
样品在室温及湿度下无负载放置至少 2 小时后，对测试结果进行评估。
- After the reliability test, the product only guarantee function normally without any fatal defects (no display, line defect, abnormal display etc.).  
可靠性测试后，产品仅保证功能正常，无任何致命缺陷（无显示、线缺陷、显示异常等）。
- After completion of the test, when there is no agreement with customer, the sample should be free from the following defects:  
测试完成后，在与客户无协议的情况下，样品应无以下缺陷：
  - Air bubbles in the LCD
  - Seal leakage
  - No display
  - Missing lines
  - glass crack
  - Current consumption increment > 100%
  - Contrast reduction > 40%
  - Luminance reduction > 40%
  - Color coordinates change > 0.05
- Performs backlight de-rating during high temperature operating test.

在高温操作测试期间执行背光降额。

6. Module color change (such as yellowish) will be judged as pass if the color coordinates variation is less than or equal to 0.05.  
如果颜色坐标变化小于或等于 0.05，模块颜色变化（如发黄）将被判定为合格。
7. No sequential tests are guarantee unless the supplier has agreement with customer.  
除非供应商与客户达成协议，否则不保证进行连续测试。
8. Optical performance below  $-30^{\circ}\text{C}$  is not guarantee.  
 $-30^{\circ}\text{C}$  以下的光学性能不保证。
9. The surface protective film is used to protect the surface from being scratched or getting dirty during the product turnover process. The protective film needs to be removed before the reliability test to avoid residue glue or other influences.  
表面保护膜用于保护产品周转过程中的表面不被刮伤或弄脏；可靠性测试前需要去除保护膜，以避免残胶或其他影响。

## 7.2 Electrostatic Discharge (ESD)

Table 15: ESD test conditions

Test	Condition	Method	Remark	Quantity
Human body model	R = $330\Omega$ , C = 150pF, <ul style="list-style-type: none"> <li>• Air discharge: <math>\pm 15\text{KV}</math> to display surface</li> <li>• Contact discharge: <math>\pm 8\text{KV}</math> to metal frame</li> </ul>	IEC61000-4-2	Not operating /Class B	2pcs
Machine model	R = $0\Omega$ , C = 200pF, $\pm 200\text{V}$ to I/O pins	MIL-STD-883, method 3015	Not operating	2pcs

Note 1: The TFT-LCD panel and IC on module are sensitive to electrostatic discharge; please make sure equipments and operators are properly ground before and during handling.

Note 2: As different customer application have different interfacing designs and assembly processes, the display module has no ESD protection circuitry. Customer is required to take special care on ESD level control in the assembly and test processes.

## 8. Inspection Criteria

### 8.1 Inspection Conditions 检查条件

Items 项目	Condition 条件	
Ambient lighting 环境亮度	Cosmetic inspection 500~1000 Lux. function inspection less than 200 Lux. 外观检查 500~1000 Lux. 功能检查小于 200 Lux	
LCD surface luminance LCD 表面亮度	Min 750 cd/m2, Typ 800 cd/m2 for inspection.(Except uniformity test)	
Temperature /Humidity 温度/湿度	21 ± 4°C with 35~80%	
Driving condition 驱动条件	Equipment 设备	Product specific test tool 产品规格书说明的测试工具
	Test pattern 测试画面	Black, White, Red, Green, Blue, etc 黑, 白, 红, 绿, 蓝, 等
	Supply voltage 电源	Typical voltages as given in the specification 规格书提供的典型电压
Inspection method 检查方法	Distance 距离	40 cm ± 10 cm from display 距显示屏40cm ± 10 cm
	Viewing angle 视角	performing in front of the panel All directions for inspecting the sample should be: ADS type: within 45° to perpendicular line.; ADS 产品: 面向 Panel, 所有方向 45°角内 (与垂直线);

## 8.2 Visual Inspection Criteria

Items 项目	Details 详细检查点		Inspection Criteria 检验标准		Type
			A Area	B/C Area	
Dot Defects (function defect) 亚像素缺陷 (功能不良)	Bright dot Defect 亮亚像素缺陷		N≤0		Ignore Major
	Dark dot Defect 暗亚像素缺陷		N≤3		
	Bright + Dark dot Defect 亮+暗亚像素缺陷		N≤3		
	Joint dot Defect(Combining with bright dot standard to judge) 亚像素相连缺陷(结合亮点标准判定)		N≤1		
Line Defects 线缺陷	Bright Line, Dark Line 亮线,暗线 (像素不良导致)		N =0		
Cosmetic defect 外观不良	Foreign material Black/Bright Spot 异物暗点亮点 (Hair, Lint, etc) (头发, 棉绒等)	Circular Type 圆型	Size (大小)	Accepted qty (接受数量)	Ignore Minor
			D≤0.15mm	Ignore	
			0.15mm<D≤0.25mm	N≤4	
	D>0.25mm	N=0			
	Linear Type 线型	W≤0.05mm, Ignore			
		0.05mm<W≤0.1mm, L≤3mm, N≤4			
		W>0.1mm, L>3mm, N=0			
	Dent or bubble 凹痕或气泡	Circular Type 圆型	D≤0.15, Ignore		
			0.15mm<D≤0.25mm, N≤2		
			D>0.25mm, N=0		
Scratch 划痕	Linear Type 线型	W≤0.05mm, Ignore			
		0.05mm<W≤0.1mm, L≤3mm, N≤4			
		W>0.1mm, L>3mm, N=0			
Abnormal display 异常显示	All white 全白	Not allowed 不允许	Ignore Major		
	All black 全黑	Not allowed 不允许			
	Gray scale 灰阶	Not allowed 不允许			
	Abnormal display 异常显示	Not allowed 不允许			
Mura, 不均匀. (Pure black/with pattern check 纯,黑/白画面检查)			Refer to limit sample agreed by both BOEVX and customer or 5%ND Filter, check time less than three seconds, the distance from ND filter to product around 5cm,from ND filter to eye around 30cm~40cm, checking time:3s 参考双方承认极限样品或者在 5% ND 滤片下检查, 检查时间<3s。ND filter 距离产品约 5cm,距离眼睛约 30cm~40cm	Ignore Minor	

Note 1) Definition of the Area 区域定义

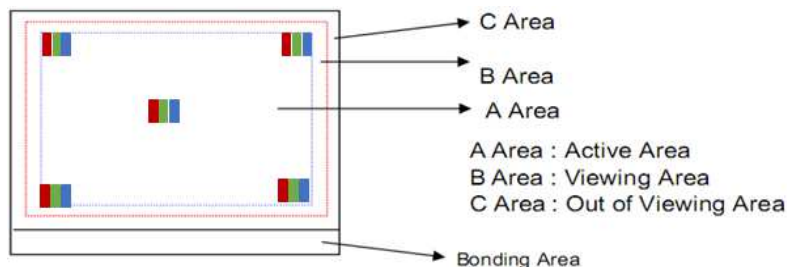

Active Area:有效区域  
 Viewing Area:可视区域  
 Out of Viewing Area: 可视区之外  
 Bonding Area: 邦定区域

Note 2) Protective film scratch/bubble/ surface dirt are not accounted.保护膜划伤/保护膜气泡/表面脏污不计不良

Note 3) D = Diameter (直径), L = Length(长度), W = Width (宽度), N = Number (数量), DS = Distance.

Spot which caused by foreign material(particle) will not be counted the color or the brightness. Spot size will be counted by the actual measurement of the particle. If one particle judged by D or (L,W) is within spec, then this particle will be accepted.

异物暗、异物亮点、斑点等非像素点类缺陷，不计颜色和亮度。大小按异物实际测量计算；若按圆型（D）或线型之一(L、W)的标准判定可接受，则此点缺陷可接受。

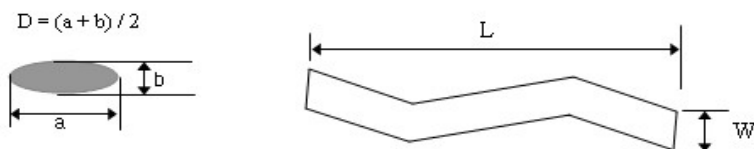

Note 4) [1] 1pixel = 3dots(Dots: sub-pixels 即亚像素). Dot which is invisible through 5%ND filter or smaller than 1/2 of sub-pixel size will not be counted as "1 dot" defect.

5%ND可遮盖或者大小小于1/2亚像素的点不计算为“1点”缺陷.如下图:

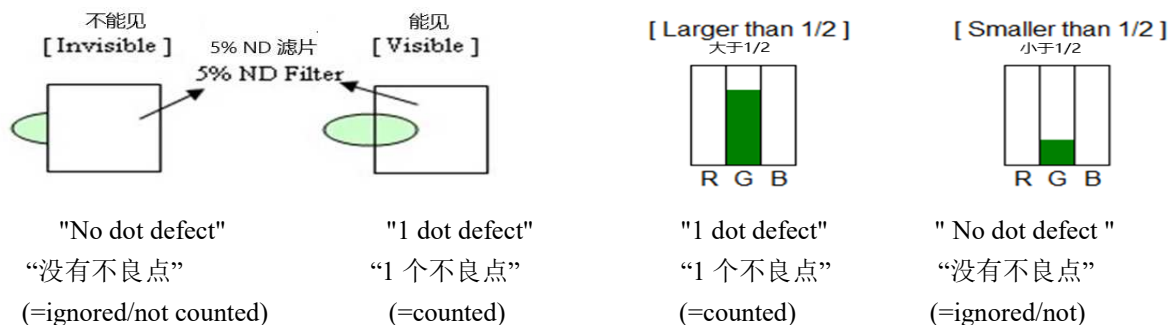

Bright Dot Defects: Dots(sub-pixels) on display which appear bright in the display area at R/G/B.

显示区域显示时在R/G/B画面下可见的亮的像素点 (sub-pixels)

Dark Dot Defects: Dots(sub-pixels) on display which appear dark in the display area at R,G,B Color Pattern.

显示区域显示时在R/G/B画面下可见的暗的像素点 (sub-pixels)

[2] adjacent dots defect]

两个相邻亮子像素缺陷

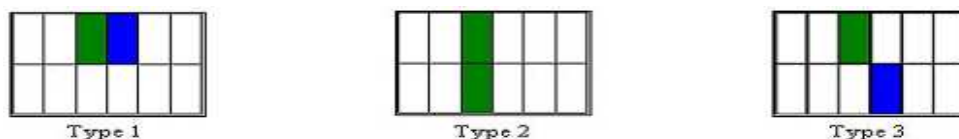





Note 5) Mura: Mura on display which appears darker / brighter against background brightness on parts of display area at

L0/L127/L255

显示区域显示时在 L0/L127/L255 画面可见的发亮程度不均一的现象区域

## 8.3 Appearance Inspection Criteria

### 8.3.1 TFT Panel defects (apply to single cell/FOG/MDL production)

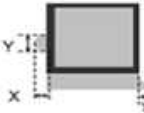
Defects 缺陷		Criteria 标准	Type 类型
Crack 裂纹		Not Allowed 不允许	Major 重要
CF Side Chipping CF 边崩缺		$Y \leq 1/2 \text{ BM}$ X Ignore 忽略 $Z \leq t$	Minor 次要
TFT Side Chipping TFT 边崩缺		$Y \leq 1 \text{ mm}$ X Ignore 忽略 $Z \leq t$	Minor 次要
Corner Chipping 边角崩缺		$X + Y \leq 4 \text{ mm}$ $Z \leq t$	Minor 次要
Burr 毛刺		$X + X1 \leq 0.2 \text{ mm}$ 不影响功能、画面及组装	Minor 次要



Remark:

- \*The above shall not affect the function and assembly 以上均不得影响线路功能及组装
- \* Surface dirt and gelling can be wiped is OK. 表面脏污及黏着可擦拭为 OK
- \* The chipping cannot reach to the perimeter. 崩缺不能进入 TFT 框胶

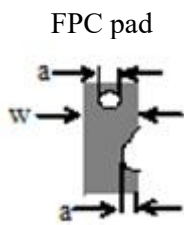
### 8.3.2 FPC defects, FPC 缺陷

Items 项目	Description 描述	Acceptance criteria 验收标准
	Dent, Pinhole, Incomplete, 线路凹痕, 针孔, 不完整	Acceptable if $a \leq w/3$ 如果 $a \leq w/3$ 可接受
	Fold mark 线路折痕	Acceptable if the circuit is not broken 如果金手指线路没断开可接受
	Open circuit 金手指开路	Not Acceptable 不能接受
	Oxidation, Inerasable contamination 金手指氧化、擦不掉的玷污	Not Acceptable 不能接受

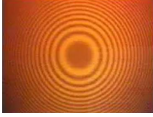
### 8.3.3 Other defect

Items项目	Criteria of acceptance验收模式	Inspection pattern检查模式
Light leakage 漏光	Not visible in 30° viewing cone. 30° 视锥内检查不出来不可见。	Pure white/Pure black 纯白/纯黑
Newton's rings 牛顿环 	D≤5mm,ignore; D>5mm,not allow. D≤5mm,不计; D>5mm,不允许。	Use general cosmetic inspection condition 使用外观检查条件进行检查
Backlight BZ/ metal BZ scratch (No surface treatment) 背光Bezel/Metal Bezel划伤 (无表面处理) 	Finger touch and no touch feeling 裸手指触摸无触感。 (此检查方法有安全风险)	Finger touch 裸手触摸
Ink Printing/ label printing 喷码	Key information can be recognized will be accepted. 关键信息可识别即可接受	Visual inspection 目视
BSR(buzz, squak, rattle noise) and odor 异响及气味	BSR and odor according to BOE internal control standard. 异响及气味标准根据内部标准管控	NA
EMI tape Requirement EMI胶纸 要求	Warp in the range of 90°, non-crimping, warp length does not exceed 3MM, does not affect the function and assembly acceptable 翘起在90°范围内, 不可卷曲, 翘起长度不超3MM, 不影响功能和装配可接受	Visual/measurement 目视/测量
	EMI adhesive paper is not allowed to have obvious damage EMI胶纸不允许有明显破损	Visual inspection 目视
	The edges of EMI adhesive tape need to be aligned with the Mark line. It is not allowed to be pasted off-center or cover the Mark line. EMI胶纸边缘需对齐Mark线, 不允许贴偏或覆盖Mark线	Visual inspection 目视

## 8.4 BOE 客户质量服务流程 ( BOE Customer Quality Service Process )

In order to provide better service to Customer, BOE shall apply the after-sales product quality service process as below

为了提供给客户更好的服务，BOE 应该提供如下的售后产品质量服务过程：

- 8.4.1、According to the P/O from Customer, BOE should deliver required product to the place appointed by Customer. 根据P/O，BOE将产品运送到客户指定地点。
- 8.4.2、Customer will do IQC for the incoming product. 客户要对来料产品做IQC检查。
- 8.4.3、Inspection standard should be provided by BOE, and it will be valid after confirmed by Customer. Inspection and Defects determination should be carried out according to the standard agreed by both Parties. 检查基准由BOE提供，并由客户确认通过，检查手法和不良按双方达成的基准协议确认。
- 8.4.4、Customer should use the LCD product according to the instruction. BOE will not be responsible for the defect product caused by violation of Users' Instruction. 客户使用BOE产品要遵守说明书，对于违反说明书的使用BOE不负责。
- 8.4.5、Both parties should deal with the quality problem with friendly cooperative policy. And both parties should negotiate to deal with the defect products of which the responsibility is not very clear 双方在处理产品质量问题时要遵循友好合作策略，对于责任方归属不明确时，双方要谈判解决。
- 8.4.6、If there is no other signed document, the warranty of the product is 12 months after the production date (the date on the product label). 如无其他签署协议，产品保质期为12个月，从生产日期（即产品label日期）开始算。

## 8.5 The warranty will be avoided 质保期失效:

The warranty will be avoided in cases of below:

在下列情况中，质保期将会失效:

- 8.5.1、When the warranty period is expired. 质保时间超期。
- 8.5.2、When the LCMs were repaired by 3rd party without Supplier's approval. LCM在没有供应商的允许下交由第三方修复。
- 8.5.3、When the LCMs were treated like disassemble and rework by the Customer and/or customer's representatives without Supplier's approval. LCM在没有供应商的允许下，被客户或是客户的代表方拆开或是维修时。
- 8.5.4、Working at abnormal temperatures for a long time 长期在非常温下工作

## 8.6 Service scope on warranty part which confirmed by BOE its responsibility:

质保期内经BOE确认存在质量问题的产品，可提供如下服务：

8.6.1.、 Base on customer request, provide service of repair, or 1to1 replace, or 1to1 credit at its selling price.

“三包服务”：根据客户需求对不良品进行无偿维修、或1对1退换货、或1对1按产品销售单价退款。

8.6.2.、 Base on customer request, BOE could provide the analysis and improvement report. After BOEVX sending out the report 15 working dates, if there is no further comment from customer, the issue will be closed.

根据客户需求提供相关分析改善报告。 BOE提供分析改善报告15个工作日后，若未收到客户进一步反馈，则问题关闭。

8.6.3.、 At any time, if third party or other related service is required for solving quality issue, both BOE and customer should have discussion and reach agreement in advance. Otherwise, BOE have the right to reject any extra cost without it authorization.

任何时候，若因品质问题需BOE提供第三方或者其他相关服务时，双方应提前沟通并协商一致。否则，BOE将拒绝任何未经BOE授权的额外费用。

Remark: Out of warranty period, no further service would be provided including repair, or replace, or credit service etc.

\*备注：对质保期失效产品，BOE不再做相关的质保承诺，且不再提供“三包服务”或者其他相关服务。

## 8.7 Caution For operation 操作注意事项

8.7.1.、 Do not display the fixed pattern for a long time because it may develop image sticking due to the LCM structure. If the screen is displayed with fixed pattern, use a screen saver.

由于LCM结构原因，不能长时间显示一个固定模式，会造成残像；如果屏幕显示为多种模式，请添加一个屏幕保护程序。

8.7.2.、 Static electricity (ESD) will damage the panel,. Please make sure that operators wear static-protective glove effectively and working tables & device are effectively grounded during operation and other ESD protective method.

ESD会损坏Panel，确保作业员在作业过程中佩戴防静电手套，并且在作业过程中工作台和设备要有效接地。

8.7.3.、 The LCD modules use C-MOS LSI drivers, Therefore, it is recommended that customers connect the unused Pin according to the requirements in the Pin Assignment section of the specification. do not input any signals before power is turn on, and ground you body, work assembly area, assembly equipments to protect against static electricity.

液晶模块采用C-MOS LSI驱动，因此建议客户按照规格书Pin Assignment章节要求，连接未使用的Pin，在接通电源之前不要输入任何信号，并将您的身体、工作组装区域、组装设备接地，以防止静电。

- 8.7.4、Please place LCM on the tray provided by BOE while moving it, in order to avoid mechanical damage.

将LCM放在BOE Tray盘中转运，以防止机械损伤。

- 8.7.5、Please keep the LCM in the specified, original packing boxes when storage.

不能将没包装材料覆盖的LCM进行堆积重叠。

- 8.7.6、DO NOT press the area covered with PET or such materials. These are weak point of LCM since of TCPs (Driver ICs) and PWBs.

不要直接用手触摸TCP（驱动IC）、PWB板。

- 8.7.7、Since the LCM is made of glass, do not apply strong mechanical impact or static load onto it.

Handling with care since shock, vibration, and careless handling may seriously affect the product. If it falls from a high place or receives a strong shock, the glass may be broken.

LCM的Panel包括两张薄玻璃，非常容易被损坏，所以在处理LCM时应该极其小心。LCM是由玻璃制造而成，因此表面不能承受住强烈的机械撞击或是静态的压力，在处理时避免撞击、振动。粗心对待会严重影响产品，如果LCM从高处掉落或是受到强烈的撞击，玻璃可能会碎掉。

- 8.7.8、The polarizers on the surface of panel are made from organic substances. Be very careful for chemicals that not to touch the polarizers or it may leads the polarizers to be deteriorated.

Panel表面的偏光片是由有机物构成，所以要避免化学品接触到偏光片，否则会导致偏光片的损坏。

- 8.7.9、Remove the protective film slowly , the speed should not exceed 40mm/s, keeping the removing direction approximate 30-degree not vertical from panel surface, if possible, under ESD control device like ion blower, and the humidity of working room should be kept over 50%RH to reduce the risk of static charge.

撕除LCM保护膜速度要慢，速度不超过40mm/s，角度大约为30°，不要垂直于Panel表面撕膜；可能的话在离子风机下，湿度50%下进行以降低静电风险。

- 8.7.10、Avoid the use work clothing made of synthetic fibers. We recommend cotton clothing or other conductivity-treated fibers.

工作布条应避免使用合成纤维，应使用棉布或是导电纤维布。

- 8.7.11、Avoid any force bending on FPC golden finger area.

FPC 金手指区域避免受力弯折。

- 8.7.12、The electrochemical reaction caused by DC voltage will lead to LCD degradation, so DC drive should be avoided.

直流电压引起的电化学反应会导致LCD劣化，应避免直流驱动。

- 8.7.13、 Do not exceed the absolute maximum rating value. (supply voltage variation, input voltage variation, variation in part contents and environmental temperature, and so on) Otherwise the Module may be damaged.  
不超过绝对最大额定值(电源电压变化、输入电压变化、部件内容变化、环境温度变化等), 否则可能损坏模块。
- 8.7.14、 Design the length of cable to connect between the connector for back-light and the converter as short as possible and the shorter cable shall be connected directly. The longer cable between that of back-light and that of converter may cause the luminance of LED to lower and need a higher startup voltage(Vs).  
背光连接器与转换器之间的电缆长度设计尽量短, 短的电缆应直接连接; 背光和转换器之间的连接线较长, 可能导致LED的亮度降低, 需要更高的启动电压(v)。
- 8.7.15、 Do not connect or disconnect the cable to/ from the module at the "Power On" condition.  
请勿在“上电”状态下连接或断开模块的连接线。
- 8.7.16、 When the module is operating, do not lose CLK, HS,VS signals. If any one these signals is lost, the LCD panel would be damaged.
- 8.7.17、 Follow module power-on and power-off sequence. If wrong sequence is applied, the module would be damaged.  
服从模组上下电时序, 如果应用错误的顺序, 模块将被损坏。
- 8.7.18、 If the product will be used in extreme conditions such as high temperature,high humidity,high altitude, It is strongly recommended to contact manufacturer for application engineering advice.Otherwise, Its reliability and function may not be guaranteed  
如果产品将在高温、高湿、高海拔端条件下使用, 强烈建议联系厂家进行应用工程咨询; 否则, 可能无法保证其可靠性和功能
- 8.7.19、 Be careful for condensation when sudden temperature change occurs. Condensation damages polarizer or electrical contact parts. And after fading condensation, smear or spot will occur.  
当温度突然变化时, 要小心冷凝, 冷凝损坏偏振片或电接触部件, 而褪色后凝结, 则会出现污迹或斑点。

## 9. Packing Specification

CONFIGURATION :  
 MS:MS\_V1\_3.1\_COG-VLBJT207-03\_20250612\_R2

REV.	AMENDMENT	DATE
REV.0	NEW RELEASE	2025.3.18
1	UPDATE THE MS & PALLET DELETL THE MES LABEL	2025.6.17

NO.	ITEM NO.	DESCRIPTION	QTY /BOX	BAAN UNIT	BOX DOSAGE (10PCS)	SIZE
8	LBE-100080-03	CUSTOMER OUTER BOX LABEL	1	PCS	0.062	100X80
7	LBE-102054-01	OUTER BOX LABEL	1	PCS	0.062	102X54
6	LBE-0001-02	INNER BOX LABEL	6	PCS	0.371	102X36
5	CTN-165124161M	OUTER BOX	1	PCS	0.062	420X315X410
4	CTN-155116048F	AIRCRAFT BOX	3	PCS	0.186	395X295X122
3	ESD-236177SA-01	ESD BAG	3	PCS	0.186	600X450
2	PLT-24024TWA-02	PLASTIC TRAY	30	PCS	1.852	390X290X16.7
1	COG-VLBJT207-03	MODULE	162	PCS		81.0X56.9X2.8

PLASTIC TRAY  
 ONE TRAY FOR 6 PCS MODULE  
 ITEM NO.: PLT-24024TWA-02  
 MATERIAL: TRANSPARENT PET T=1.0mm  
 PLASTIC TRAY SIZE: 390(L) X 290(W) X 16.7(H)mm

①MODULE

DISPLAY FACE UPSIDE  
 (显示屏朝上)

INNER BOX

- 6 PCS/TRAY X 9 TRAYS/AIRCRAFT BDX = 54 PCS/AIRCRAFT BDX.
- EMPTY TRAY ADD ON TOP FOR ANTI-STATIC PURPOSE.  
(最上层吸塑盘为空盘)
- EACH TRAY SHOULD BE ROTATED 180°.  
(每层吸塑盘需旋转180度摆放)
- AFTER PUT TRAYS INTO THE ESD BAG, SEAL THE OPEN SIDE BY TRANSPARENT TAPE.  
(将吸塑盘装入ESD袋后,再用透明胶纸封口)
- USING BUBBLE SHEET TO FILL UP THE EMPTY SPACE IF ANY.  
(若有空隙请用泡沫块填充)

⑥ Vx INNER BOX LABEL  
 ITEM NO.: LBE-0001-02  
 (Vx LABEL 标准内容)

OUTER BOX  
 ITEM NO: CTN-165124161M

⑦ Vx OUTER BOX LABEL  
 ITEM NO.: LBE-102054-01  
 (Vx LABEL 标准内容)

⑨ CUSTOMER OUTER BOX LABEL  
 ITEM NO.: LBE-100080-03  
 (贴在小侧面,位置由包装部根据实际来定)

OUTER BOX

⑤ OUTER BOX

54 PCS/AIRCRAFT BOX X 3 AIRCRAFT BOX/OUTER BOX = 162 PCS/OUTER BOX

TITLE: PACKING DRAWING

3 <sup>rd</sup> ANGLE PROJECTION	UNIT	SCALE
	mm	NOT TO SCALE

NAME	SIGN	DATE
DRAWN: XU YAN WEN		
CHECKED: LRIS LI		
APPROVED: NANCY LIU		

**BOE** VARITRONIX LIMITED

MODEL:	REV	DATE
COG-VLBJT207-03	0	2025.3.18
DRAWING NO.:	1	2025.6.17
PD_V1_3.1_COG-VLBJT207-03_20250617_R1	SHEET 1 OF 4	

TRANSPORTATION MODE(运输方式):		△ 12 PAT-12001000DW-1 PALLET		1	PCS	0.002	1200X1000X120
海运/陆运		11 CTN-630002002-01 HARD EDGES		4	PCS	0.008	1620X50X50
		10 CTN-464386039K CARTON COVER		2	PCS	0.004	1190X990X100
NOTE: N/A		1 COG-VLBJT207-03 MODULE		5184	PCS		81.0X56.9X2.8
NO.	ITEM NO.	DESCRIPTION	QTY /PALLET	BAAN UNIT	BOM DOSAGE (10PCS)	SIZE	

PALLET: PAT-12001000DW-1△

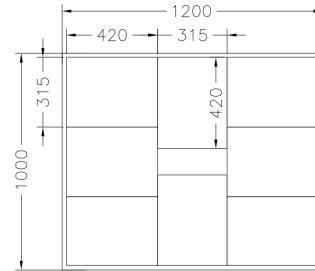

- > 8 BOXES PER LEVEL (每层放8个BOX)
- > 4 LEVEL PER PALLET (每卡板放4层)

6 PCS/TRAY X 9 TRAYS/AIRCRAFT BOX X 3 AIRCRAFT BOX/OUTTER BOX X 8 OUTER BOX/LEVEL X 4 LEVEL/PALLET = 5184 PCS/PALLET.

- PUT THE CARTON COVER ON PALLET, THEN STACK CARTON BOXES ON THE CARTON COVER.  
(把纸盖板放在卡板上面, 再把纸箱放在纸盖板上)
- PUT THE HARD EDGES ON THE FOUR SIDES.  
(把纸护角放在纸箱的四条侧边)

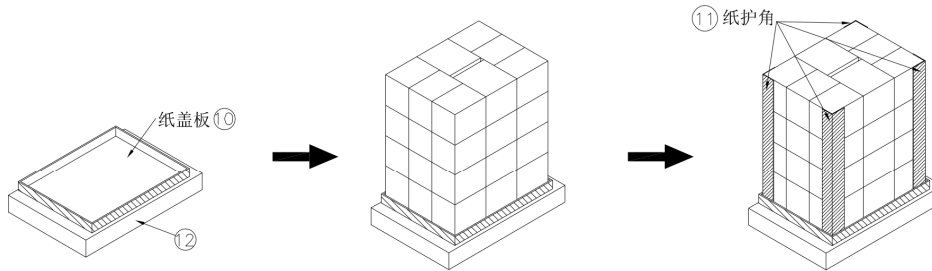

- PUT THE CARTON COVER ON THE CARTON BOX  
(把纸盖板盖在纸箱上面)
- USE THE THIN FILM TO WRAP ALL THE CARTON BOXES.  
(纸箱外面附上薄膜)
- WRAP THE CARTONS BOXES WITH BELTS ON THE PALLET.  
(用打包带将纸箱及卡板包扎好)

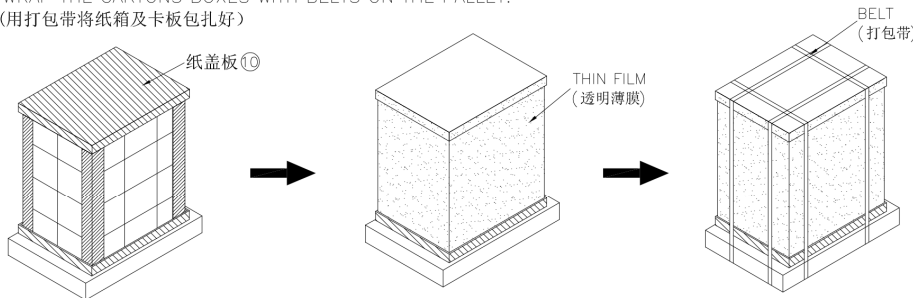

TITLE: PACKING DRAWING	<b>BOE</b>	VARITRONIX LIMITED
MODEL: COG-VLBJT207-03	REV 0	DATE 2025.3.18
DRAWING NO.: PD_V1_3.1_COG-VLBJT207-03_20250617_R1	1	2025.6.17
SHEET 2 OF 4		

### CUSTOMER OUTER BOX LABEL

出货给客户时，外箱需加贴以下标签。标签需在出货前打印，出货数量、料号、客户名称由市场部同事在出货前通知。

- (1) LABEL尺寸：100 X 80 (cm)
- (2) LABEL型号：LBE-100080-03
- (3) LABEL粘贴位置：

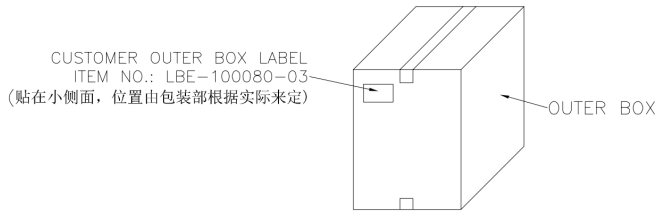

- (4) LABEL格式：

客户名称		RoHS	
料号	XXXXXXXXXX		
物料名称	3.1 TFT		
物料规格	COG-VLBJT207-02		
批次号	LOT NO		
数量	162 pcs	箱号	01/05
生产日期	YYYY/MM/DD		
保质期	24个月		
水晶订单号			
备注			

TITLE: PACKING DRAWING	<b>BOE</b>	VARITRONIX LIMITED
MODEL: COG-VLBJT207-03	REV 0	DATE 2025.3.18
DRAWING NO.: PD_V1_3.1_COG-VLBJT207-03_20250617_R1	1	2025.6.17
SHEET 3 OF 4		

(5) LABEL内容:

描述信息	填写的内容	
	显示规格	内容
供应商名称	宋体, 小五, 粗, 居中	出货前由市场部提供
RoHS	宋体, 小五, 粗, 居中	固定为 RoHS
水晶料号	宋体, 小五, 细, 居中	出货前由市场部提供
物料名称	宋体, 小五, 细, 居中	固定为 3.1 TFT
物料规格	宋体, 小五, 细, 居中	固定为 COG-VLBJT207-02
批次号	宋体, 小五, 细, 居中	和外箱的 LOT 号保持一致
数量	宋体, 小五, 细, 居中	为包装数量, 填写方法为数量+单位
箱号	宋体, 小五, 细, 居中	01/05, 01 为此次出货的箱号, 05 为此次出货的总箱数
生产日期	宋体, 小五, 细, 居中	为包装日期
保质期	宋体, 小五, 细, 居中	固定为 24 个月
水晶订单号	宋体, 小五, 细, 居中	空白
备注		空白







二维码: 二维码的边长需 $\geq 21.5\text{cm}$ , 输入为订单号|供应商代码|物料代码|数量|供应商批次号, 中间用“|”间隔;



- a) 订单号: 空白;
- b) 供应商代码: 空白;
- c) 物料代码: 出货前由市场部提供;
- d) 数量: 为包装数量, 保留6位代码, 前面位数用0替代;
- e) 供应商批次号: 为LOT NO.。

TITLE: PACKING DRAWING	<b>BOE</b>	VARITRONIX LIMITED
MODEL: COG-VLBJT207-03	REV 0	DATE 2025.3.18
DRAWING NO.: PD_V1_3.1_COG-VLBJT207-03_20250617_R1	1	2025.6.17
SHEET 4 OF 4		

## 10. Handling Cautions

### 10.1 Packing Removal and Handling Requirement

Requirement	Wrong	Correct
<p>Get one package each times &amp; hold the package by both hands with proper ESD shielding</p>	 <p>Without ESD gloves and ESD belt</p> <p>Hold the modules by one hand and without proper ESD shielding ( Fail )</p>	 <p>Anti ESD gloves Anti ESD belt</p> <p>Hold the modules by both hands ( Pass )</p>
<p>Prohibit to stack inner package over 3 layers</p>	 <p>Over 3 layers ( Fail )</p>	 <p>Not exceed 3 layers ( Pass )</p>
<p>Total packing tray height must within 40 cm</p>	 <p>packing tray over 40 cm</p> <p>Over 40 cm ( Fail )</p>	 <p>40 CM</p> <p>Lower than 40 cm ( Pass )</p>

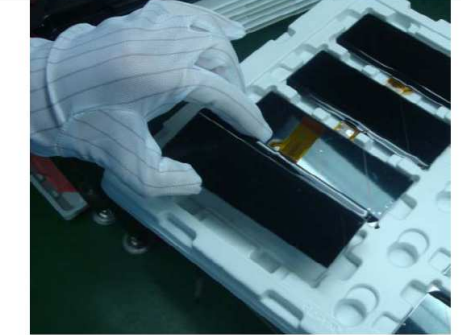
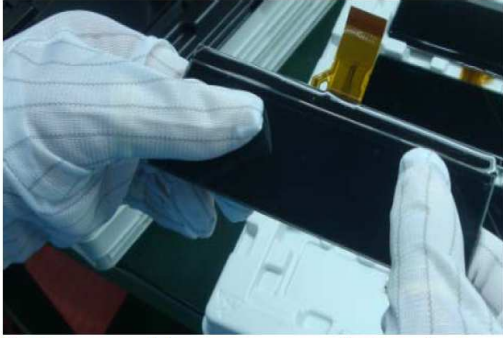
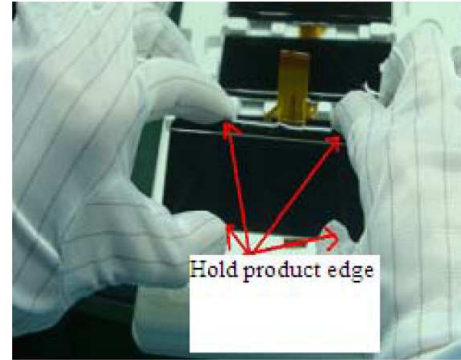
Requirement	Wrong	Correct
<p>Packing tray must rotate 180° in each layer when stack together</p>	 <p>Tray without 180° rotation between each layer</p> <p>Tray without 180° rotation, It will have pressure on the module ( Fail )</p>	 <p>Equal spacing</p> <p>Tray with 180° rotation ( Pass )</p>
<p>Prohibit to touch product surface by fingers</p>	 <p>Fingers can not touch Product surface</p> <p>Hold product and touch its surface ( Fail )</p>	 <p>Hold product edge by hand ( Pass )</p>
<p>During assembly, prohibit to press on product surface by fingers, Must hold the product edges by both hands</p>	 <p>During assembly, press on product surface ( Fail )</p>	 <p>Hold product edge</p> <p>During assembly, use both hands to hold Product edge only ( Pass )</p>

## 10.2 Mounting of module

- Please power off the display module before it is disconnected or connected to the application.
- If the connection to the application is not good, following problems may result.
  1. Significant noise on signals between display module and application
  2. Unstable display performance
  3. Parts on the module will be heat up or damaged
- The LCD module must be handled with care.
- Protective film (Laminator) is applied on surface for protection against scratches and dirt. Please avoid electrostatic charge build-up when peeling off the laminator.

## 10.3 Precautions in Mounting

- When metal part of the LCD module (shielding lid and rear case) is soiled, wipe it with soft dry cloth.
- Wipe off water drops or finger grease immediately when found. Prolonged contact with water may cause discoloration or spots.
- The LCD module contains glass which breaks or cracks easily if dropped or bumped on hard surface. Please handle with care.
- The display and IC on module are sensitive to electrostatic discharge; please make sure equipments and operators are properly ground before and during handling.

## 10.4 Adjusting module

- Adjusting volumes on the rear face of the module have been set to its optimal before shipment. Therefore, do not change any adjusted values. If adjusted values are changed, the display may not perform to specification.

## 10.5 Others

- Do not expose the module to direct sunlight or intensive ultraviolet rays for prolonged hours
- Store the module at room temperature condition.
- If LCD panel breaks, liquid crystal may escape from the panel. Avoid bringing it to eyes or mouth contact. When liquid crystal sticks on hands, clothes or feet, wash it out immediately with soap.
- Observe all other precautionary requirements as in handling general electronic components.
- Please adjust the voltage of common electrode as materials of attachment by 1 module.
- Do not expose the display module to harmful gases such as acid and alkali gasses, which will corrode electronic components.
- Do not disassemble the display module because it can cause permanent damage and will void the warranty agreement.

## 11. Definitions

<b>Data sheet status</b>	
Objective Specification	This data sheet contains target or goal specifications for product development.
Preliminary Specification	This data sheet contains preliminary data; supplementary data may be published later.
Product Specification	This data sheet contains final product specification.
<b>Limiting values</b>	
Limiting values given are in accordance with the Absolute Maximum Rating. Stress above one or more of the limiting values may cause permanent damage to the device. These are stress ratings only and operating of the device at these or any other conditions above those given in the Characteristics sections of the specification is not implied. Expose to limiting values for extended periods may affect device reliability. Device is functional within the limiting conditions doesn't imply the same performance over the covered conditions, customer is required to decide the best range for the final applications.	

## 12. Life Support Applications

These products are not designed for use in life saving appliances, devices or systems where malfunctioning of these products can reasonably be expected to result in personal injury. Customers using or selling these products for use in such applications do so at their own risk and agree full non liability of Varitronix Limited for any damages or losses resulting from such improper use or sale.

## 13. Appendix

“BOE Varitronix Limited reserves the right to change this specification.”

Tel: (852) 2197-6000

Fax: (852) 2343-9555

URL: <http://www.boevx.com>

- END -