



AUO Display+

Product Specification

G215HAN02.0

- Preliminary Specification
- Final Specification

Module	21.5 Inch Color TFT-LCD
Model Name	G215HAN02.0

Company	
Checked & Approved by	Date
_____	_____

Approved by	Date
Elsie Kuo	2025/9/30
Prepared by	
Jenny Hsu	2025/9/30
General Display Business Unit / AUO Display Plus Corporation	

Contents

1.0 Handling Precautions	4
2.0 General Description	5
2.1 Display Characteristics	5
2.2 Optical Characteristics	6
3.0 Functional Block Diagram	9
4.0 Absolute Maximum Ratings	10
4.1 TFT LCD Module	10
4.2 Absolute Ratings of Environment	10
5.0 Electrical characteristics	11
5.1 TFT LCD Module	11
5.1.1 Power Specification	11
5.1.2 Signal Electrical Characteristics	12
5.2 Backlight Unit	13
6.0 Signal Characteristic	14
6.1 Pixel Format Image	14
6.2 The input data format	15
6.3 Signal Description	16
6.4 Timing Characteristics	18
6.5 Timing diagram	19
6.6 Power ON/OFF Sequence	20
7.0 Connector & Pin Assignment	21
7.1 TFT LCD Module	21
7.2 LED Backlight Unit: LED Driver Connector	22
7.3 LED Driver Connector Pin Assignment	22
8.0 Reliability Test	23
9.0 Shipping Label & Packaging	24
9.1 Shipping Label	24
9.2 Packaging	25
10.0 Mechanical Characteristics	26
11 Safety	28
11.1 Keen Edge Requirements	28
11.2 Materials	28
11.3 Capacitors	28
11.4 International Safety Standard Compliance	28

Record of Revision

Version & Date	Page	Old description	New Description																																																																																																																																																																																																						
0.1 / 2025/7/25			Preliminary Specification																																																																																																																																																																																																						
1.0 / 2025/9/30			Final Specification																																																																																																																																																																																																						
	6	<p>2.2 Optical Characteristics The optical characteristics are measured under stable conditions at 25 °C.</p> <table border="1"> <thead> <tr> <th>Item</th> <th>Unit</th> <th>Conditions</th> <th>Min.</th> <th>Typ.</th> <th>Max.</th> <th>Note</th> </tr> </thead> <tbody> <tr> <td rowspan="2">Viewing Angle</td> <td rowspan="2">[degree]</td> <td>Horizontal (Right) CR >10 (Left)</td> <td>89</td> <td>89</td> <td>89</td> <td rowspan="2">2</td> </tr> <tr> <td>Vertical (Up) CR >10 (Down)</td> <td>89</td> <td>89</td> <td>89</td> </tr> <tr> <td>Contrast ratio</td> <td></td> <td>Normal Direction</td> <td>600</td> <td>1000</td> <td></td> <td>3</td> </tr> <tr> <td rowspan="3">Response Time</td> <td rowspan="3">[msec]</td> <td>Raising Time (Tr)</td> <td></td> <td></td> <td></td> <td rowspan="3">4</td> </tr> <tr> <td>Falling Time (Tf)</td> <td></td> <td></td> <td></td> </tr> <tr> <td>Raising + Falling</td> <td></td> <td>25</td> <td></td> </tr> <tr> <td rowspan="5">Color / Chromaticity Coordinates (CIE)</td> <td rowspan="5"></td> <td>Red x</td> <td>TBD</td> <td>TBD</td> <td>TBD</td> <td rowspan="5">5</td> </tr> <tr> <td>Red y</td> <td>TBD</td> <td>TBD</td> <td>TBD</td> </tr> <tr> <td>Green x</td> <td>TBD</td> <td>TBD</td> <td>TBD</td> </tr> <tr> <td>Green y</td> <td>TBD</td> <td>TBD</td> <td>TBD</td> </tr> <tr> <td>Blue x</td> <td>TBD</td> <td>TBD</td> <td>TBD</td> </tr> <tr> <td rowspan="3">Color Coordinates (CIE) White</td> <td rowspan="3"></td> <td>White x</td> <td>0.263</td> <td>0.313</td> <td>0.363</td> <td rowspan="3"></td> </tr> <tr> <td>White y</td> <td>0.279</td> <td>0.329</td> <td>0.379</td> </tr> <tr> <td></td> <td></td> <td></td> <td></td> </tr> <tr> <td>Central Luminance</td> <td>[cd/m²]</td> <td></td> <td>400</td> <td>500</td> <td></td> <td>6</td> </tr> <tr> <td>Luminance Uniformity</td> <td>[%]</td> <td></td> <td>75</td> <td>80</td> <td></td> <td>7</td> </tr> <tr> <td>Color Gamut</td> <td>[%]</td> <td></td> <td></td> <td>72</td> <td></td> <td></td> </tr> </tbody> </table>	Item	Unit	Conditions	Min.	Typ.	Max.	Note	Viewing Angle	[degree]	Horizontal (Right) CR >10 (Left)	89	89	89	2	Vertical (Up) CR >10 (Down)	89	89	89	Contrast ratio		Normal Direction	600	1000		3	Response Time	[msec]	Raising Time (Tr)				4	Falling Time (Tf)				Raising + Falling		25		Color / Chromaticity Coordinates (CIE)		Red x	TBD	TBD	TBD	5	Red y	TBD	TBD	TBD	Green x	TBD	TBD	TBD	Green y	TBD	TBD	TBD	Blue x	TBD	TBD	TBD	Color Coordinates (CIE) White		White x	0.263	0.313	0.363		White y	0.279	0.329	0.379					Central Luminance	[cd/m ²]		400	500		6	Luminance Uniformity	[%]		75	80		7	Color Gamut	[%]			72			<p>2.2 Optical Characteristics The optical characteristics are measured under stable conditions at 25 °C.</p> <table border="1"> <thead> <tr> <th>Item</th> <th>Unit</th> <th>Conditions</th> <th>Min.</th> <th>Typ.</th> <th>Max.</th> <th>Note</th> </tr> </thead> <tbody> <tr> <td rowspan="2">Viewing Angle</td> <td rowspan="2">[degree]</td> <td>Horizontal (Right) CR >10 (Left)</td> <td>89</td> <td>89</td> <td>89</td> <td rowspan="2">2</td> </tr> <tr> <td>Vertical (Up) CR >10 (Down)</td> <td>89</td> <td>89</td> <td>89</td> </tr> <tr> <td>Contrast ratio</td> <td></td> <td>Normal Direction</td> <td>600</td> <td>1000</td> <td></td> <td>3</td> </tr> <tr> <td rowspan="3">Response Time</td> <td rowspan="3">[msec]</td> <td>Raising Time (Tr)</td> <td></td> <td></td> <td></td> <td rowspan="3">4</td> </tr> <tr> <td>Falling Time (Tf)</td> <td></td> <td></td> <td></td> </tr> <tr> <td>Raising + Falling</td> <td></td> <td>25</td> <td></td> </tr> <tr> <td rowspan="5">Color / Chromaticity Coordinates (CIE)</td> <td rowspan="5"></td> <td>Red x</td> <td>0.592</td> <td>0.642</td> <td>0.692</td> <td rowspan="5">5</td> </tr> <tr> <td>Red y</td> <td>0.288</td> <td>0.338</td> <td>0.388</td> </tr> <tr> <td>Green x</td> <td>0.271</td> <td>0.321</td> <td>0.371</td> </tr> <tr> <td>Green y</td> <td>0.571</td> <td>0.621</td> <td>0.671</td> </tr> <tr> <td>Blue x</td> <td>0.161</td> <td>0.151</td> <td>0.201</td> </tr> <tr> <td rowspan="3">Color Coordinates (CIE) White</td> <td rowspan="3"></td> <td>White x</td> <td>0.263</td> <td>0.313</td> <td>0.363</td> <td rowspan="3"></td> </tr> <tr> <td>White y</td> <td>0.279</td> <td>0.329</td> <td>0.379</td> </tr> <tr> <td></td> <td></td> <td></td> <td></td> </tr> <tr> <td>Central Luminance</td> <td>[cd/m²]</td> <td></td> <td>400</td> <td>500</td> <td></td> <td>6</td> </tr> <tr> <td>Luminance Uniformity</td> <td>[%]</td> <td></td> <td>75</td> <td>80</td> <td></td> <td>7</td> </tr> <tr> <td>Color Gamut</td> <td>[%]</td> <td></td> <td></td> <td>72</td> <td></td> <td></td> </tr> </tbody> </table>	Item	Unit	Conditions	Min.	Typ.	Max.	Note	Viewing Angle	[degree]	Horizontal (Right) CR >10 (Left)	89	89	89	2	Vertical (Up) CR >10 (Down)	89	89	89	Contrast ratio		Normal Direction	600	1000		3	Response Time	[msec]	Raising Time (Tr)				4	Falling Time (Tf)				Raising + Falling		25		Color / Chromaticity Coordinates (CIE)		Red x	0.592	0.642	0.692	5	Red y	0.288	0.338	0.388	Green x	0.271	0.321	0.371	Green y	0.571	0.621	0.671	Blue x	0.161	0.151	0.201	Color Coordinates (CIE) White		White x	0.263	0.313	0.363		White y	0.279	0.329	0.379					Central Luminance	[cd/m ²]		400	500		6	Luminance Uniformity	[%]		75	80		7	Color Gamut	[%]			72		
Item	Unit	Conditions	Min.	Typ.	Max.	Note																																																																																																																																																																																																			
Viewing Angle	[degree]	Horizontal (Right) CR >10 (Left)	89	89	89	2																																																																																																																																																																																																			
		Vertical (Up) CR >10 (Down)	89	89	89																																																																																																																																																																																																				
Contrast ratio		Normal Direction	600	1000		3																																																																																																																																																																																																			
Response Time	[msec]	Raising Time (Tr)				4																																																																																																																																																																																																			
		Falling Time (Tf)																																																																																																																																																																																																							
		Raising + Falling		25																																																																																																																																																																																																					
Color / Chromaticity Coordinates (CIE)		Red x	TBD	TBD	TBD	5																																																																																																																																																																																																			
		Red y	TBD	TBD	TBD																																																																																																																																																																																																				
		Green x	TBD	TBD	TBD																																																																																																																																																																																																				
		Green y	TBD	TBD	TBD																																																																																																																																																																																																				
		Blue x	TBD	TBD	TBD																																																																																																																																																																																																				
Color Coordinates (CIE) White		White x	0.263	0.313	0.363																																																																																																																																																																																																				
		White y	0.279	0.329	0.379																																																																																																																																																																																																				
Central Luminance	[cd/m ²]		400	500		6																																																																																																																																																																																																			
Luminance Uniformity	[%]		75	80		7																																																																																																																																																																																																			
Color Gamut	[%]			72																																																																																																																																																																																																					
Item	Unit	Conditions	Min.	Typ.	Max.	Note																																																																																																																																																																																																			
Viewing Angle	[degree]	Horizontal (Right) CR >10 (Left)	89	89	89	2																																																																																																																																																																																																			
		Vertical (Up) CR >10 (Down)	89	89	89																																																																																																																																																																																																				
Contrast ratio		Normal Direction	600	1000		3																																																																																																																																																																																																			
Response Time	[msec]	Raising Time (Tr)				4																																																																																																																																																																																																			
		Falling Time (Tf)																																																																																																																																																																																																							
		Raising + Falling		25																																																																																																																																																																																																					
Color / Chromaticity Coordinates (CIE)		Red x	0.592	0.642	0.692	5																																																																																																																																																																																																			
		Red y	0.288	0.338	0.388																																																																																																																																																																																																				
		Green x	0.271	0.321	0.371																																																																																																																																																																																																				
		Green y	0.571	0.621	0.671																																																																																																																																																																																																				
		Blue x	0.161	0.151	0.201																																																																																																																																																																																																				
Color Coordinates (CIE) White		White x	0.263	0.313	0.363																																																																																																																																																																																																				
		White y	0.279	0.329	0.379																																																																																																																																																																																																				
Central Luminance	[cd/m ²]		400	500		6																																																																																																																																																																																																			
Luminance Uniformity	[%]		75	80		7																																																																																																																																																																																																			
Color Gamut	[%]			72																																																																																																																																																																																																					
	12	<p>Note 1: LVDS Signal Waveform</p>	<p>Note 1: LVDS Signal Waveform</p> <p>Single-End</p> <p>Differential Signal</p>																																																																																																																																																																																																						
	25	<p>Place 4pcs 50g electrical on let top empty trap.</p> <p>1 tray for 1 pcs Panel</p> <p>1 set for 3+1 pcs trays = 5pcs panels</p> <p>5 Layers for ARIS = 10 Gamma = 50PCS TP</p> <p>Palte Dim.: 1150x460x13mm</p>	<p>PET tray</p> <p>EPE Spacer</p> <p>Top tray</p> <p>PP Board</p> <p>All TRAY put into ESD bag and close by tape.</p>																																																																																																																																																																																																						

1.0 Handling Precautions

- 1) Since front polarizer is easily damaged, pay attention not to scratch it.
- 2) Be sure to turn off power supply when inserting or disconnecting from input connector.
- 3) Wipe off water drop immediately. Long contact with water may cause discoloration or spots.
- 4) When the panel surface is soiled, wipe it with absorbent cotton or other soft cloth.
- 5) Since the panel is made of glass, it may break or crack if dropped or bumped on hard surface.
- 6) Since CMOS LSI is used in this module, take care of static electricity and insure human earth when handling.
- 7) Do not open or modify the Module Assembly.
- 8) Do not press the reflector sheet at the back of the module to any directions.
- 9) In case if a Module has to be put back into the packing container slot after it was taken out from the container, do not press the center of LED lightbar edge. Instead, press at the far ends of the LED light bar edge softly. Otherwise the TFT Module may be damaged.
- 10) At the insertion or removal of the Signal Interface Connector, be sure not to rotate nor tilt the Interface Connector of the TFT Module.
- 11) After installation of the TFT Module into an enclosure, do not twist nor bend the TFT Module even momentarily. While designing the enclosure, it should be taken into consideration that no bending/twisting forces are applied to the TFT Module from outside. Otherwise the TFT Module may be damaged.
- 12) Small amount of materials having no flammability grade is used in the LCD module. The LCD module should be supplied by power complied with requirements of Limited Power Source (IEC60950-1 or UL60950-1), or be applied exemption.



AUO Display+

2.0 General Description

This specification applies to the 21.5 inch-wide Color AHVA (IPS-like) TFT-LCD Module G215HAN02.0 The display supports the FHD [1920(H) x 1080(V)] screen format and 16.7M colors

(True 8 bit). All input signals are LVDS interface compatible.

2.1 Display Characteristics

The following items are characteristics summary on the table under 25°C condition:

ITEMS	Unit	SPECIFICATIONS
Screen Diagonal	[mm]	546.86 (21.5")
Active Area	[mm]	476.064 (H) x 267.786 (V)
Pixels H x V		1920(x3) x 1080
Pixel Pitch	[um]	247.95 (per one triad) x247.95
Pixel Arrangement		R.G.B. Vertical Stripe
Display Mode		AHVA Mode, Normally Black
White Luminance (Center)	[cd/m ²]	500 cd/m ² (Typ.)
Contrast Ratio		1000 (Typ.)
Optical Response Time	[msec]	25 (Typ.)
Nominal Input Voltage VDD	[Volt]	5 V (Typ)
Power Consumption (VDD line + LED line)	[Watt]	19.78 W Cell 2.5 W(Typ.) · LED 17.28W(Typ.) VDD= 5.0V, All White Pattern At 60Hz
Weight	[Grams]	1693(typ)
Physical Size	[mm]	497.6(H) x 292.2(V) x 16.6 (D)Typ
Electrical Interface		Dual LVDS
Support Color		16.7M colors, True 8 bit
Surface Treatment		Anti-Glare, 3H
RoHS Compliance		RoHS Compliance
Temperature Range		
Operating	[°C]	-20~70
Storage (Shipping)	[°C]	-20~70



AUO Display+

2.2 Optical Characteristics

The optical characteristics are measured under stable conditions at 25 °C:

Item	Unit	Conditions	Min.	Typ.	Max.	Note
Viewing Angle	[degree]	Horizontal (Right) CR >10 (Left)		89 89	- -	2
		Vertical (Up) CR > 10 (Down)		89 89	- -	
Contrast ratio		Normal Direction	600	1000	-	3
Response Time	[msec]	Raising Time (T _{RR})				4
		Falling Time (T _{RF})				
		Raising + Falling		25		
Color / Chromaticity Coordinates (CIE)		Red x	0.592	0.642	0.692	5
		Red y	0.288	0.338	0.388	
		Green x	0.271	0.321	0.371	
		Green y	0.571	0.621	0.671	
		Blue x	0.101	0.151	0.201	
		Blue y	0.005	0.055	0.105	
Color Coordinates (CIE) White		White x	0.263	0.313	0.363	
		White y	0.279	0.329	0.379	
Central Luminance	[cd/m ²]		400	500		6
Luminance Uniformity	[%]		75	80		7
Color Gamut	[%]			72		

AUO Display+

Note 1: Measurement method

The LCD module should be stabilized at given temperature for 30 minutes to avoid abrupt temperature change during measuring (at surface 35°C). In order to stabilize the luminance, the measurement should be executed after lighting Backlight for 30 minutes in a stable, windless and dark room.

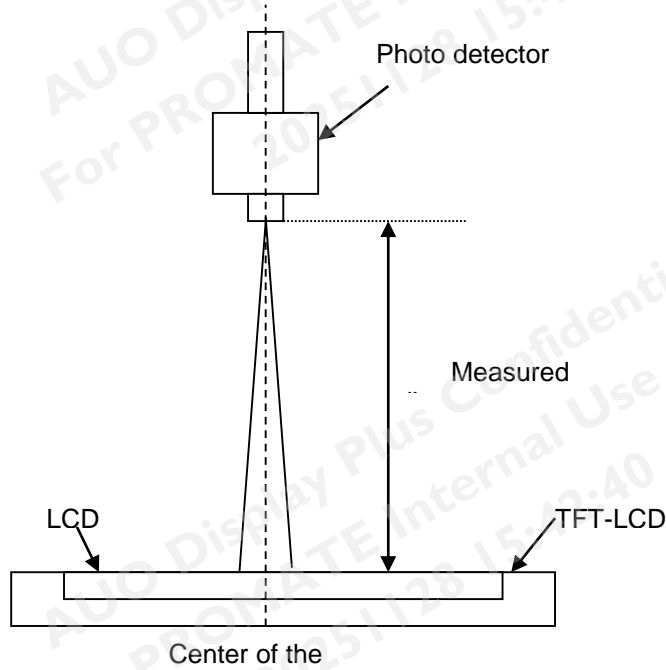

Note 2: Definition of viewing angle measured by ELDIM (EZContrast 88)

Viewing angle is the measurement of contrast ratio ≥ 10 , at the screen center, over a 180° horizontal and 180° vertical range (off-normal viewing angles). The 180° viewing angle range is broken down as follows; 90° (θ) horizontal left and right and 90° (Φ) vertical, high (up) and low (down). The measurement direction is typically perpendicular to the display surface with the screen rotated about its center to develop the desired measurement viewing angle.

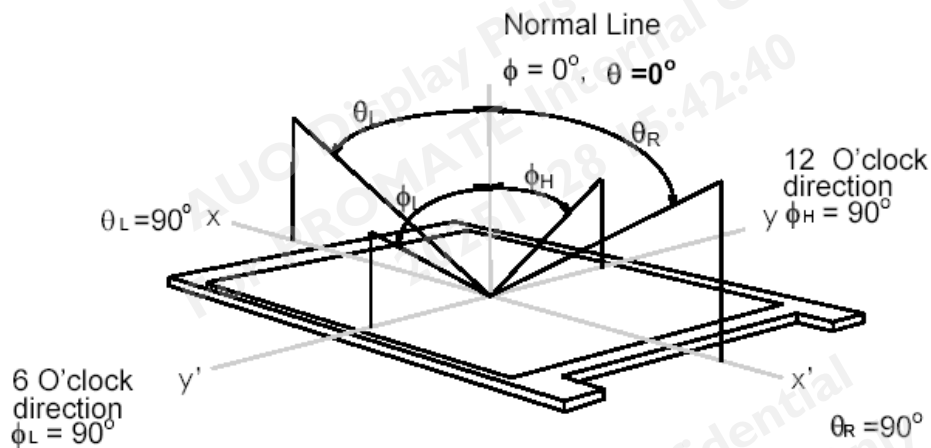

Note 3: Contrast ratio is measured by TOPCON SR-3

Note 4: Definition of Response time measured by Westar TRD-100A

The output signals of photo detector are measured when the input signals are changed from “Full Black” to “Full White” (rising time, T_{rR}), and from “Full White” to “Full Black” (falling time, T_{rF}), respectively. The response time is interval between the 10% and 90% (1 frame at 60 Hz) of amplitudes.

$T_{rR} + T_{rF} = 5 \text{ msec (typ.)}$.

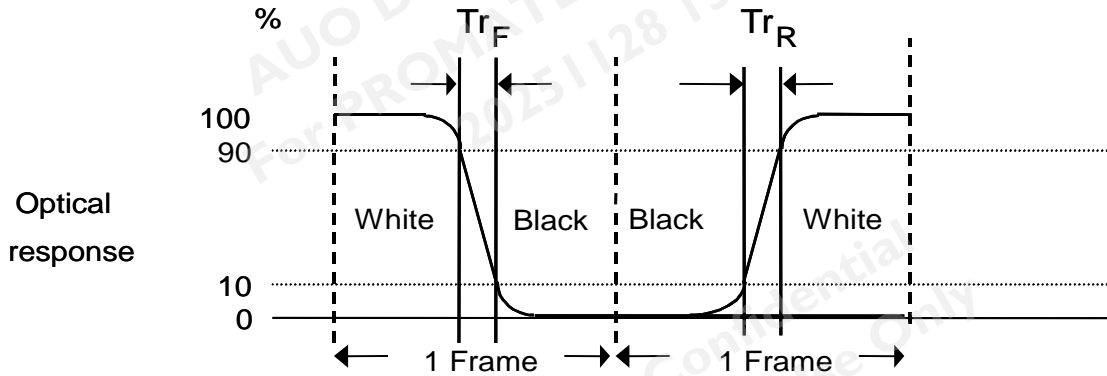

Note 5: Color chromaticity and coordinates (CIE) is measured by TOPCON SR-3

Note 6: Central luminance is measured by TOPCON SR-3

Note 7: Luminance uniformity of these 9 points is defined as below and measured by TOPCON SR-3

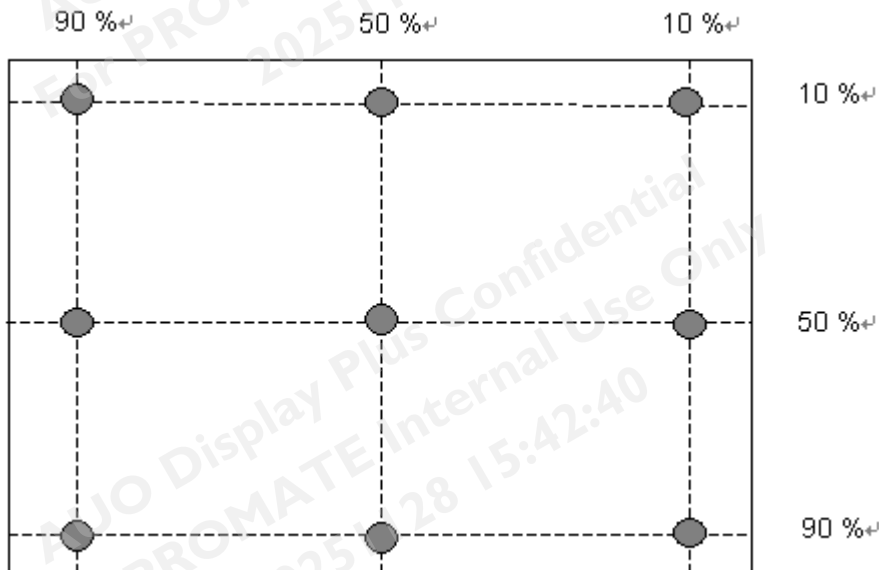

$$\text{Uniformity} = \frac{\text{Minimum Luminance in 9 points (1 - 9)}}{\text{Maximum Luminance in 9 Points (1 - 9)}}$$

AUO Display+

3.0 Functional Block Diagram

The following diagram shows the functional block of the 21.5 inch Color TFT-LCD Module:

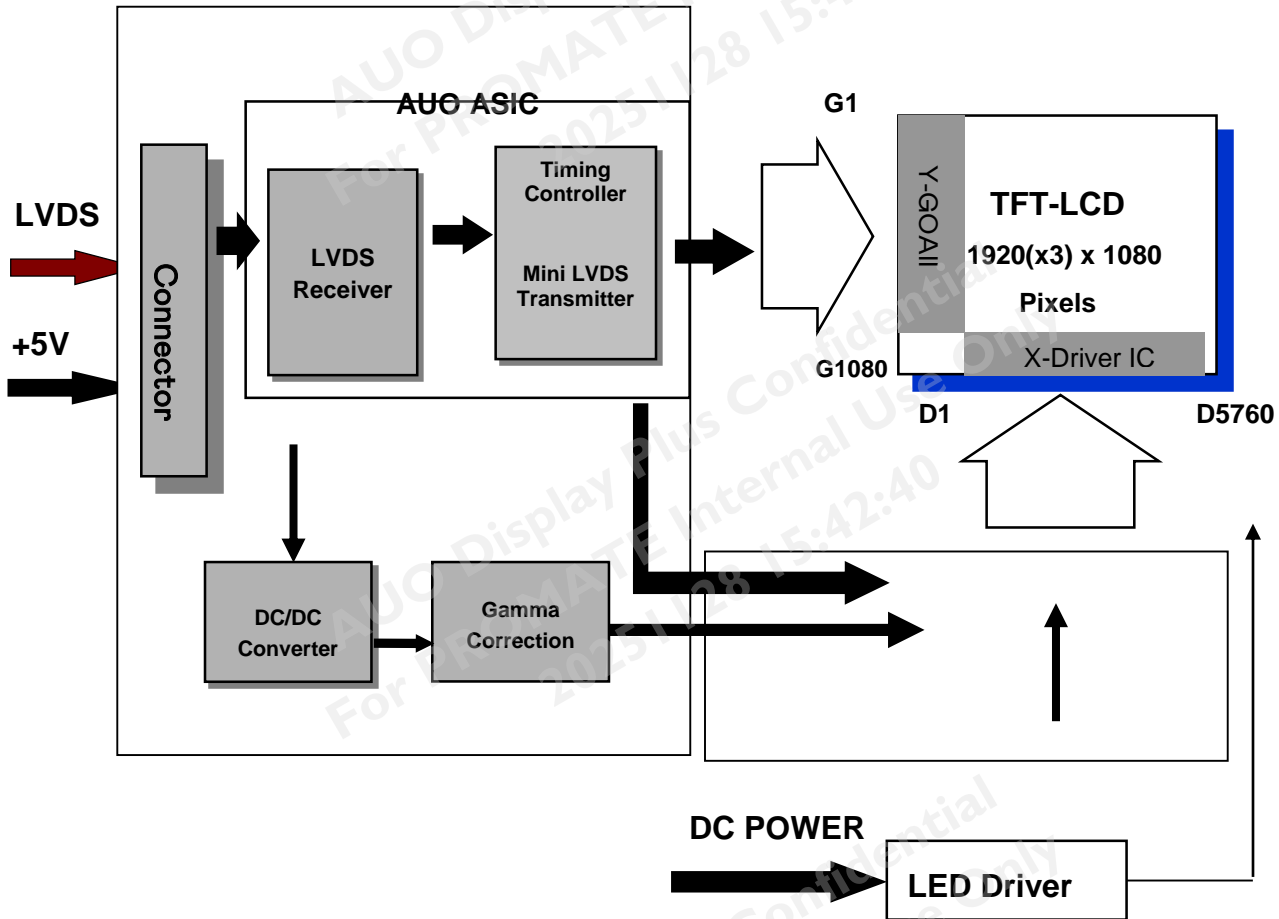

I/F PCB Interface:

Connector: FI-XB30SSRLA-HF16-R3500(JAE 30pin)

Mating Type:

FI-X30HL or FI-X30C2L-NPB

AUO Display+

4.0 Absolute Maximum Ratings

Absolute maximum ratings of the module are as following:

4.1 TFT LCD Module

Item	Symbol	Min	Max	Unit	Conditions
Logic/LCD Drive Voltage	VDD	-0.3	+5.5	[Volt]	Note 1,2

4.2 Absolute Ratings of Environment

Item	Symbol	Min.	Max.	Unit	Conditions
Operating Temperature	TOP	-20	70	[°C]	Note 3 & 4
Operation Humidity	HOP	5	90	[%RH]	
Storage Temperature	TST	-20	70	[°C]	
Storage Humidity	HST	5	90	[%RH]	

Note 1: With in Ta (25 °C)

Note 2: Permanent damage to the device may occur if exceeding maximum values

Note 3: For quality performance, please refer to AUO IIS(Incoming Inspection Standard).

Note 4: Operation Temperature +70°C is defined as panel surface temperature.

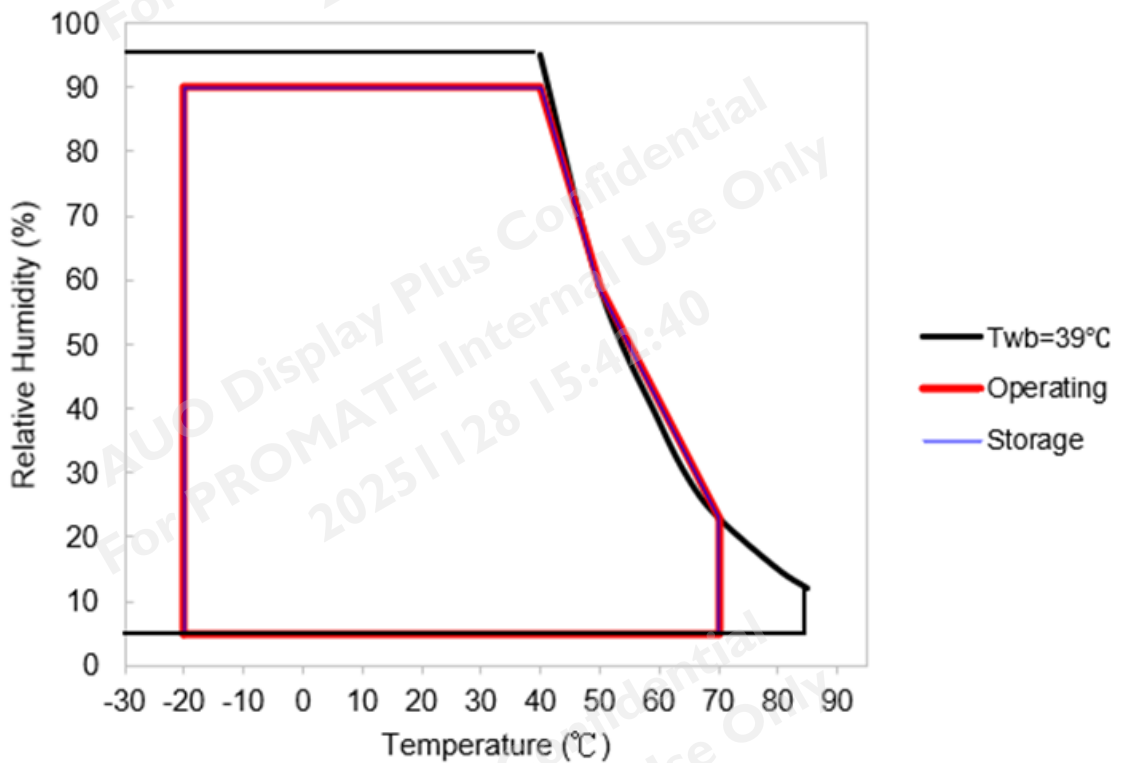

AUO Display+

5.0 Electrical characteristics

5.1 TFT LCD Module

5.1.1 Power Specification

Input power specifications are as follows:

Symbol	Parameter	Min	Typ	Max	Unit	Conditions
VDD	Logic/LCD Drive Voltage	4.5	5.0	5.5	[Volt]	+/-10%
IDD	Input Current	-	0.5	0.6	[A]	VDD= 5.0V, All White Pattern At 60Hz,
PDD	VDD Power	-	2.5	3	[Watt]	VDD= 5.0V, All White Pattern At 60Hz
IRush	Inrush Current	-	2.7	3.4	[A]	Note 1
VDDrp	Allowable Logic/LCD Drive Ripple Voltage	-	-	300	[mV] p-p	VDD= 5.0V, All White Pattern At 60Hz

Note 1: Measurement conditions:

The duration of rising time of power input is 470us.

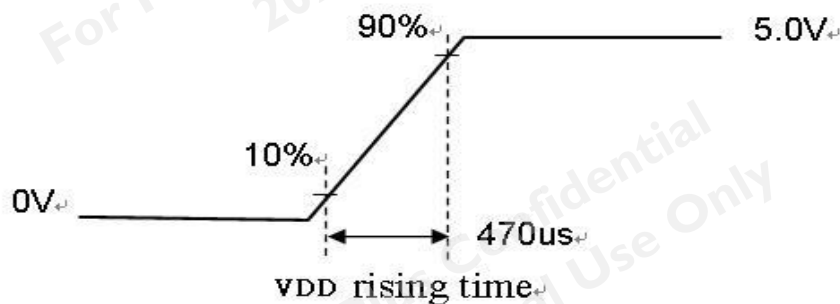
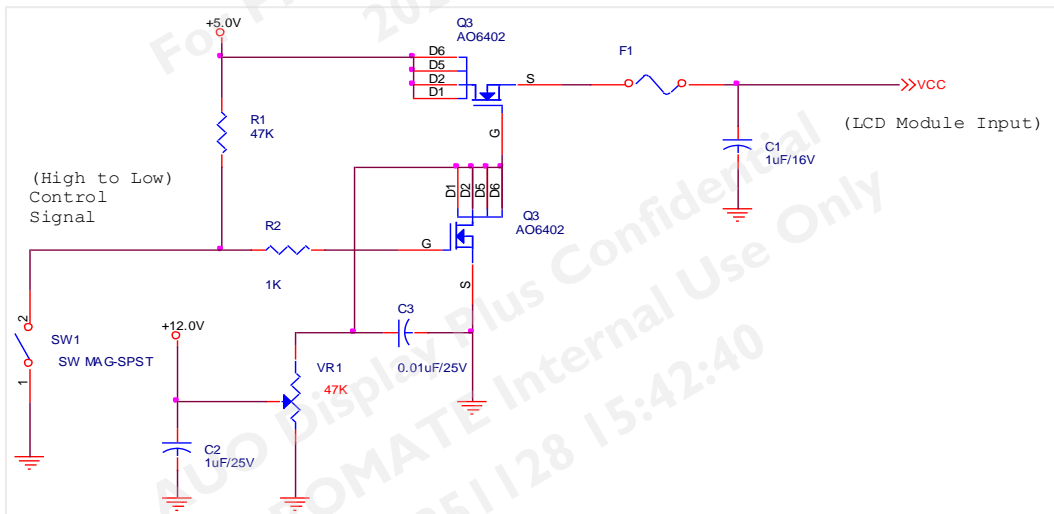

AUO Display+

5.1.2 Signal Electrical Characteristics

Input signals shall be low or Hi-Z state when VDD is off. Please refer to specifications of SN75LVDS82DGG (Texas Instruments) in detail.

Characteristics of each signal are as follows:

Symbol	Parameter	Min	Typ	Max	Units	Condition
V _{TH}	Differential Input High Threshold	-		100	[mV]	V _{ICM} = 1.2V Note 1
V _{TL}	Differential Input Low Threshold	-100		-	[mV]	V _{ICM} = 1.2V Note 1
V _{ID}	Input Differential Voltage	100	400	600	[mV]	Note 1
V _{ICM}	Differential Input Common Mode Voltage	1.125	-	1.375	[V]	V _{TH} -V _{TL} = 200mV (max) Note 1

Note 1: LVDS Signal Waveform

Single-End

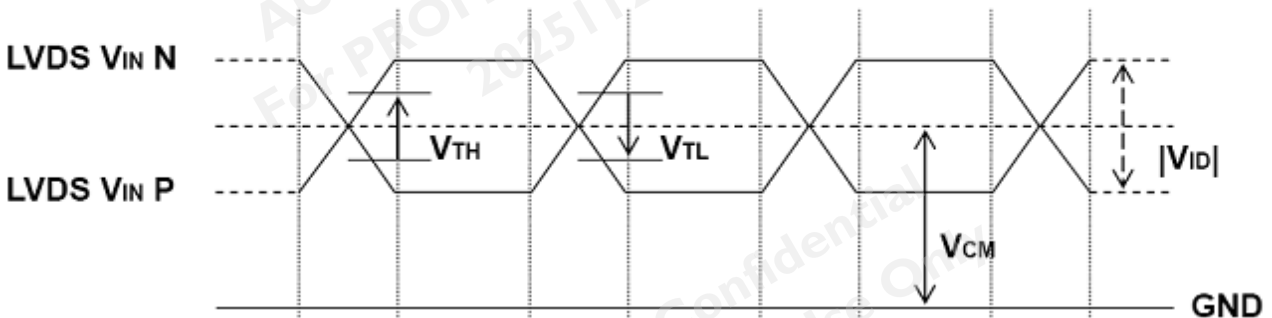

Differential Signal

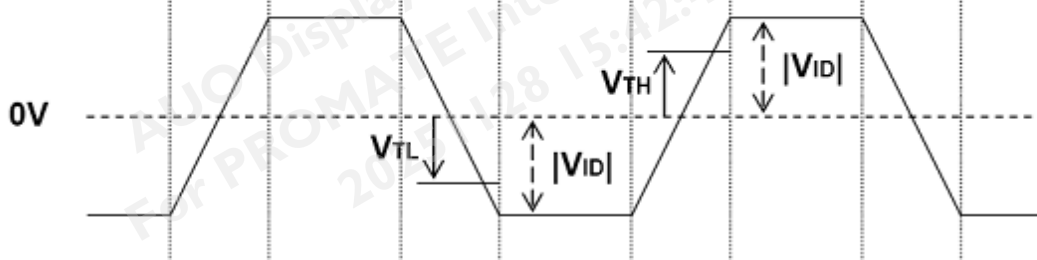

AUO Display+

5.2 Backlight Unit (OM)

Following characteristics are measured under a stable condition at 25 °C (Room Temperature):

Symbol	Parameter	Min.	Typ.	Max.	Unit	Remark
VCC	Input Voltage	10.8	12	13.2	[Volt]	
Ivcc	Input Current		1.44	1.73	[A]	100% PWM Duty
Pvcc	Power Consumption		17.28	20.76	[Watt]	100% PWM Duty
Irush LED	Inrush Current	-		3	[A]	at rising time=470us
VLED on/off	On Control Voltage	3	5	5.5	Volt	
	Off Control Voltage			0.8	Volt	
F _{PWM}	Dimming Frequency	200	-	20k	[Hz]	
	Swing Voltage	3	3.3	5	V	
	High Voltage	3	3.3	5	Volt	
	Low Voltage			0.8	Volt	
	Dimming Duty 200 Hz~5K Hz	5	-	100	%	
	Dimming Duty 5K Hz~20K Hz	15	-	100	%	
I _F	LED Forward Current		360		mA	Ta = 25 °C
V _F	LED Forward Voltage	43.2	46.4	49.6	Volt	I _F =90mA, Ta = 25°C
P _{LED}	LED Power Consumption	-	16.7	17.86	Watt	I _F =90mA, Ta = 25°C
Operation Lifetime		50,000			Hrs	I _F =90mA, Ta= 25°C

Note 1: Ta means ambient temperature of TFT-LCD module.

Note 2: VCC, Ivcc, Pvcc, Irush LED are defined for LED B/L.(100% duty of PWM dimming)

Note 3: I_F, V_F, P_{LED} are defined for single LED.

Note 4: If G215HAN02.0 module is driven by high current or at high ambient temperature & humidity condition. The operating life will be reduced.

Note 5: Operation life means brightness goes down to 50% initial brightness. Minimum operating life time is estimated data.

Note 6: Each LED light bar consists of 64 pcs LED package (16 strings x 4 pcs / string)

AUO Display+

6.2 The input data format

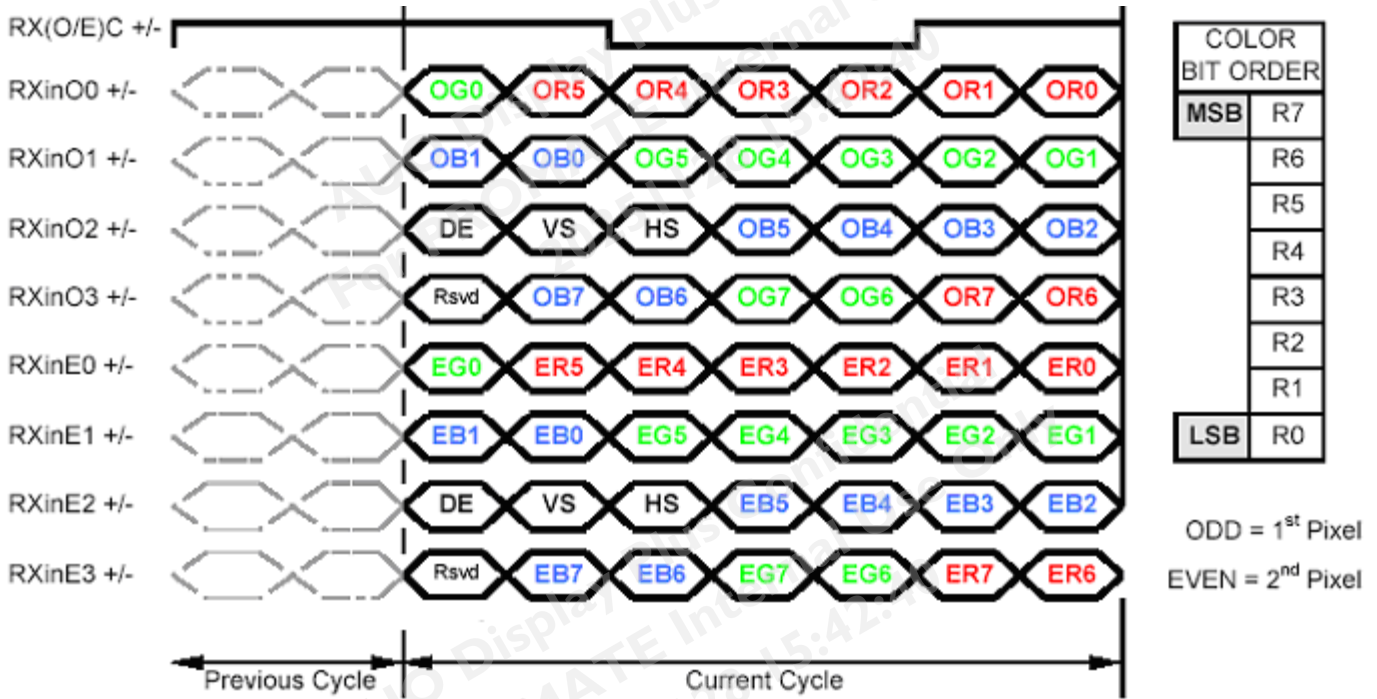

Note1: Normally DE mode only. VS and HS on EVEN channel are not used.

Note2: Please follow VESA.

Note3: 8-bits signal input.

AUO Display+

6.3 Signal Description

The module using a pair of LVDS receiver SN75LVDS82 / SN75LVDS83 (Texas Instruments) or compatible. LVDS is a differential signal technology for LCD interface and high speed data transfer device. Transmitter shall be SN75LVDS83(negative edge sampling) or compatible. The first LVDS port(RxOxxx) transmits odd pixels while the second LVDS port(RxExxx) transmits even pixels.

PIN #	SIGNAL NAME	DESCRIPTION
1	RXOIN0-	Negative LVDS differential data input (Odd data)
2	RXOIN0+	Positive LVDS differential data input (Odd data)
3	RXOIN1-	Negative LVDS differential data input (Odd data)
4	RXOIN1+	Positive LVDS differential data input (Odd data)
5	RXOIN2-	Negative LVDS differential data input (Odd data, H-Sync,V-Sync,DSPTMG)
6	RXOIN2+	Positive LVDS differential data input (Odd data, H-Sync,V-Sync,DSPTMG)
7	GND	Power Ground
8	RXOCLKIN-	Negative LVDS differential clock input (Odd clock)
9	RXOCLKIN+	Positive LVDS differential clock input (Odd clock)
10	RXOIN3-	Negative LVDS differential data input (Odd data)
11	RXOIN3+	Positive LVDS differential data input (Odd data)
12	RXEIN0-	Negative LVDS differential data input (Even data)
13	RXEIN0+	Positive LVDS differential data input (Even data)
14	GND	Power Ground
15	RXEIN1-	Negative LVDS differential data input (Even data)
16	RXEIN1+	Positive LVDS differential data input (Even data)
17	GND	Power Ground
18	RXEIN2-	Negative LVDS differential data input (Even data)
19	RXEIN2+	Positive LVDS differential data input (Even data)
20	RXECLKIN-	Negative LVDS differential clock input (Even clock)
21	RXECLKIN+	Positive LVDS differential clock input (Even clock)
22	RXEIN3-	Negative LVDS differential data input (Even data)
23	RXEIN3+	Positive LVDS differential data input (Even data)
24	GND	Power GND
25	Aging	NC (GND)
26	SCL for PVCOM	NC
27	SDA for PVCOM	NC
28	VDD	+5.0V Power Supply
29	VDD	+5.0V Power Supply
30	VDD	+5.0V Power Supply

Note1: Start from right side

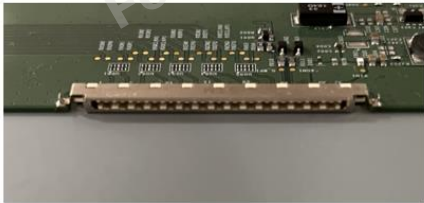

Note2: Input signals of clock shall be the same timing.

Note3: Please follow TV VESA Pin Assignment.

6.4 Timing Characteristics

Signal	Item	Symbol	Min	Typ	Max	Unit
V-section	Period	T_v	1094	1130	1836	Th
	Active	$T_{disp(v)}$	1080	1080	1080	Th
	Blanking	$T_{bp(v)}+T_{fp(v)}+PW_{vs}$	14	50	756	Th
H-section	Period	T_h	1000	1050	1678	Tclk
	Active	$T_{disp(h)}$	960	960	960	Tclk
	Blanking	$T_{bp(h)}+T_{fp(h)}+PW_{hs}$	40	90	718	Tclk
Clock	Period	Tclk	11.2	14	18.6	ns
	Frequency	Freq.	53.7	71.2	90	MHz
Frame Rate	Frame Rate	$1/T_v$	50	60	75	Hz

Note 1: Only DE mode operation.

The input of Hsync & Vsync signal does not have an effect upon the LCD normal operation.

Note 2: The performance of the electro-optical characteristics may be influenced by variance of the vertical refresh rates.

Note 3: Horizontal period should be even.

AUO Display+

6.5 Timing diagram

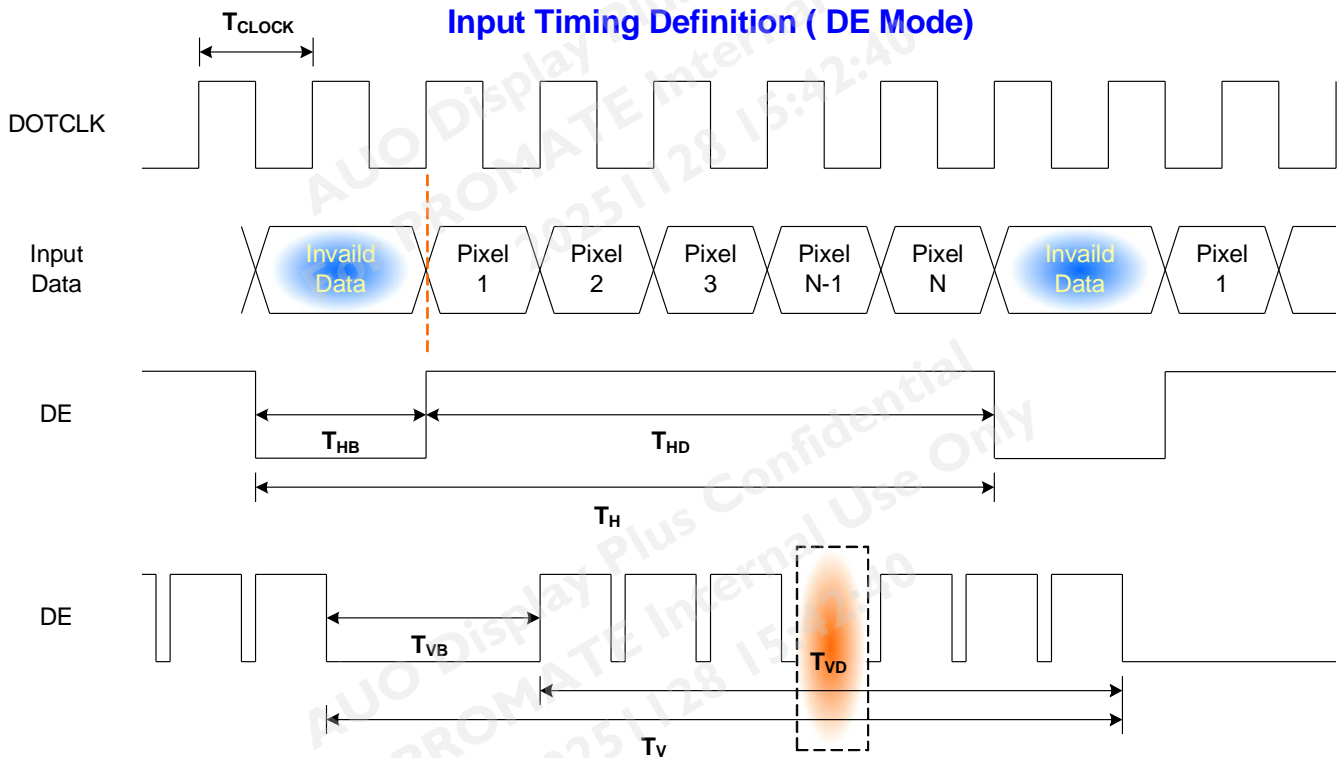

AUO Display+

6.6 Power ON/OFF Sequence

VDD power and LED on/off sequence are as follows. Interface signals are also shown in the chart. Signals from any system shall be Hi-Z state or low level when VDD is off.

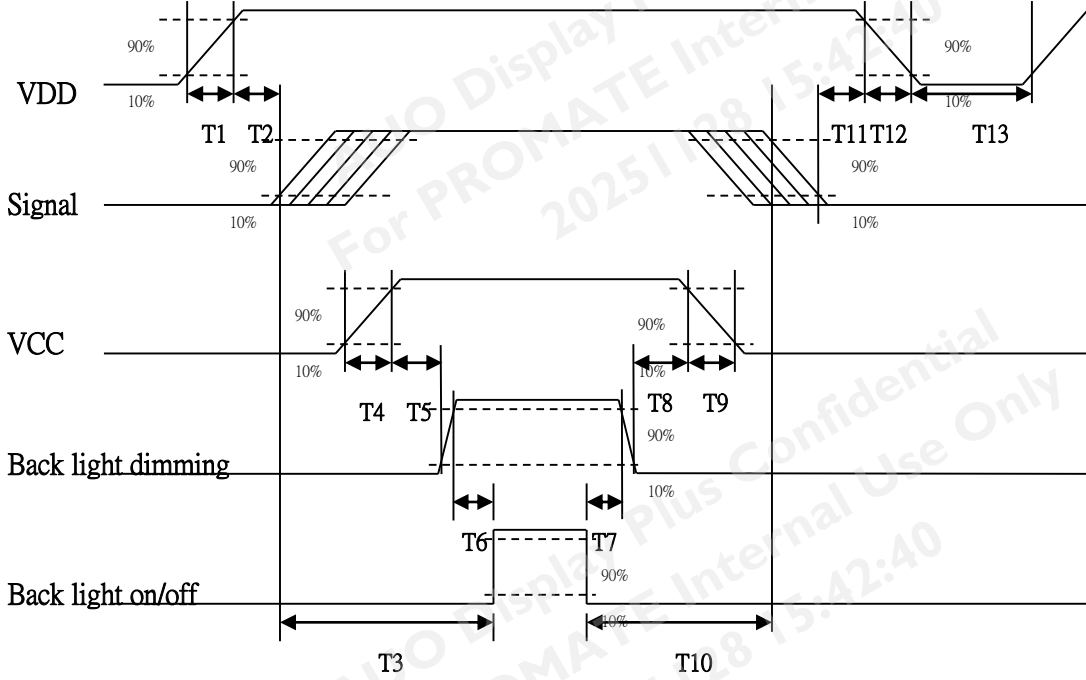

Power ON/OFF sequence timing

Parameter	Value			Units
	Min.	Typ.	Max.	
T1	0.5	-	10	[ms]
T2	0	40	50	[ms]
T3	200	-	-	[ms]
T4	0.5	-	10	[ms]
T5	10	-	-	[ms]
T6	10	-	-	[ms]
T7	0	-	-	[ms]
T8	10	-	-	[ms]
T9	-	-	10	[ms]
T10	110	-	-	[ms]
T11	0.5	16	50	[ms]
T12	-	-	100	[ms]
T13	1000	-	-	[ms]



AUO Display+

7.0 Connector & Pin Assignment

Physical interface is described as for the connector on module. These connectors are capable of accommodating the following signals and will be following components.

7.1 TFT LCD Module

Connector Name / Designation	Interface Connector / Interface card
Manufacturer	SIN SHENG TERMINAL & MACHINE INC(STM)
Type Part Number	MSBKT2407P30HB (STM 30pin)
Mating Housing Part Number	FI-X30HL or FI-X30C2L-NPB or Compatible

7.1.1 Pin Assignment

Pin#	Signal Name	Pin#	Signal Name
1	RxOIN0-	2	RxOIN0+
3	RxOIN1-	4	RxOIN1+
5	RxOIN2-	6	RxOIN2+
7	GND	8	RxOCLKIN-
9	RxOCLKIN+	10	RxOIN3-
11	RxOIN3+	12	RxEIN0-
13	RxEIN0+	14	GND
15	RxEIN1-	16	RxEIN1+
17	GND	18	RxEIN2-
19	RxEIN2+	20	RxECLKIN-
21	RxECLKIN+	22	RxEIN3-
23	RxEIN3+	24	GND
25	Aging	26	SCL For PVCOM
27	SDA For PVCOM	28	VDD
29	VDD	30	VDD

AUO Display+

7.2 LED Backlight Unit: LED Driver Connector

Connector Name / Designation	LED Connector
Manufacturer	SIN SHENG TERMINAL & MACHINE INC(STM)
Connector Model Number	MS24049HJ
Mating Connector Model Number	P24049 or Compatible

7.3 LED Driver Connector Pin Assignment

Pin#	Signal Name
1	12V
2	12V
3	12V
4	NC
5	ENABLE
6	PWM
7	GND
8	GND
9	GND





AUO Display+

Product Specification

G215HAN02.0

8.0 Reliability Test

Environment test conditions are listed as following table.

Items	Required Condition	Note
Temperature Humidity Bias (THB)	Ta= 50°C, 80%RH, 300hours	3 ,4
High Temperature Operation (HTO)	Ta= 70°C, 300hours	3 ,4
Low Temperature Operation (LTO)	Ta= -20°C, 300hours	3 ,4
High Temperature Storage (HTS)	Ta= 70°C, 300hours	3 ,4
Low Temperature Storage (LTS)	Ta= -20°C, 300hours	
Vibration Test (Non-operation)	Acceleration: 1.5 G Wave: Random Frequency: 10 - 200 Hz Sweep: 30 Minutes each Axis (X, Y, Z)	
Shock Test (Non-operation)	Acceleration: 50 G Wave: Half-sine Active Time: 20 ms Direction: ±X, ±Y, ±Z (one time for each Axis)	
Drop Test	Height: 61 cm, package test	
Thermal Shock Test (TST)	-20°C /30min, 50°C /30min, 100 cycles	1
On/Off Test	On/10sec, Off/10sec, 30,000 cycles	
ESD (Electro Static Discharge)	Contact Discharge: ± 8KV, 150pF(330Ω) 1sec, 8 points, 25 times/ point.	2
	Air Discharge: ± 15KV, 150pF(330Ω) 1sec 8 points, 25 times/ point.	
Altitude Test	Operation:10,000 ft Non-Operation:30,000 ft	

Note 1: The TFT-LCD module will not sustain damage after being subjected to 100 cycles of rapid temperature change. A cycle of rapid temperature change consists of varying the temperature from -20°C to 70°C, and back again. Power is not applied during the test. After temperature cycling, the unit is placed in normal room ambient for at least 4 hours before power on.

Note 2: According to EN61000-4-2 , ESD class B: Some performance degradation allowed. No data lost. Self-recoverable. No hardware failures.

Note 3: To inspect TFT-LCD module after reliability test, please store it at room temperature and room humidity for 24 hours at least in advance.

Note 4: The high temperature test item: THB & HTO & HTS & Thermal Shock, Mura shall be ignored.

G215HAN02.0. ver. 1.0

AUO Display+

9.0 Shipping Label & Packaging

9.1 Shipping Label

The label is on the panel as shown below:

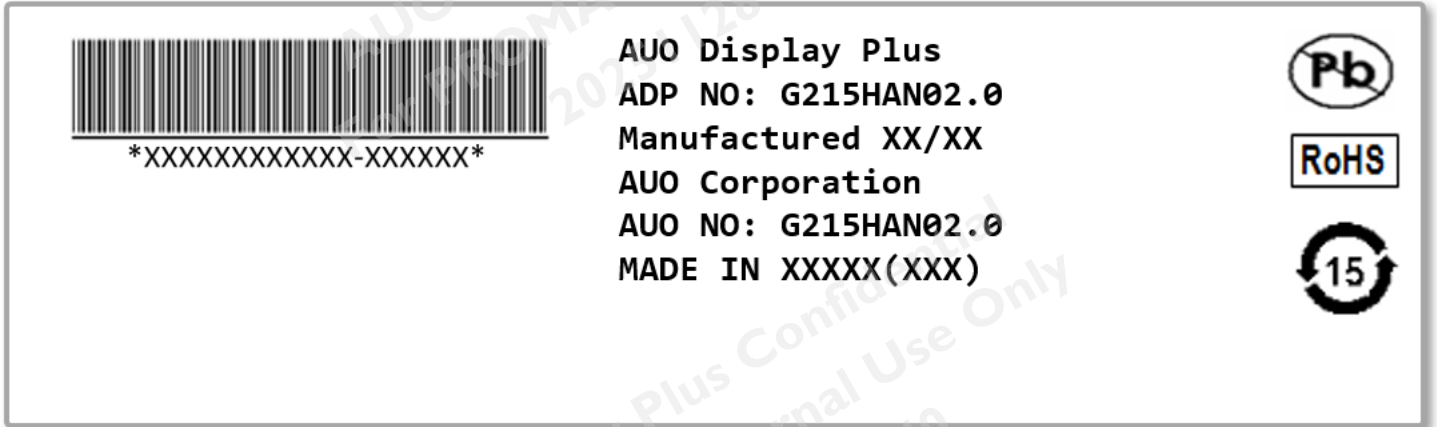

Note 1: For Pb Free products, AUO will add  for identification.

Note 2: For RoHS compatible products, AUO will add  for identification.

Note 3: For China RoHS compatible products, AUO will add  for identification.

Note 4: The Green Mark will be presented only when the green documents have been ready by AUO Internal Green Team.

AUO Display+

9.2 Packaging

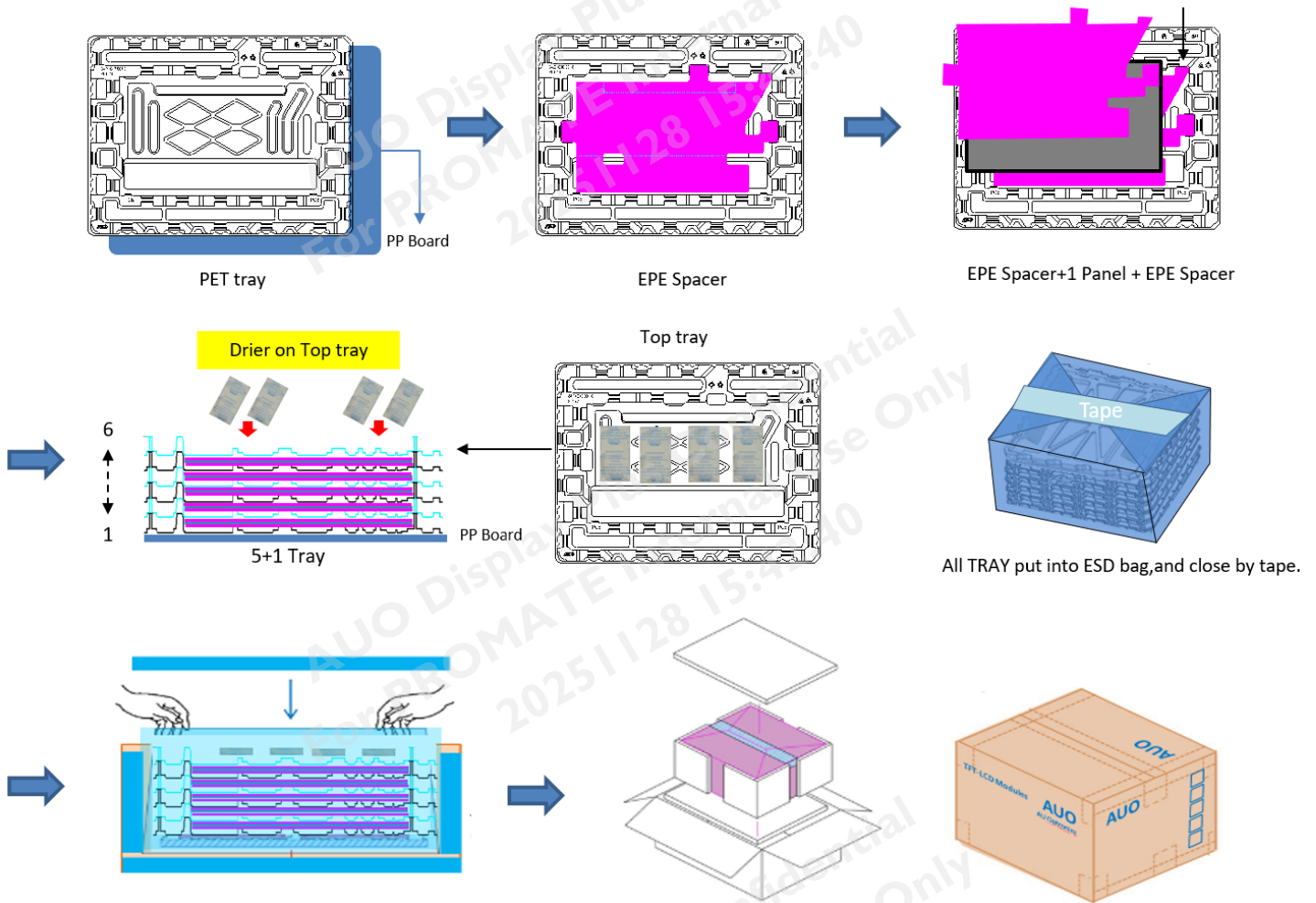

Max capacity : 5 TFT-LCD module per carton

Max weight: 14.5 kg per carton

Outside dimension of carton: 740mm*570mm*255mm

Pallet size : 1150mm*840mm*132mm

Box stacked:

By air_max : (2 *1) *5 layers , one pallet put 10 boxes , total 50 pcs module

By sea_max : (2 *1) *5 layers + (2 *1) *2 layers ,total 70 pcs module

By sea_HQ_max : (2 *1) *5 layers + (2 *1) *3 layers ,total 80 pcs modul



AUO Display+

Product Specification

G215HAN02.0

10.0 Mechanical Characteristics

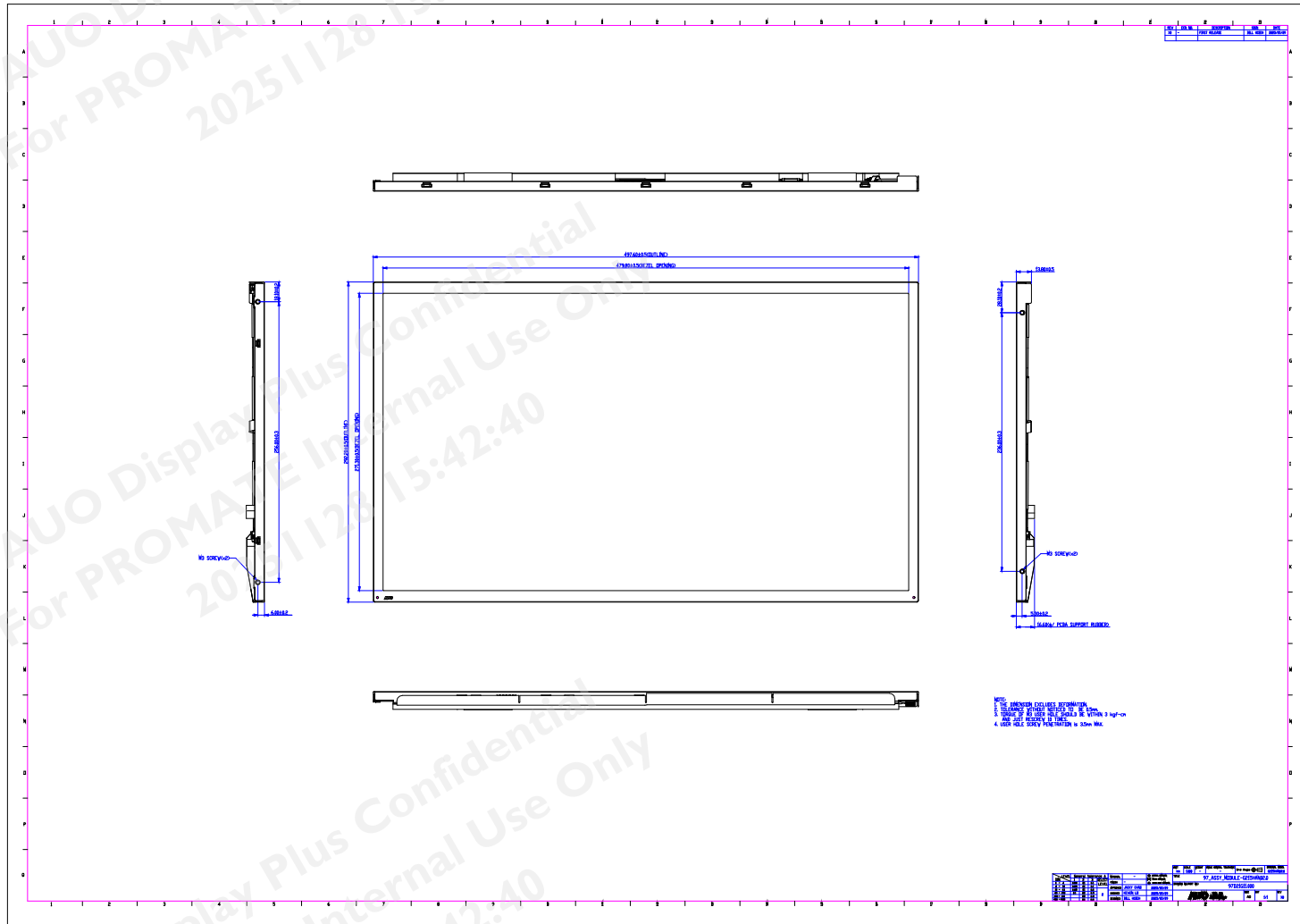

G215HAN02.0. ver. 1.0

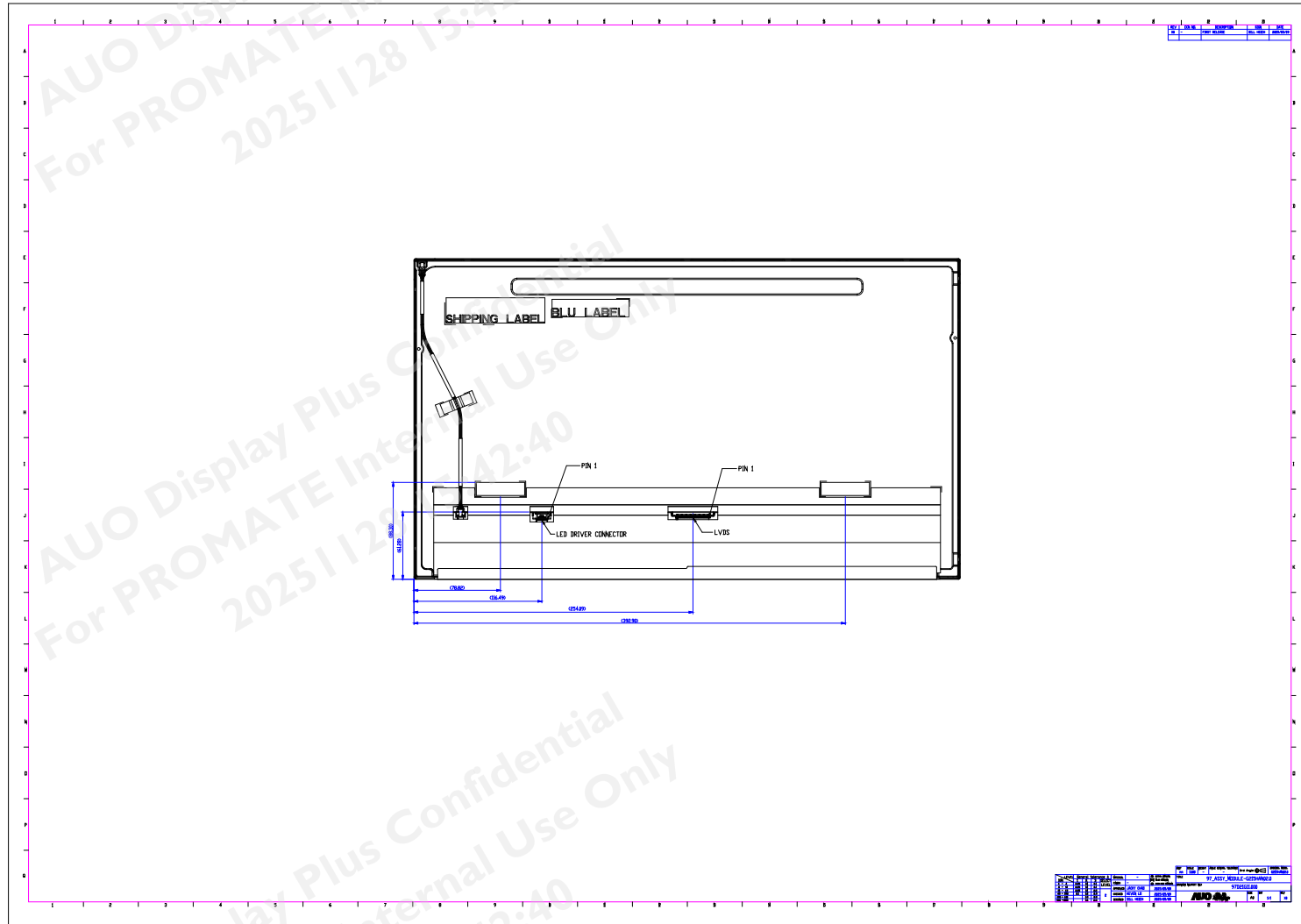

AUO Display+

11 Safety

11.1 Keen Edge Requirements

There will be no sharp edges or comers on the display assembly that could cause injury.

11.2 Materials

11.2.1 Toxicity

There will be no carcinogenic materials used anywhere in the display module. If toxic materials are used, they will be reviewed and approved by the responsible AUO toxicologist.

11.2.2 Flammability

The printed circuit board will be made from material rated 94-V1 or better. The actual UL flammability rating will be printed on the printed circuit board.

11.3 Capacitors

If any polarized capacitors are used in the display assembly, provisions will be made to keep them from being inserted backwards.

11.4 International Safety Standard Compliance

The TFT-LCD module will satisfy all requirements for compliance to:IEC/UL 62368-1