



PROPRIETARY NOTE

THIS SPECIFICATION IS THE PROPERTY OF BOE SDT AND SHALL NOT BE REPRODUCED OR COPIED WITHOUT THE WRITTEN PERMISSION OF BOE SDT AND MUST BE RETURNED TO BOE SDT UPON ITS REQUEST

SR100881001

Rev.0

2021.4.14

TITLE: TPA088-001V03 (AA)
Product Specification

| ITEM | SIGNATURE | ITEM | SIGNATURE | | |
|---------------|-------------------|-------------|------------------|-----|-----|
| Prepared | 陈小娇 张蒙蒙 张祥杰 | Checked | 谢晓波 | 李青永 | 湛志国 |
| Countersigned | 刘俊国 | | | | |

Beijing BOE Special Display Technology CO.,LTD

CONTENT LIST

| | |
|--|----|
| Cover | 1 |
| Content List | 2 |
| Records Of Revisions | 3 |
| 1. General Description | 4 |
| 2. Absolute Maximum Ratings | 6 |
| 3. Electrical Specification | 6 |
| 4. Optical Specifications | 7 |
| 5. Interface Connection | 10 |
| 6. Signal Timing Specification | 13 |
| 7. Input Signals Display Colors & Gray Scale of Colors | 15 |
| 8. Power Sequence | 16 |
| 9. Mechanical Characteristics | 17 |
| 10. Reliability Test | 19 |
| 11. Packing | 20 |
| 12. Handling & Cautions | 23 |

1.0 GENERAL DESCRIPTION

1.1 Introduction

8.8 768×768 is a color active matrix TFT-LCD model using amorphous silicon TFT's (Thin Film Transistors) as an active switching devices. This model is composed of a TFT-LCD Panel and a driving circuit. It is a transmissive type display operating in the normal black. This TFT-LCD has a 8.8 inch diagonally measured active area with 768×768 resolutions (768 horizontal by 768 vertical pixel array). Each pixel is divided into RED, GREEN, BLUE dots which are arranged in 2 domain stripe and this panel can display 16.7M colors.

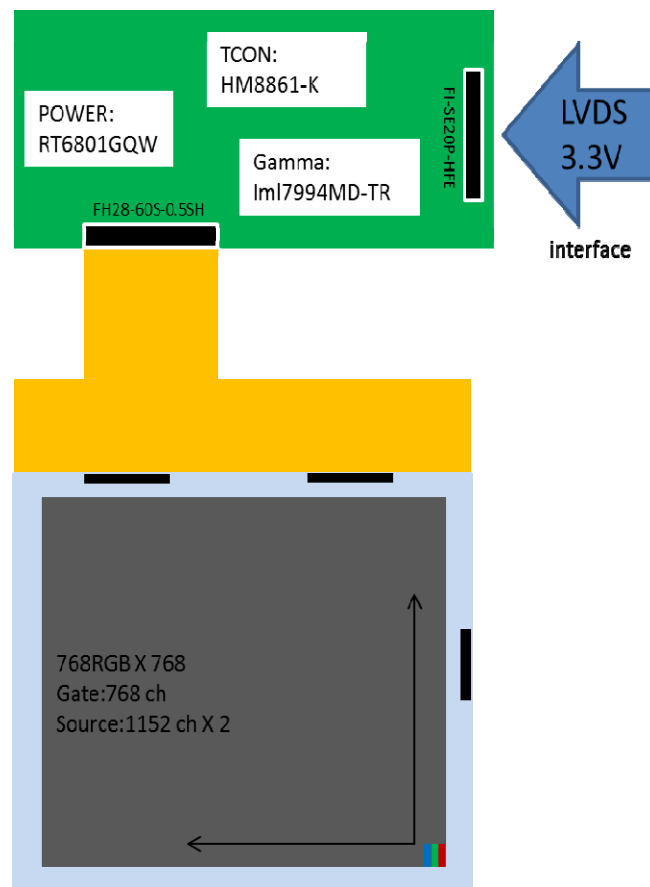

1.2 Features

- 0.5t Glass (Single)
- Wide operating temperature
- FOG Design
- Display 16.7M colors
- High contrast ratio, wide viewing angle

1.3 General Specifications (H: horizontal length, V: vertical length)

| Parameter | Specification | Unit | Remark |
|-----------------------------------|-----------------------------------|--------|----------|
| Active Area | 157.824(H) × 157.824(V) | mm | |
| Number of Pixels | 768(H)RGB × 768(V) | pixels | |
| Pixel Pitch | 205.5(H) × 205.5(V) | um | |
| Pixel Arrangement | RGB 2 domain stripe | | |
| Display Colors | 16.7M | colors | |
| Color Gamut | 68% | | Min |
| Display Mode | Normally black, Transmissive mode | | |
| Dimensional Outline | 169(H)×169(V)×1.287(D) | mm | w/o PCBA |
| Viewing Direction (Human Eye) | U/D/L/R free viewing direction | | Note1 |
| Weight | 95(max.) | g | |
| Surface Treatment | CF: AG25 TFT: AG25, 带补偿 | | |

Note:

1. At the U/D/L/R direction, the viewing angle is same.

2.0 Absolute Maximum Ratings

The followings are maximum values which, if exceed, may cause faulty operation or damage to the unit. Make sure all the design characteristics are adequate before the panel is initialed. All the measurements should be operated with driver IC and experimental FPC mounted.

[VSS = GND = 0V]

| Parameter | Symbol | Min | Max | Unit | Remark |
|----------------------------|-----------------|-----|-----|------|-----------|
| Operating Voltage | V _{op} | 3.0 | 3.6 | V | Ta = 25°C |
| Operating Temperature | T _{OP} | -40 | +85 | °C | |
| Storage Temperature | T _{ST} | -55 | +85 | °C | |
| Operating Ambient Humidity | H _{op} | 20 | 80 | %RH | *1) |
| Storage Humidity | H _{st} | 20 | 80 | %RH | *1) |

Note:

*1) Temp ≤ 40°C 90% RH MAX.

3.0 ELECTRICAL SPECIFICATION

| Parameter | Symbol | Value | | | Unit | Remark |
|---|-------------------|-------|-----|------|------|-----------|
| | | min | typ | max | | |
| Power Supply Voltage | V _{DD} | 3.0 | 3.3 | 3.6 | V | |
| Power Supply Current | I _{DD} | - | 0.5 | 0.7 | A | |
| Power Consumption | P _D | - | - | 0.6 | W | Only cell |
| In-Rush Current | I _{RUSH} | - | - | 1.1 | A | |
| Permissible Input Ripple Voltage | V _{RF} | - | - | 100 | mV | |
| High Level Differential Input Threshold Voltage | V _{IH} | - | - | +100 | mV | |
| Low Level Differential Input Threshold Voltage | V _{IL} | -100 | - | - | mV | |
| Differential input voltage | V _{ID} | 100 | - | 600 | mV | |
| Differential input common mode voltage | V _{cm} | 0.7 | 1.2 | 1.6 | V | |

4.0 OPTICAL SPECIFICATIONS

4.1 Overview

The test of Optical specifications shall be measured in a dark room (ambient luminance ≤ 1 lux and temperature = $25 \pm 2^\circ\text{C}$) with the equipment of Luminance meter system (Topcon SR-UL1R and Westar TRD-100A) and test unit shall be located at an approximate distance 50cm from the LCD surface at a viewing angle of θ and Φ equal to 0° . The center of the measuring spot on the Display surface shall stay fixed.

The backlight should be operating for 30 minutes prior to measurement.

4.2 Optical Specifications

| Parameter | | Symbol | Condition | Min. | Typ. | Max. | Unit | Remark |
|-----------------------|------------|--------------------|--------------------|--------|--------|--------|------|---|
| Viewing Angle | Horizontal | $\Theta 3$ | CR > 10 | 85 | - | - | ° | Note 1 |
| | | $\Theta 9$ | | 85 | - | - | ° | |
| | Vertical | $\Theta 12$ | | 85 | - | - | ° | |
| | | $\Theta 6$ | | 85 | - | - | ° | |
| Contrast Ratio | | CR | $\Theta = 0^\circ$ | 900 | 1100 | - | - | Note 2 |
| Transmittance | | T(%) | $\Theta = 0^\circ$ | 4.3 | 4.7 | - | - | Note 3 |
| NSTC (CIE1976) | | % | $\Theta = 0^\circ$ | 68 | - | - | - | |
| Reproduction Of color | Red | Ru' | $\Theta = 0^\circ$ | 0.4366 | 0.4516 | 0.4666 | | Note 4 Color filter Glass with OC (By Backlight of BOE) |
| | | Rv' | | 0.5066 | 0.5216 | 0.5366 | | |
| | Green | Gu' | | 0.0995 | 0.1145 | 0.1295 | | |
| | | Gv' | | 0.544 | 0.559 | 0.574 | | |
| | Blue | Bu' | | 0.1433 | 0.1583 | 0.1733 | | |
| | | Bv' | | 0.181 | 0.196 | 0.211 | | |
| White | Wu' | $\Theta = 0^\circ$ | 0.1658 | 0.1808 | 0.197 | | | |
| | Wv' | | 0.4351 | 0.4501 | 0.467 | | | |
| Response Time | | Tr+Tf | $\Theta = 0^\circ$ | - | - | 30 | ms | Note 5 |
| Cross talk | | - | - | - | - | 2% | | Fig.3 |

Note:

1. Viewing angle is the angle at which the contrast ratio is greater than 10. The viewing are determined for the horizontal or 3, 9 o'clock direction and the vertical or 6, 12 o'clock direction with respect to the optical axis which is normal to the LCD surface (see FIG.1). Viewing angle measuring is based on WV Pol attached.

2. Contrast measurements shall be made at viewing angle of $\Theta = 0^\circ$ and at the center of the LCD surface.

Luminance shall be measured with all pixels in the view field set first to white, then to the dark (black) state. (See FIG.1) Luminance Contrast Ratio (CR) is defined mathematically.

$$CR = \frac{\text{Luminance when displaying a white raster}}{\text{Luminance when displaying a black raster}}$$

3. Transmittance is the value with Polarizer.

4. The color chromaticity coordinates specified in Table1 shall be calculated from The spectral data measured with all pixels first in red, green, blue and white.

Measurements shall be made at the center of the C/F.

Measurement condition is C - light source & Halogen Lamp

5. The electro-optical response time measurements shall be made as FIG.2 by switching the "data" input signal ON and OFF.

The times needed for the luminance to change from 10% to 90% is T_f , and 90% to 10% is T_r .

Figure 1. Measurement Set Up

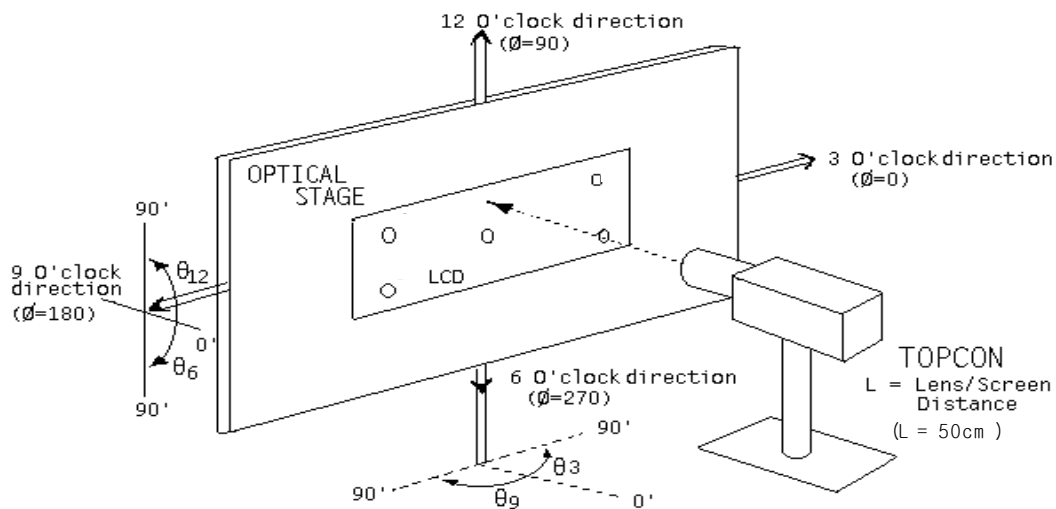

Figure 2. Response Time Testing

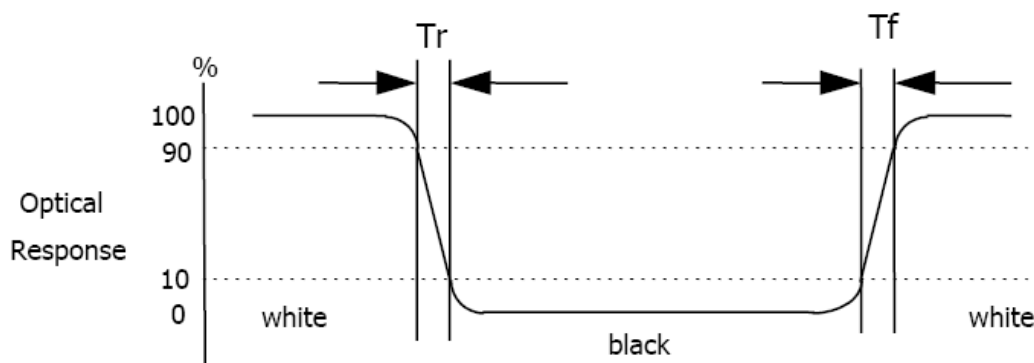
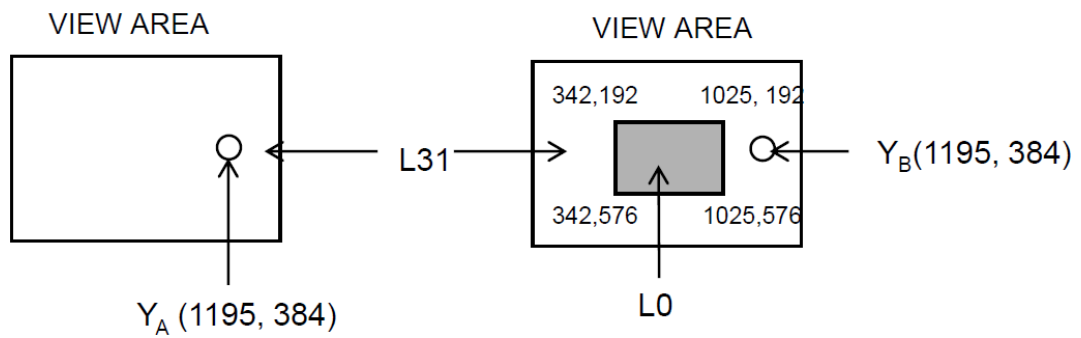

Figure 3. Cross Modulation Test Description



$$\text{Cross-Talk (\%)} = \left| \frac{Y_B - Y_A}{Y_A} \right| \times 100$$

Where:

Y_A = Initial luminance of measured area (cd/m²)

Y_B = Subsequent luminance of measured area (cd/m²)

The location measured will be exactly the same in both patterns

5.0 INTERFACE CONNECTION

5.1 Electrical Interface Connection

The FPC electronics interface connector is FH28-60S-0.5SH or Compatible and LVDS electronics interface connector is JAE FI-SE20P-HFE or Compatible.

The connector interface pin assignments are listed as follow.

Figure 4. LVDS Interface (unit: mm if unspecified)

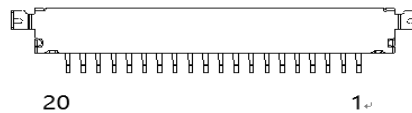

| No. | Symbol | Functions |
|-----|--------|-------------------------|
| 20 | VCC | Power supply 3.3V |
| 19 | VCC | Power supply 3.3V |
| 18 | GND | Ground |
| 17 | GND | Ground |
| 16 | D0- | Transmission Data of 0- |
| 15 | D0+ | Transmission Data of 0+ |
| 14 | GND | Ground |
| 13 | D1- | Transmission Data of 1- |
| 12 | D1+ | Transmission Data of 1+ |
| 11 | GND | Ground |
| 10 | D2- | Transmission Data of 2- |
| 9 | D2+ | Transmission Data of 2+ |
| 8 | GND | Ground |
| 7 | CLK- | Transmission Clock- |
| 6 | CLK+ | Transmission Clock+ |
| 5 | GND | Ground |
| 4 | D3- | Transmission Data of 3- |
| 3 | D3+ | Transmission Data of 3+ |
| 2 | GND | Ground |
| 1 | DPS | NC |

Figure 5. FPC Interface

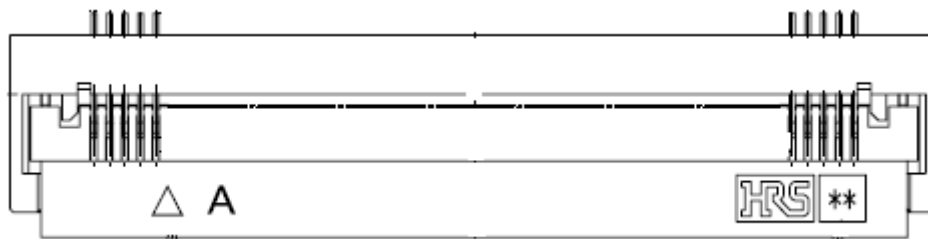

| Pin | Symbol | I/O | Description |
|-----|--------|-----|----------------------------|
| 1 | VCOM | I | common voltage |
| 2 | VCOM | I | common voltage |
| 3 | VCOM | I | common voltage |
| 4 | AVDD | P | voltage for analog circuit |
| 5 | AVDD | P | voltage for analog circuit |
| 6 | AVDD | P | voltage for analog circuit |
| 7 | AVSS | P | ground |
| 8 | AVSS | P | ground |
| 9 | AVSS | P | ground |
| 10 | V1 | I | gamma voltage 1 |
| 11 | V2 | I | gamma voltage 2 |
| 12 | V3 | I | gamma voltage 3 |
| 13 | V4 | I | gamma voltage 4 |
| 14 | V5 | I | gamma voltage 5 |
| 15 | V6 | I | gamma voltage 6 |
| 16 | V7 | I | gamma voltage 7 |
| 17 | V8 | I | gamma voltage 8 |
| 18 | GND | P | ground |
| 19 | V9 | I | gamma voltage 9 |
| 20 | V10 | I | gamma voltage 10 |
| 21 | V11 | I | gamma voltage 11 |
| 22 | V12 | I | gamma voltage 12 |
| 23 | V13 | P | gamma voltage 13 |
| 24 | V14 | I | gamma voltage 14 |
| 25 | V15 | I | gamma voltage 15 |
| 26 | V16 | I | gamma voltage 16 |
| 27 | GND | P | ground |
| 28 | MLV0P | I | mini-LVDS output pair 0 |
| 29 | MLV0N | I | mini-LVDS output pair 0 |
| 30 | GND | P | ground |
| 31 | MLV1P | I | mini-LVDS output pair 1 |
| 32 | MLV1N | I | mini-LVDS output pair 1 |
| 33 | GND | P | ground |

| | | | |
|----|----------|-----|-------------------------------|
| 34 | MLV2P | I | mini-LVDS output pair 2 |
| 35 | MLV2N | I | mini-LVDS output pair 2 |
| 36 | GND | P | ground |
| 37 | MLVCLK0P | I | mini-LVDS output clock pair |
| 38 | MLVCLK0N | I | mini-LVDS output clock pair |
| 39 | GND | P | ground |
| 40 | DIO1 | I/O | horizontal start pulse signal |
| 41 | /XAO | I | Output all on control |
| 42 | LD | I | load output signal |
| 43 | R/L | I | right/left scan selection |
| 44 | REV | I | data invert control |
| 45 | POL | I | polarity selection |
| 46 | DIO2 | I/O | horizontal start pulse signal |
| 47 | GND | P | ground |
| 48 | VCC | P | Voltage for digital circuit |
| 49 | VCC | P | Voltage for digital circuit |
| 50 | VCC | P | Voltage for digital circuit I |
| 51 | OEV | I | Gate driver output enable |
| 52 | U/D | I | up/down scan selection |
| 53 | CPV | I | vertical shift clock |
| 54 | STVU | I/O | vertical shift pulse signal |
| 55 | STVD | I/O | vertical shift pulse signal |
| 56 | VEE | P | gate off voltage |
| 57 | VEE | P | gate off voltage |
| 58 | GND | P | ground |
| 59 | VGG | P | gate on voltage |
| 60 | VGG | P | gate on voltage |

5.2 LVDS Input signal mapping

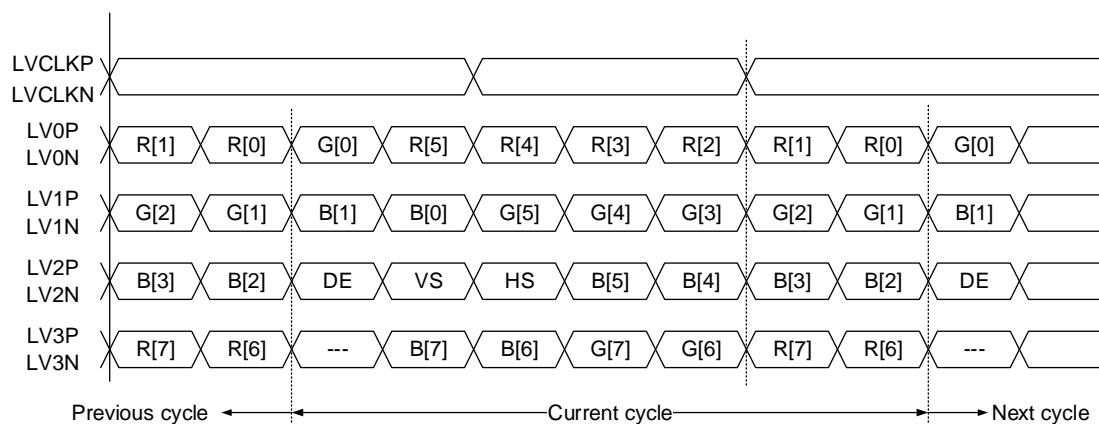

8 bit VESA mode

5.3 LVDS Input signal

| | | | |
|------------------------|-----|-----|-------|
| Vertical front porch | VFP | 3 | Lines |
| Vertical active timing | VVD | 768 | Lines |

6.2 Timing diagrams of interface signal

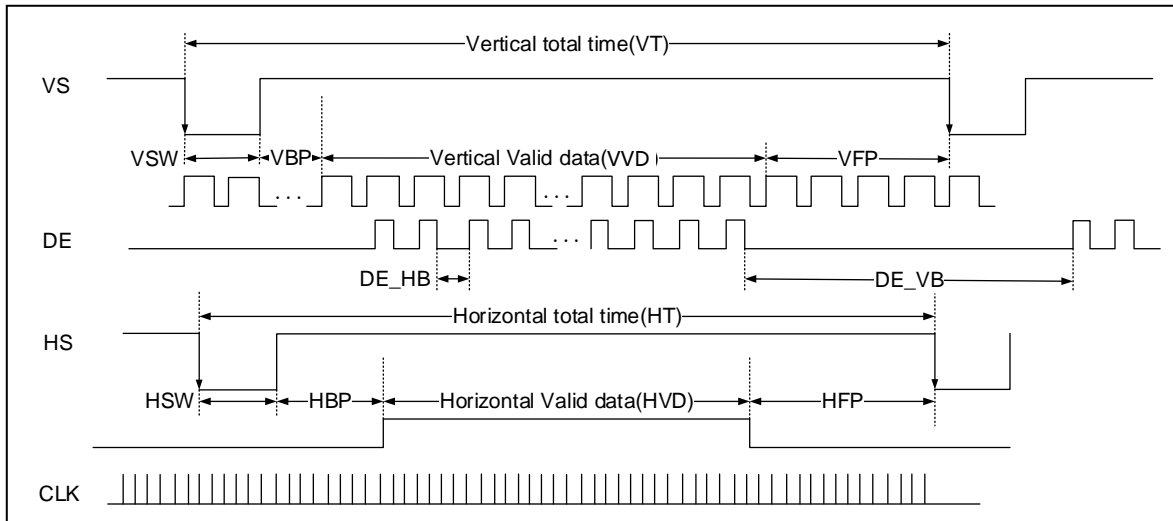

7.0 Input Signals Display Colors & Gray Scale of Colors

| Color & Gray Scale | | Input Data Signal | | | | | | | | | | | | | | | | | | | | | | | |
|---------------------|----------|-------------------|----|----|----|----|----|----|----|------------|----|----|----|----|----|----|----|-----------|----|----|----|----|----|----|----|
| | | Red Data | | | | | | | | Green Data | | | | | | | | Blue Data | | | | | | | |
| | | R7 | R6 | R5 | R4 | R3 | R2 | R1 | R0 | G7 | G6 | G5 | G4 | G3 | G2 | G1 | G0 | B7 | B6 | B5 | B4 | B3 | B2 | B1 | B0 |
| Basic Colors | Black | 0 | 0 | 0 | 0 | 0 | 0 | 0 | 0 | 0 | 0 | 0 | 0 | 0 | 0 | 0 | 0 | 0 | 0 | 0 | 0 | 0 | 0 | 0 | 0 |
| | Blue | 0 | 0 | 0 | 0 | 0 | 0 | 0 | 0 | 0 | 0 | 0 | 0 | 0 | 0 | 0 | 0 | 1 | 1 | 1 | 1 | 1 | 1 | 1 | 1 |
| | Green | 0 | 0 | 0 | 0 | 0 | 0 | 0 | 1 | 1 | 1 | 1 | 1 | 1 | 1 | 1 | 0 | 0 | 0 | 0 | 0 | 0 | 0 | 0 | |
| | Cyan | 0 | 0 | 0 | 0 | 0 | 0 | 0 | 1 | 1 | 1 | 1 | 1 | 1 | 1 | 1 | 1 | 1 | 1 | 1 | 1 | 1 | 1 | 1 | |
| | Red | 1 | 1 | 1 | 1 | 1 | 1 | 1 | 0 | 0 | 0 | 0 | 0 | 0 | 0 | 0 | 0 | 0 | 0 | 0 | 0 | 0 | 0 | 0 | |
| | Magenta | 1 | 1 | 1 | 1 | 1 | 1 | 1 | 0 | 0 | 0 | 0 | 0 | 0 | 0 | 0 | 0 | 1 | 1 | 1 | 1 | 1 | 1 | 1 | |
| | Yellow | 1 | 1 | 1 | 1 | 1 | 1 | 1 | 1 | 1 | 1 | 1 | 1 | 1 | 1 | 1 | 0 | 0 | 0 | 0 | 0 | 0 | 0 | 0 | |
| | White | 1 | 1 | 1 | 1 | 1 | 1 | 1 | 1 | 1 | 1 | 1 | 1 | 1 | 1 | 1 | 1 | 1 | 1 | 1 | 1 | 1 | 1 | 1 | |
| Gray Scale of Red | Black | 0 | 0 | 0 | 0 | 0 | 0 | 0 | 0 | 0 | 0 | 0 | 0 | 0 | 0 | 0 | 0 | 0 | 0 | 0 | 0 | 0 | 0 | 0 | |
| | △ | 0 | 0 | 0 | 0 | 0 | 0 | 1 | 0 | 0 | 0 | 0 | 0 | 0 | 0 | 0 | 0 | 0 | 0 | 0 | 0 | 0 | 0 | 0 | |
| | Darker | 0 | 0 | 0 | 0 | 0 | 0 | 1 | 0 | 0 | 0 | 0 | 0 | 0 | 0 | 0 | 0 | 0 | 0 | 0 | 0 | 0 | 0 | 0 | |
| | △ | ↑ | | | | | | | | ↑ | | | | | | | | ↑ | | | | | | | |
| | ▽ | ↓ | | | | | | | | ↓ | | | | | | | | ↓ | | | | | | | |
| | Brighter | 1 | 1 | 1 | 1 | 1 | 1 | 0 | 1 | 0 | 0 | 0 | 0 | 0 | 0 | 0 | 0 | 0 | 0 | 0 | 0 | 0 | 0 | 0 | |
| | ▽ | 1 | 1 | 1 | 1 | 1 | 1 | 0 | 0 | 0 | 0 | 0 | 0 | 0 | 0 | 0 | 0 | 0 | 0 | 0 | 0 | 0 | 0 | 0 | |
| | Red | 1 | 1 | 1 | 1 | 1 | 1 | 1 | 0 | 0 | 0 | 0 | 0 | 0 | 0 | 0 | 0 | 0 | 0 | 0 | 0 | 0 | 0 | 0 | |
| Gray Scale of Green | Black | 0 | 0 | 0 | 0 | 0 | 0 | 0 | 0 | 0 | 0 | 0 | 0 | 0 | 0 | 0 | 0 | 0 | 0 | 0 | 0 | 0 | 0 | 0 | |
| | △ | 0 | 0 | 0 | 0 | 0 | 0 | 0 | 0 | 0 | 0 | 0 | 0 | 0 | 0 | 1 | 0 | 0 | 0 | 0 | 0 | 0 | 0 | 0 | |
| | Darker | 0 | 0 | 0 | 0 | 0 | 0 | 0 | 0 | 0 | 0 | 0 | 0 | 0 | 0 | 1 | 0 | 0 | 0 | 0 | 0 | 0 | 0 | 0 | |
| | △ | ↑ | | | | | | | | ↑ | | | | | | | | ↑ | | | | | | | |
| | ▽ | ↓ | | | | | | | | ↓ | | | | | | | | ↓ | | | | | | | |
| | Brighter | 0 | 0 | 0 | 0 | 0 | 0 | 0 | 1 | 1 | 1 | 1 | 1 | 1 | 1 | 0 | 1 | 0 | 0 | 0 | 0 | 0 | 0 | 0 | |
| | ▽ | 0 | 0 | 0 | 0 | 0 | 0 | 0 | 1 | 1 | 1 | 1 | 1 | 1 | 1 | 0 | 0 | 0 | 0 | 0 | 0 | 0 | 0 | 0 | |
| | Green | 0 | 0 | 0 | 0 | 0 | 0 | 0 | 1 | 1 | 1 | 1 | 1 | 1 | 1 | 1 | 0 | 0 | 0 | 0 | 0 | 0 | 0 | 0 | |
| Gray Scale of Blue | Black | 0 | 0 | 0 | 0 | 0 | 0 | 0 | 0 | 0 | 0 | 0 | 0 | 0 | 0 | 0 | 0 | 0 | 0 | 0 | 0 | 0 | 0 | 0 | |
| | △ | 0 | 0 | 0 | 0 | 0 | 0 | 0 | 0 | 0 | 0 | 0 | 0 | 0 | 0 | 0 | 0 | 0 | 0 | 0 | 0 | 0 | 0 | 1 | |
| | Darker | 0 | 0 | 0 | 0 | 0 | 0 | 0 | 0 | 0 | 0 | 0 | 0 | 0 | 0 | 0 | 0 | 0 | 0 | 0 | 0 | 0 | 0 | 1 | |
| | △ | ↑ | | | | | | | | ↑ | | | | | | | | ↑ | | | | | | | |
| | ▽ | ↓ | | | | | | | | ↓ | | | | | | | | ↓ | | | | | | | |
| | Brighter | 0 | 0 | 0 | 0 | 0 | 0 | 0 | 0 | 0 | 0 | 0 | 0 | 0 | 0 | 0 | 1 | 1 | 1 | 1 | 1 | 1 | 0 | 1 | |
| | ▽ | 0 | 0 | 0 | 0 | 0 | 0 | 0 | 0 | 0 | 0 | 0 | 0 | 0 | 0 | 0 | 1 | 1 | 1 | 1 | 1 | 1 | 1 | 0 | |
| | Blue | 0 | 0 | 0 | 0 | 0 | 0 | 0 | 0 | 0 | 0 | 0 | 0 | 0 | 0 | 0 | 1 | 1 | 1 | 1 | 1 | 1 | 1 | 1 | |
| Gray Scale of White | Black | 0 | 0 | 0 | 0 | 0 | 0 | 0 | 0 | 0 | 0 | 0 | 0 | 0 | 0 | 0 | 0 | 0 | 0 | 0 | 0 | 0 | 0 | 0 | |
| | △ | 0 | 0 | 0 | 0 | 0 | 0 | 1 | 0 | 0 | 0 | 0 | 0 | 0 | 0 | 1 | 0 | 0 | 0 | 0 | 0 | 0 | 0 | 1 | |
| | Darker | 0 | 0 | 0 | 0 | 0 | 0 | 1 | 0 | 0 | 0 | 0 | 0 | 0 | 1 | 0 | 0 | 0 | 0 | 0 | 0 | 0 | 1 | 0 | |
| | △ | ↑ | | | | | | | | ↑ | | | | | | | | ↑ | | | | | | | |
| | ▽ | ↓ | | | | | | | | ↓ | | | | | | | | ↓ | | | | | | | |
| | Brighter | 1 | 1 | 1 | 1 | 1 | 1 | 0 | 1 | 1 | 1 | 1 | 1 | 1 | 1 | 0 | 1 | 1 | 1 | 1 | 1 | 1 | 0 | 1 | |
| | ▽ | 1 | 1 | 1 | 1 | 1 | 1 | 0 | 1 | 1 | 1 | 1 | 1 | 1 | 1 | 0 | 1 | 1 | 1 | 1 | 1 | 1 | 1 | 0 | |
| | White | 1 | 1 | 1 | 1 | 1 | 1 | 1 | 1 | 1 | 1 | 1 | 1 | 1 | 1 | 1 | 1 | 1 | 1 | 1 | 1 | 1 | 1 | 1 | |

Note: 0:Low Level Voltage, 1:High Level Voltage

8.0 Power Sequence

To prevent a latch-up or DC operation of the Open Cell, the power on/off sequence shall be as shown in below.

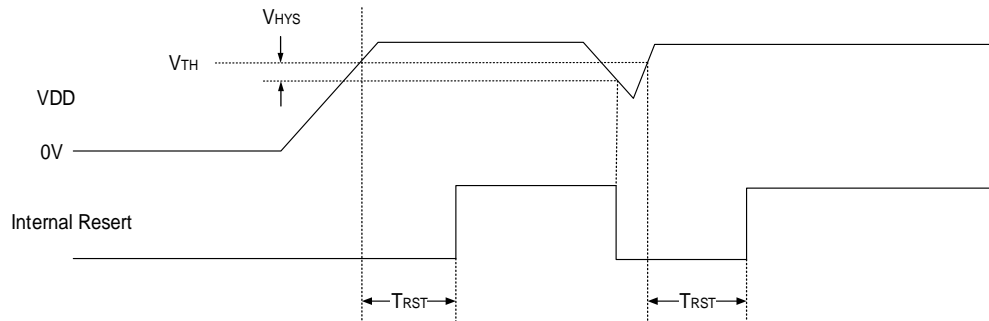

| Symbol | Parameter | Condition | Spec | | | Unit |
|-----------|-------------------------|-----------|------|-------|-----|------|
| | | | Min | Typ | Max | |
| V_{TH} | Reset threshold voltage | - | 1.7 | 1.9 | 2.1 | V |
| V_{HYS} | Hysteresis voltage | - | 200 | - | - | mV |
| T_{RST} | Time constant of RC | - | - | 0.8RC | - | s |

9.0 Mechanical Characteristics

9.1 Dimensional Requirements

| Parameter | Specification | Unit | Remark |
|---------------------|----------------------------|--------|--------|
| Panel size | 169(H) X 169(V) | mm | |
| CF size | 166.91(H) X164.992(V) | mm | |
| Active area | 157.824(H) × 157.824(V) | mm | |
| Number of pixels | 768(H) RGB×768(V) | pixels | |
| | (1 pixel = R + G + B dots) | | |
| Pixel pitch | 205.5(H) × 205.5(V) | um | |
| Pixel arrangement | RGB 2 domain stripe | | |
| Dimensional outline | 169(H)×169(V)×1.287(D) | mm | OC |
| Display mode | Normally Black | | |

9.2 Mounting

See FIG.5.

9.3 Glare and Polarizer Hardness

The surface of the LCD has a hard coating to reduce scratching.

Figure 5. Open Cell Outline Dimensions (unit: mm if unspecified)

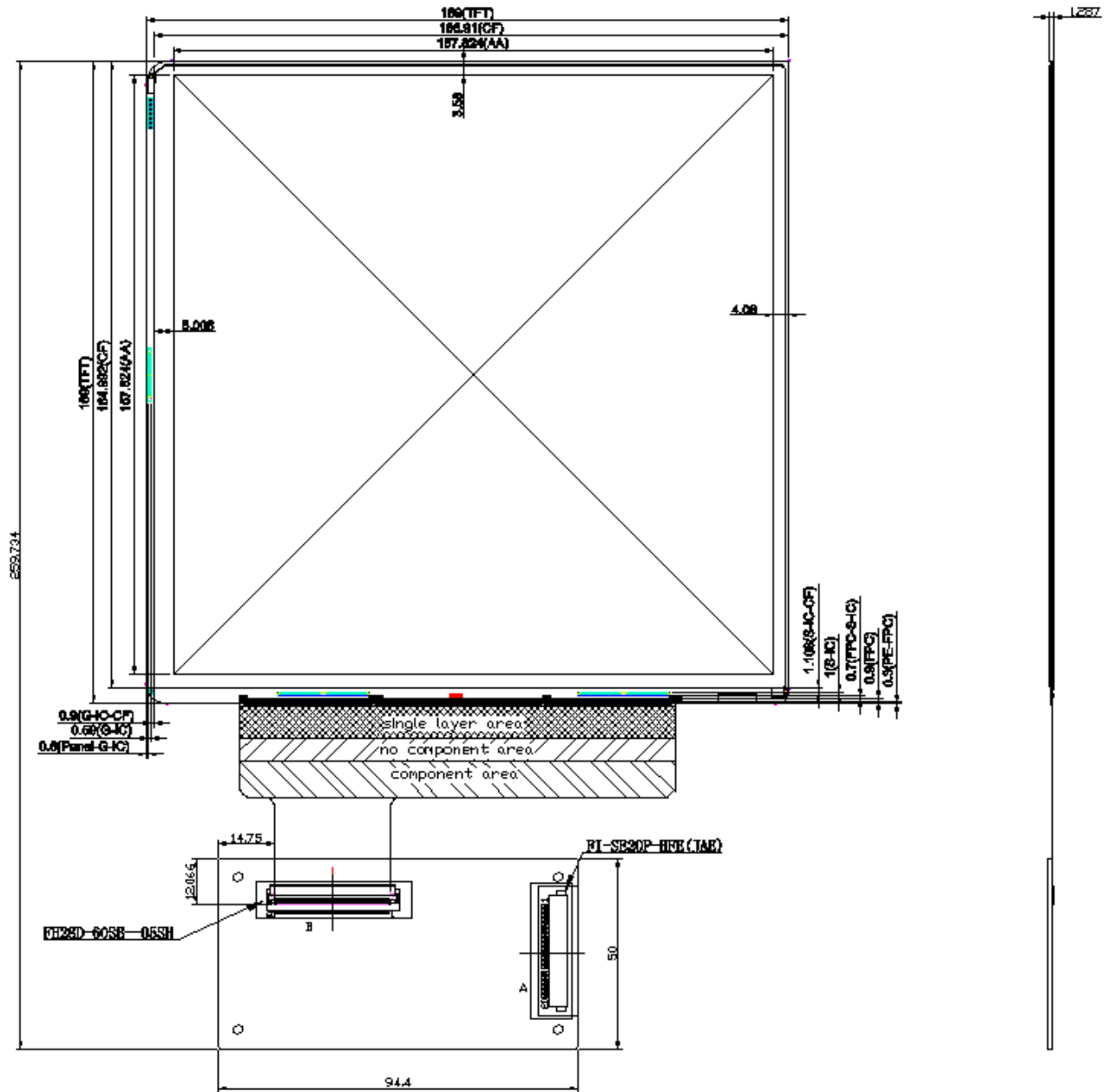

10.0 RELIABILITY TEST

| NO | Test Item | Test Condition | Duration |
|----|---|---|-----------|
| 1 | Low temperature storage test(LTS) | -55℃ | 24hrs |
| | Low temperature operation test(LTO) | -40 ℃ | 2hrs |
| | High temperature storage test(HTS) | 85 ℃ | 48hrs |
| | High temperature operation test(HTO) | 85 ℃ | 2hrs |
| 2 | Thermal shock test (TST) | 85 ℃: hold for 0.5hr -55 ℃: hold for 0.5hr | 10 cycles |
| | High temperature, high humidity storage test(THS) | 30℃~60℃, 95% | 240hrs |
| 3 | High temperature operation test(HTO) | 85 ℃ | 240hrs |

11.0 PACKING

11.1 Tray

The outline of tray is 450mm*370mm, as is shown in Fig8. Package two products with antistatic spacers and trays with the method shown in Fig9.

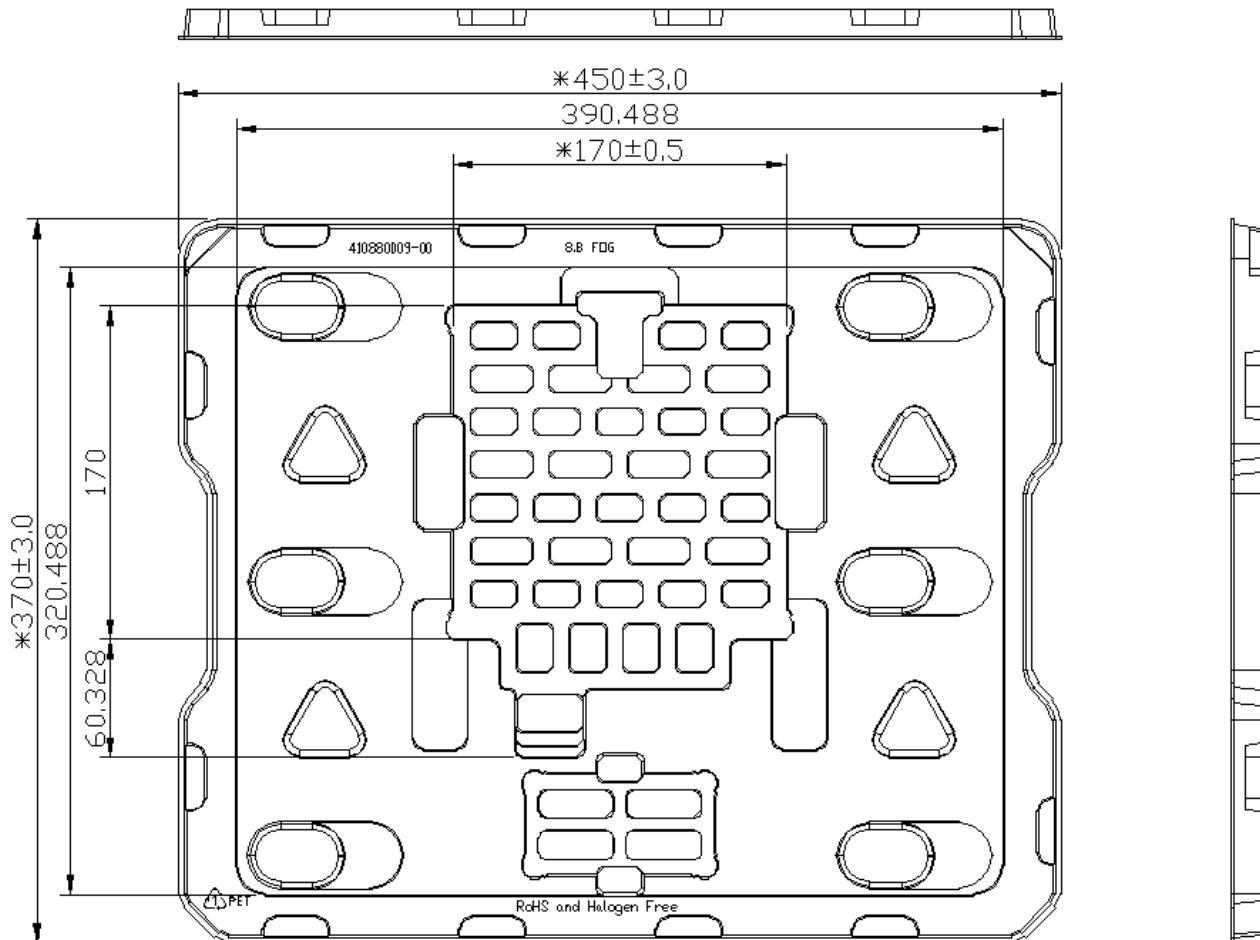

Fig 8

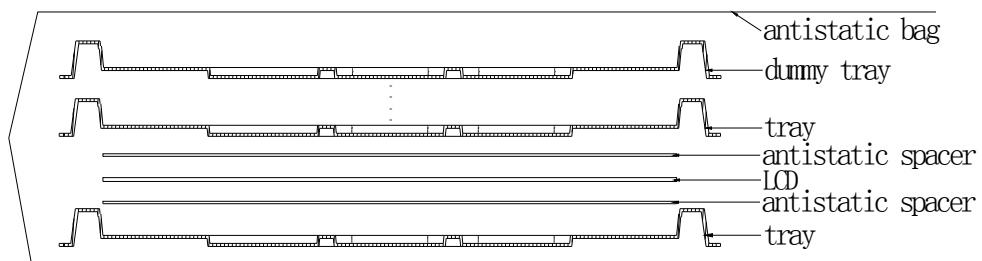

Fig 9

11.2 Little carton

Put four Corner EPE and two Up-down EPE around the products. Then put all of them in one little carton. The dimension of little carton is about 520(L)*440(W)*115(H)mm.

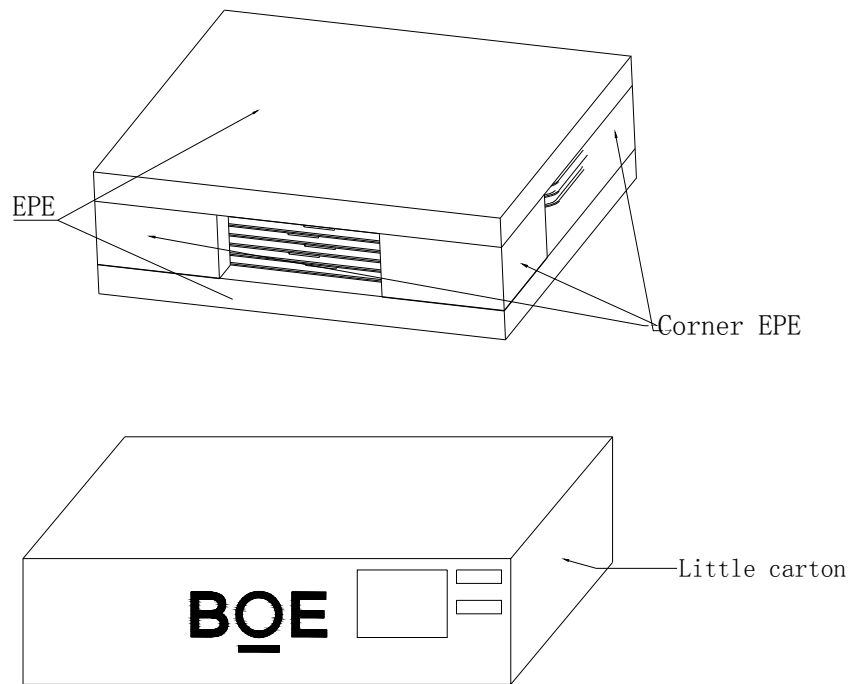

Fig 10

11.3 Big carton

Put four little cartons in one big carton. So there are eight LCD in one big carton totally. The dimension of big carton is about 545(L)*465(W)*500(H)mm.

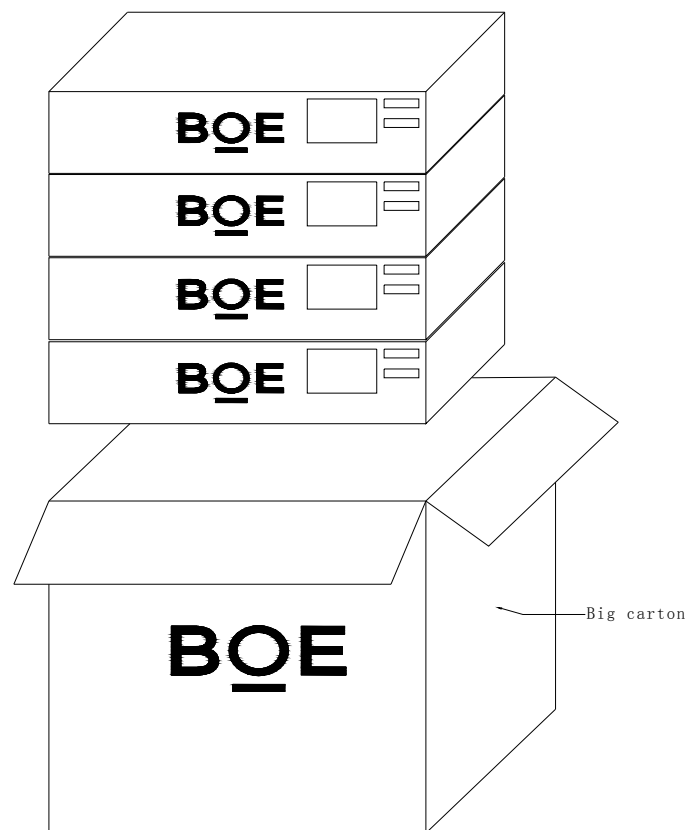

Fig 11

11.4 Packing Notice

- Panel should be placed upwardly while in the box.
- Every spacer should be put under every panel.
- Panels should be packed in a vacuum with PE (anti-ESD) bag.

12.0 Handling & Cautions

12.1 Mounting Method

- The panel of the LCD consists of two thin glasses with polarizers which easily get damaged. So extreme care should be taken when handling the LCD.
- Excessive stress or pressure on the glass of the LCD should be avoided. Care must be taken to insure that no torsional or compressive forces are applied to the LCD unit when it is mounted.
- If the customer's set presses the main parts of the LCD, the LCD may show the abnormal display. But this phenomenon does not mean the malfunction of the LCD and should be pressed by the way of mutual agreement.
- To determine the optimum mounting angle, refer to the viewing angle range in the specification for each model.
- Mount a LCD module with the specified mounting parts.

12.2 Caution of LCD Handling and Cleaning

- Since the LCD is made of glass, do not apply strong mechanical impact or static load onto it. Handling with care since shock, vibration, and careless handling may seriously affect the product. If it falls from a high place or receives a strong shock, the glass maybe broken.
- The polarizer on the surface of panel are made from organic substances. Be very careful for chemicals not to touch the polarizer or it leads the polarizer to be deteriorated.
- If the use of a chemical is unavoidable, use soft cloth with solvent (recommended below) to clean the LCD's surface with wipe lightly.
-IPA (Isopropyl Alcohol), Ethyl Alcohol, Tri-chloro, tri-florothane..
- Do not wipe the LCD's surface with dry or hard materials that will damage the polarizer, And others, Do not use the following solvent.
-Water, acetone, Aromatics.
- It is recommended that the LCD be handled with soft gloves during assembly, etc. The polarizer on the LCD's surface are vulnerable to scratch and thus to be damaged by shape particles.
- Do not drop water or any chemicals onto the LCD's surface.
- A protective film is supplied on the LCD and should be left in place until the LCD is required for operation.
- The ITO pad area needs special careful caution because it could be easily corroded. Do not contact the ITO pad area with HCFC, Soldering flux, Chlorine, Sulfur, saliva or fingerprint. To prevent from the ITO corrosion, customers are recommended that the ITO area would be covered by UV or silicon.
- Please clean the LCD without ultrasonic to avoid line open

12.3 Caution Against Static Charge

- The LCD modules use C-MOS LSI drivers, so customers are recommended that any unused

input terminal would be connected to Vdd or Vss, do not input any signals before power is turn on, and ground you body, work/assembly area, assembly equipments to protect against static electricity.

- Remove the protective film slowly, keeping the removing direction approximate 30-degree not vertical from panel surface, if possible, under ESD control device like ion blower, and the humidity of working room should be kept over 50%RH to reduce the risk of static charge.
- Avoid the use work clothing made of synthetic fibers. We recommend cotton clothing or other conductivity-treated fibers.
- In handling the LCD, wear non-charged material gloves. And the conducting wrist to the earth and the conducting shoes to the earth are necessary.

12.4 Caution For operation

- It is indispensable to drive the LCD within the specified voltage limit since the higher voltage than the limit causes the shorter LCD's life. An electro-chemical reaction due to DC causes undesirable deterioration of the LCD so that the use of DC drive should avoid.
- Do not connect or disconnect the LCD to or from the system when power is on.
- Never use the LCD under abnormal conditions of high temperature and high humidity.
- When expose to drastic fluctuation of temperature(hot to cold or cold to hot) ,the LCD may be affected; specifically, drastic temperature fluctuation from cold to hot, produces dew on the LCD's surface which may affect the operation of the polarizer and the LCD.
- Response time will be extremely delayed at lower temperature than the operating temperature range and on the other hand at higher temperature LCD may turn black at temperature above its operational range. However those phenomena do not mean malfunction or out of order with the LCD. The LCD will revert to normal operation once the temperature returns to the recommended temperature range for normal operation.
- Do not display the fixed pattern for a long time because it may develop image sticking due to the LCD structure. If the screen is displayed with fixed pattern, use a screen saver.

12.5 Packaging

- Modules use LCD element, and must be treated as such.
- Avoid intense shock and falls from a height.
- To prevent modules from degradation, do not operate or store them exposed directly to sunshine or high temperature/humidity for long periods.

12.6 Storage

- A slight dew depositing on terminals is a cause for electro-chemical reaction resulting in terminal open circuit. Relative humidity of the environment should therefore be kept below 60%RH.
- Original protective film should be used on LCD's surface (polarizer). Adhesive type protective film should be avoided, because it may change color and/or properties of the polarizer.
- Do not store the LCD near organic solvents or corrosive gasses.

- Keep the LCD safe from vibration, shock and pressure.
- Black or white air-bubbles may be produced if the LCD is stored for long time in the lower temperature or mechanical shocks are applied onto the LCD.
- In the case of storing for a long period of time for the purpose or replacement use, the following ways are recommended.
 - Store in a polyethylene bag with sealed so as not to enter fresh air outside in it.
 - Store in a dark place where neither exposure to direct sunlight nor light is.
 - Keep temperature in the specified storage temperature range.
 - Store with no touch on polarizer surface by the anything else. If possible, store the LCD in the packaging situation LCD when it was delivered.

12.7 Safety

- For the crash damaged or unnecessary LCD, it is recommended to wash off liquid crystal by either of solvents such as acetone and ethanol and should be burned up later.
- In the case the LCD is broken, watch out whether liquid crystal leaks out or not. If your hands touch the liquid crystal, wash your hands cleanly with water and soap as soon as possible.
- If you should swallow the liquid crystal, first, wash your mouth thoroughly with water, then drink a lot of water and induce vomiting, and then, consult a physician.
- If the liquid crystal gets in your eyes, flush your eyes with running water for at least fifteen minutes.
- If the liquid crystal touches your skin or clothes, remove it and wash the affected part of your skin or clothes with soap and running water.