

Description

The DFI450HF12DF1 offer lower losses and higher energy for soft switching application.



Features

- 1200V450 A, $V_{CE(sat)}(typ.) = 1.95V$
- Low inductive design
- Lower losses and higher energy
- Excellent short circuit ruggedness
- Field Stop IGBT Technology

Applications

- Motor drive
- Inverter
- Power supply

Circuit diagram

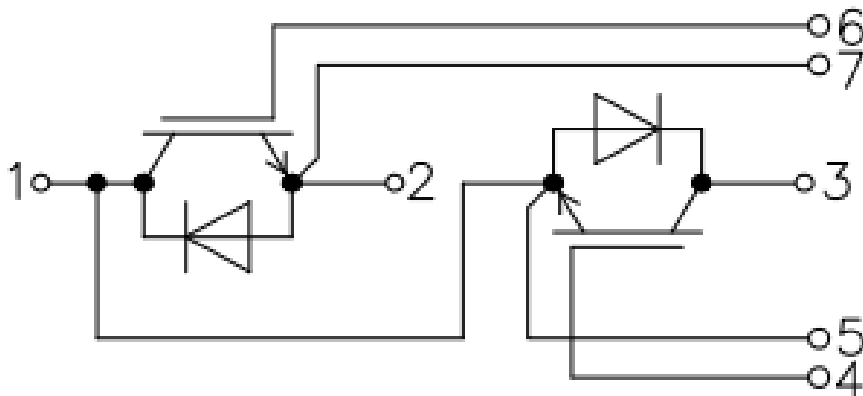

Figure 1. Out drawing & circuit diagram for DFI450HF12DF1

Pin Configuration and Marking Information

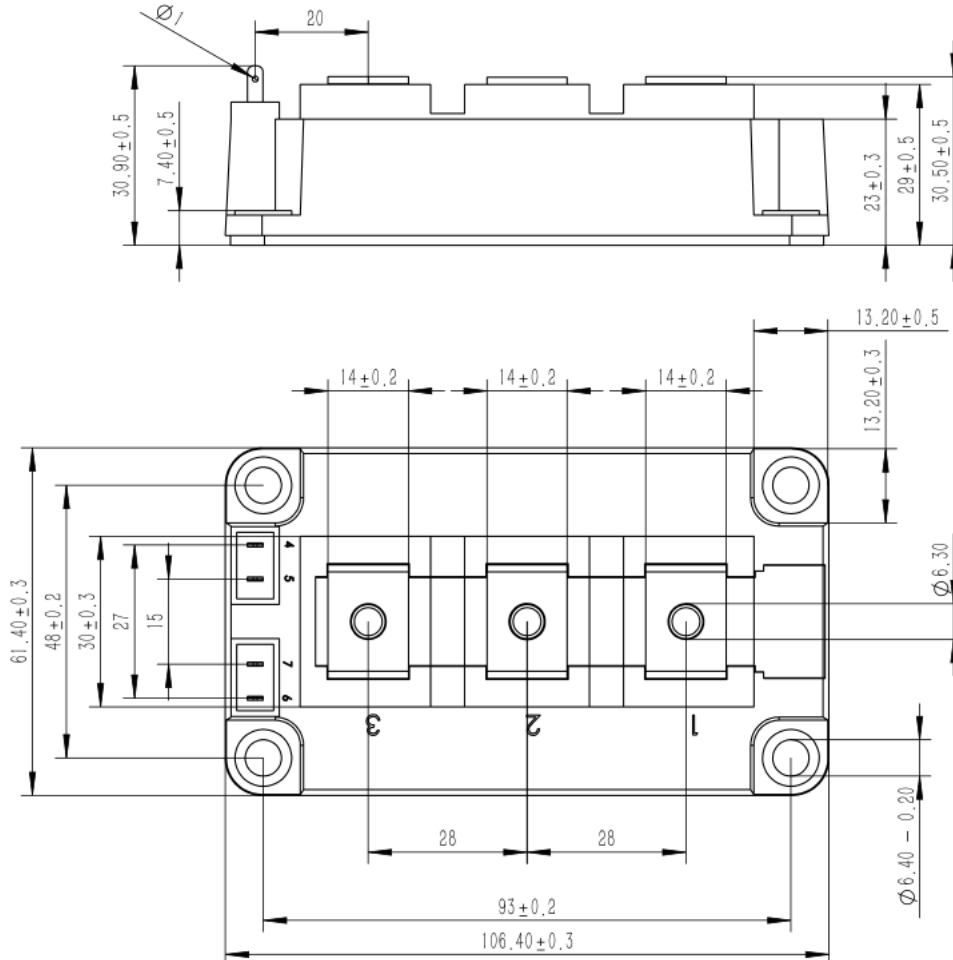

Figure 2. Pin configuration

Module

Parameter	Conditions	Value	Unit
Isolation Voltage	RMS, f = 50Hz, t = 1min	4.0	KV
Material of module baseplate	-	Cu	-
Creepage distance	terminal to heatsink terminal to terminal	14.5 13	mm
Clearance	terminal to heatsink terminal to terminal	12.5 10	mm
CTI	-	>200	-
Module lead resistance, terminals – chip	T _C = 25°C	0.8	mΩ
Mounting torque for module mounting	M6	3 to 6	Nm
Weight	-	315	g

Maximum Ratings (IGBT, $T_j=25^{\circ}\text{C}$ unless otherwise specified)

Symbol	Parameter	Conditions	Ratings	Unit
V_{CES}	Collector-Emitter Voltage	G-E Short	1200	V
V_{GES}	Gate-Emitter Voltage	C-E Short	$\pm 30\text{V}$	V
I_C	DC Continuous Collector Current	$T_C=100^{\circ}\text{C}$	450	A
I_{CM}	Pulse Collector Current	$t_p=1\text{ms}$, Note1	900	A
P_C	Maximum Power Dissipation	$T_C=25^{\circ}\text{C}$, $T_j=150^{\circ}\text{C}$ (IGBT)	1420	W
T_j	junction temperature	-	-40 to 150	$^{\circ}\text{C}$
T_{stg}	Storage temperature	-	-40 to 125	$^{\circ}\text{C}$

Note1: Pulse width limited by maximum junction temperature

Maximum Ratings (Freewheeling diode, $T_j=25^{\circ}\text{C}$ unless otherwise specified)

Symbol	Parameter	Conditions	Ratings	Unit
V_{RRM}	Peak Repetitive Revers Voltage	-	1200	V
I_F	Diode forward Current	- $T_j=150^{\circ}\text{C}$	450	A
I_{FRM}	Repetitive peak forward Current	$t_p=1\text{ms}$, Note1	900	A
T_j	junction temperature	-	-40 to 150	$^{\circ}\text{C}$
T_{stg}	Storage temperature	-	-40 to 125	$^{\circ}\text{C}$

Note1: Pulse width limited by maximum junction temperature

IGBT Electrical characteristics ($T_j=25^{\circ}\text{C}$ unless otherwise specified, chip)

Symbol	Item	Condition	Value			Unit	
			Min.	Typ.	Max		
$V_{CE(sat)}$ (Chip)	Collector-Emitter Saturation Voltage	$I_C=450\text{A}$ $V_{GE}=15\text{V}$	$T_j=25^{\circ}\text{C}$	-	1.95	2.20	V
			$T_j=125^{\circ}\text{C}$	-	2.20	-	V
$V_{GE(th)}$	Gate-Emitter threshold Voltage	$I_C=15\text{mA}$, $V_{CE}=V_{GE}$	5.0	-	6.0	V	
Q_G	Gate charge	$V_{GE}=-15\text{V}$ to $+15\text{V}$	-	2.6	-	μC	
R_{Gint}	Internal gate resistor	$f=1\text{M}$, $V_{pp}=1\text{V}$	$T_j=25^{\circ}\text{C}$	-	3.9	-	Ω
C_{ies}	Input Capacitance	$V_{CE}=25\text{V}$, $V_{GE}=0\text{V}$ $f=1\text{MHz}$	$T_j=25^{\circ}\text{C}$	-	38	-	nF
C_{oes}	Output Capacitance			-	3.3	-	nF
C_{res}	Reverse transfer Capacitance			-	1.7	-	nF
I_{CES}	Collector- Emitter Cut off Current	$V_{CE}=1200\text{V}$, $V_{GE}=0\text{V}$	$T_j=25^{\circ}\text{C}$	-	-	3	mA
I_{GES}	Gate-Emitter Leakage Current	$V_{GE}=30\text{V}$, $V_{CE}=0\text{V}$	$T_j=25^{\circ}\text{C}$	-	-	400	nA
$t_{d(on)}$	Turn-on delay time		$T_j=25^{\circ}\text{C}$	-	360	-	ns
			$T_j=125^{\circ}\text{C}$	-	395	-	
t_r	Rise time		$T_j=25^{\circ}\text{C}$	-	110	-	ns
			$T_j=125^{\circ}\text{C}$	-	118	-	
$t_{d(off)}$	Turn-off delay time		$T_j=25^{\circ}\text{C}$	-	750	-	ns
			$T_j=125^{\circ}\text{C}$	-	810	-	

t _f	Fall time	V _{CC} = 600V	T _j = 25°C	-	92	-	ns
			T _j = 125°C	-	101	-	
E _{on}	Turn-on power dissipation	I _C = 450A V _{GE} = +15V/-15V	T _j = 25°C	-	59	-	mJ
			T _j = 125°C	-	69	-	
E _{off}	Turn-off power dissipation	R _G = 3Ω Inductive load	T _j = 25°C	-	45	-	mJ
			T _j = 125°C	-	58	-	
R _{th(j-c)}	Thermal Resistance, Junction to Case (IGBT)		-	-	0.088	-	°C/W

Freewheeling Diode Electrical characteristics (T_j = 25°C unless otherwise specified, chip)

Symbol	Item	Condition	Value			Unit	
			Min.	Typ.	Max		
V _F	Diode Forward Voltage	I _F = 450A, V _{GE} = 0V	T _j = 25°C	-	2.0	2.2	V
			T _j = 125°C	-	2.1	-	
I _{rr}	Peak reverse recovery Current	I _F = 450A, di/dt = 5000A/μs, V _R = 600V, V _{GE} = -15V	T _j = 25°C	-	280	-	A
			T _j = 125°C	-	330	-	
Q _{rr}	Recovered charge	V _R = 600V, V _{GE} = -15V	T _j = 25°C	-	25	-	nC
			T _j = 125°C	-	44	-	
E _{rr}	Reverse recovered energy	V _R = 600V, V _{GE} = -15V	T _j = 25°C	-	11	-	mJ
			T _j = 125°C	-	18	-	
R _{th(j-c)}	Thermal Resistance, Junction to Case (Diode)		-	-	0.10	-	°C/W

Test Conditions

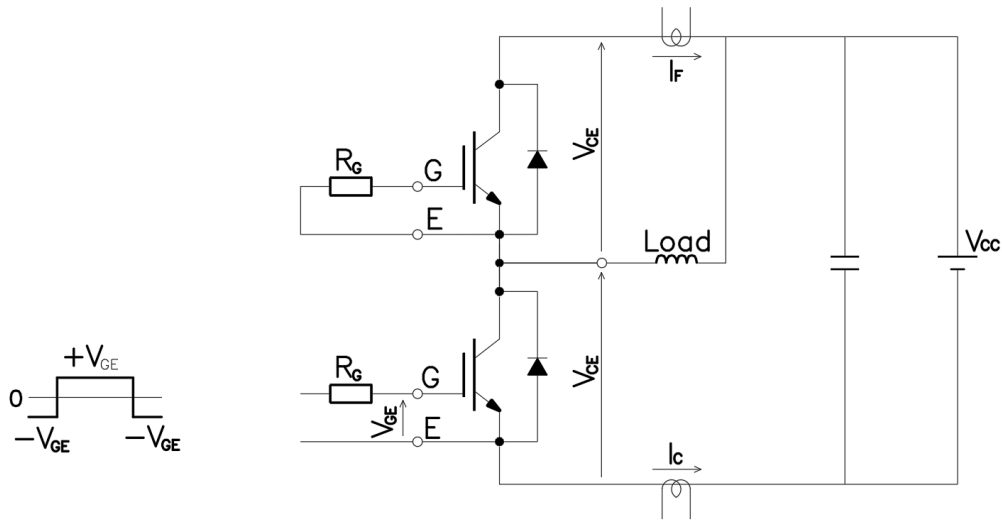

Figure 3. Switching time measure circuit

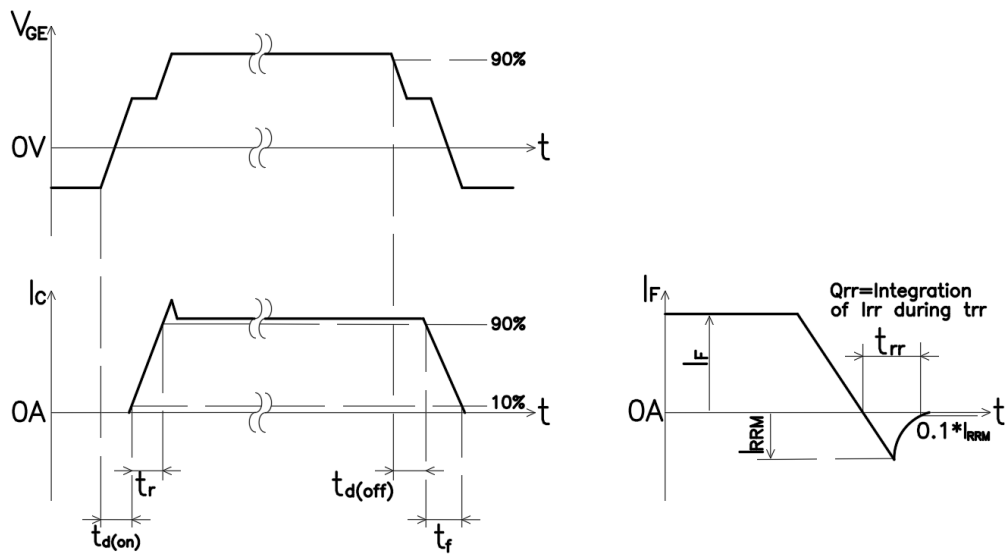

Figure 4. Switching time definition

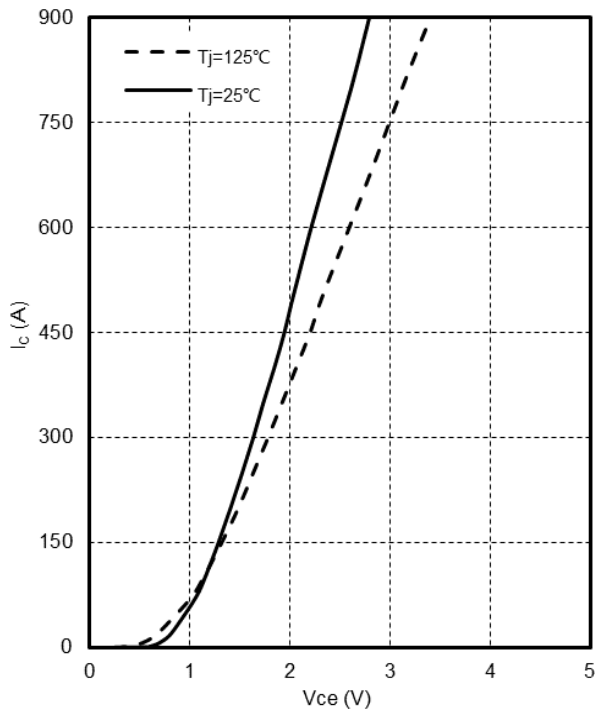

Figure 5. I_c vs V_{ce}
 $V_{GE}=15\text{V}$

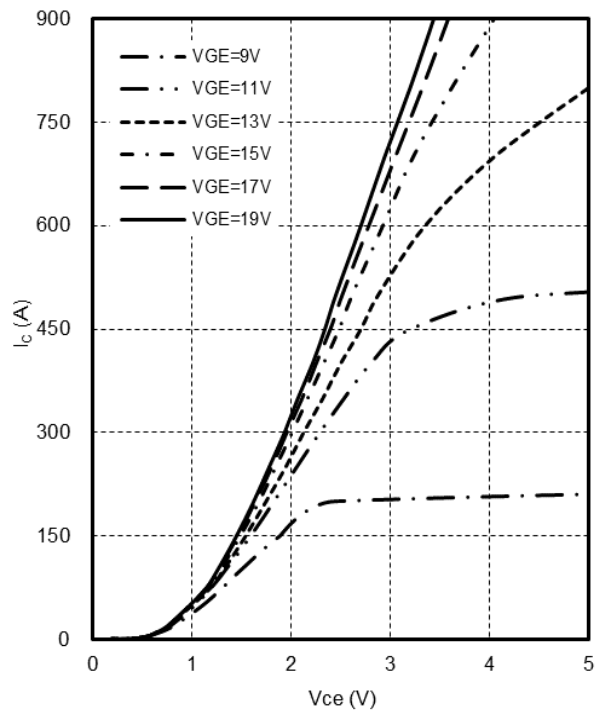

Figure 6. I_c vs V_{ce}
 $T_j=125^\circ\text{C}$

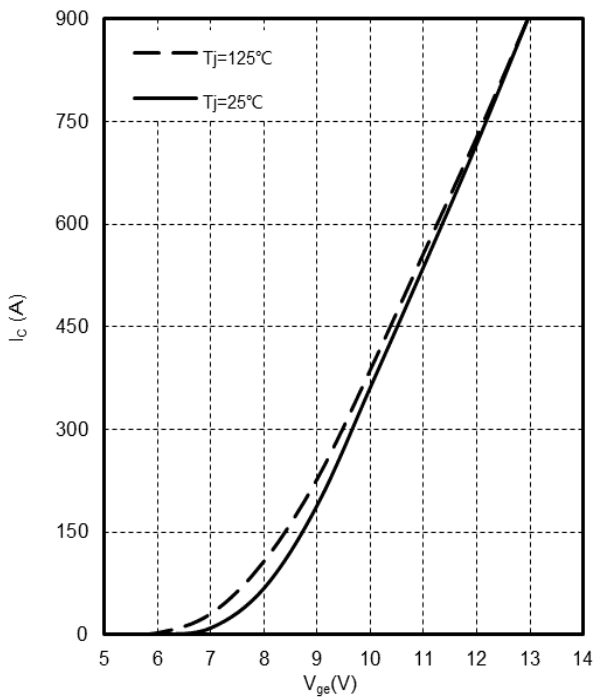

Figure 7. I_c vs V_{GE}
 $V_{CE}=20\text{V}$

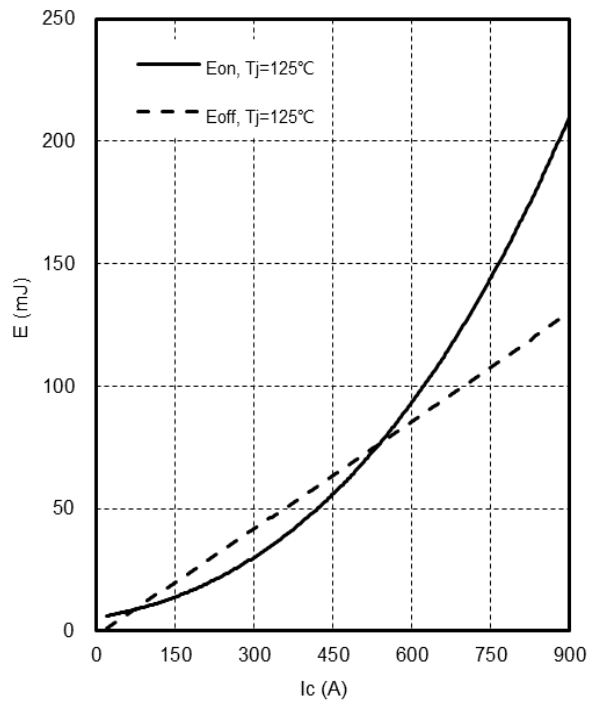

Figure 8. E_{on} , E_{off} vs I_c (Typ)
 $V_{CC}=600\text{V}$, $V_{GE}=+15\text{V}/-15\text{V}$, $R_G=3\Omega$
Inductive Load

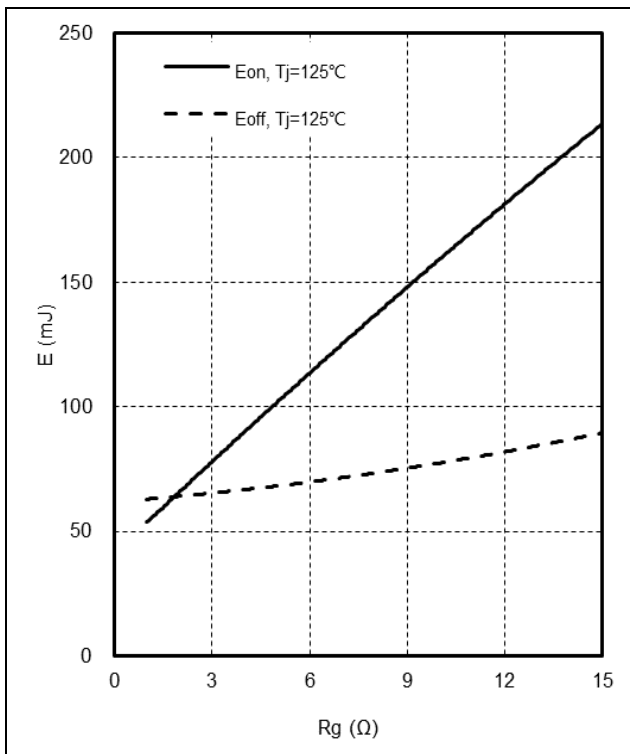

Figure 9. E_{on} , E_{off} vs R_g (Typ)
 $V_{CC}=600V$, $V_{GE}=+15V/-15V$, $I_C=450A$
 Inductive Load

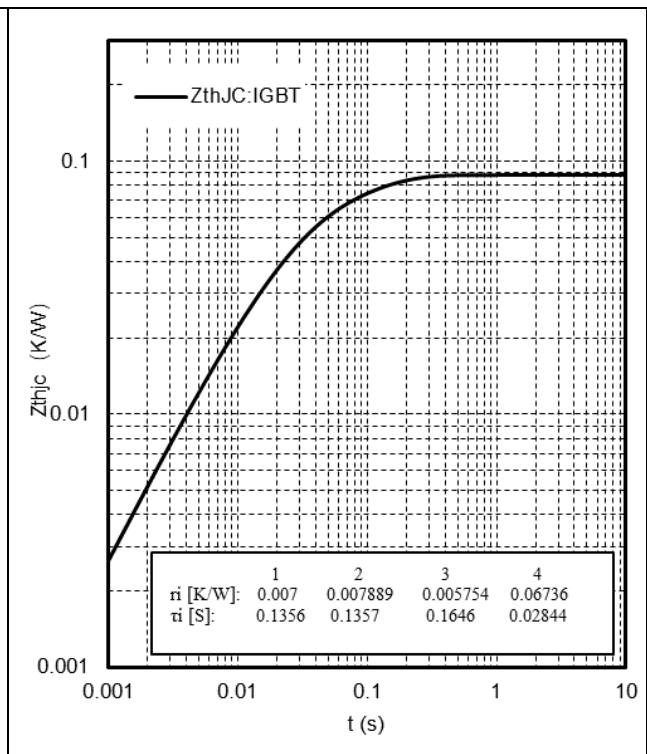

Figure 10. Transient thermal impedance IGBT ,
 $Z_{thjc}=f(t)$

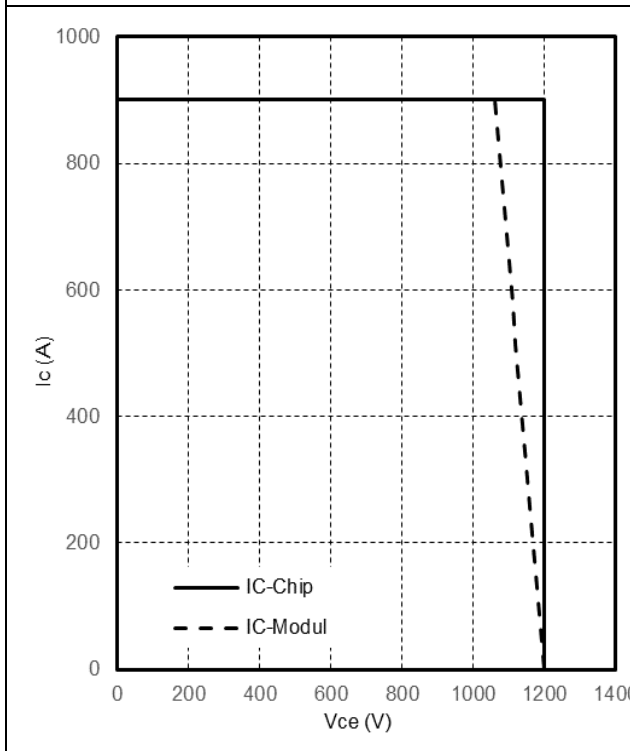

Figure 11. Reverse bias safe operating area IGBT,
 $I_C=f(V_{CE})$, $V_{GE}=\pm 15V$, $R_{Goff}=3\Omega$, $T_{vj}=125^\circ C$

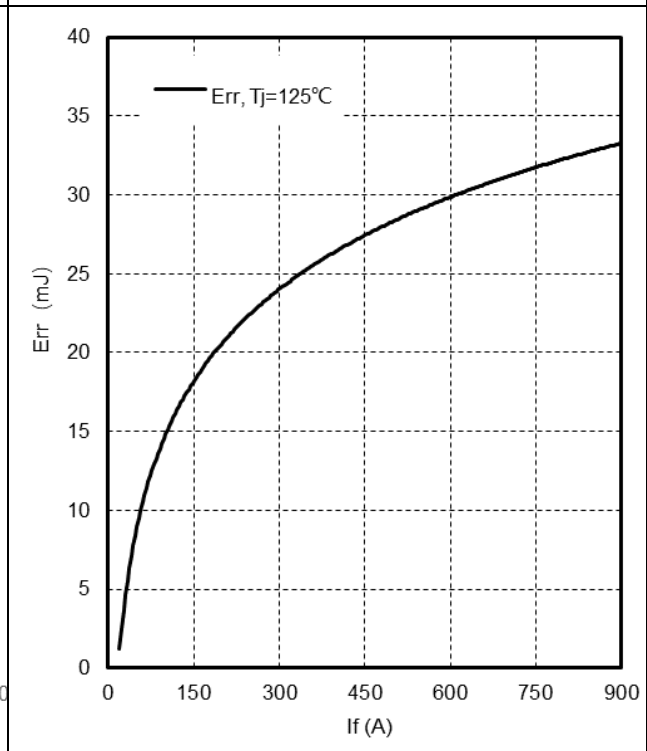

Figure 12. E_{rr} vs I_F (Typ)
 $V_{CC}=600V$, $V_{GE}=+15V/-15V$, $R_G=3\Omega$
 Inductive Load

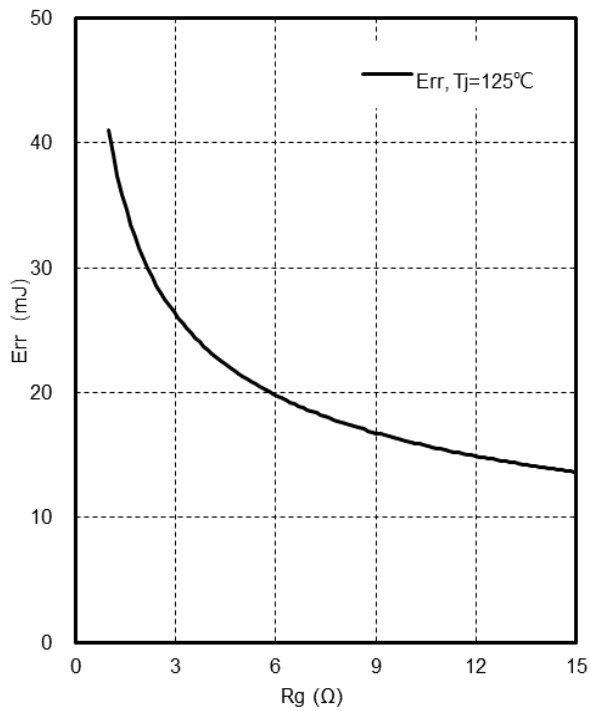

Figure 13. Err vs R_G (Typ)
 $V_{CC}=600V$, $V_{GE}=+15V/-15V$, $I_F=450A$
 Inductive Load

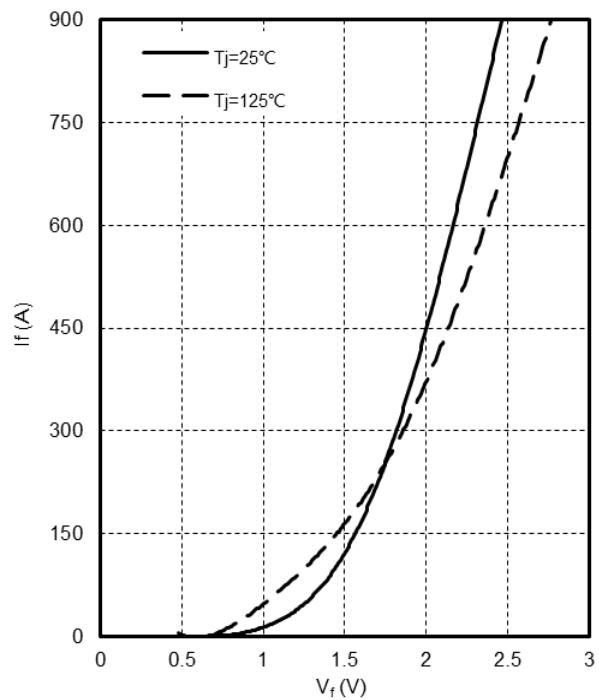

Figure 14. Forward characteristic of Diode ,
 $I_F=f(V_F)$

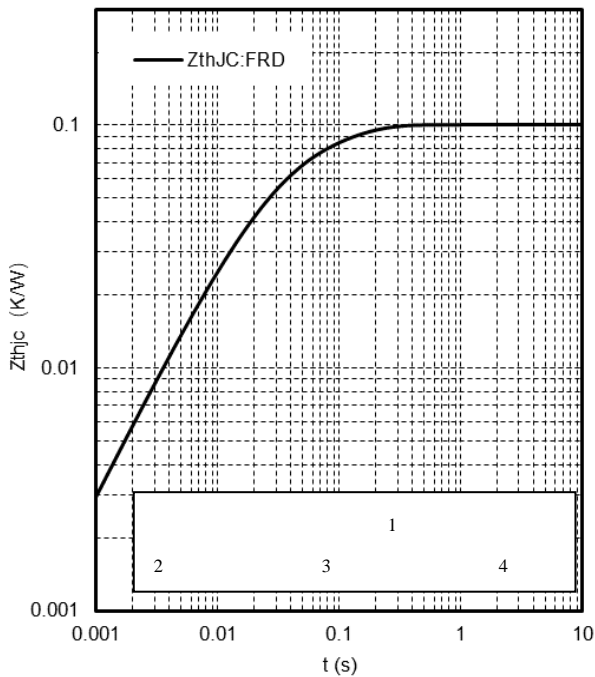

Figure 15. Transient thermal impedance Diode,
 $Z_{thjc}=f(t)$

IMPORTANT NOTICE:

This product data sheet describes the characteristics of this product for which a warranty is granted. Any such warranty is granted exclusively under the terms and conditions of the supply agreement. There will be no guarantee or of any kind for the product and its characteristics.

The data contained in this document is exclusively intended for technically trained staff. You and your technical departments will have to evaluate the product's suitability for the intended application and the completeness of the product data concerning such application.

Due to technical requirements, our product may contain dangerous substances. For information on the types in question, please contact the sales staff responsible for you.

Changes to this product data sheet are reserved.

Please contact the sales staff (Sales@leapers-power.com) for further information on the product, technology, delivery terms, conditions and prices.