

ZXP3010GDS Gauge Pressure Sensor With I²C/SPI

(Ver A1.0)

● DESCRIPTION

The ZXP3010GDS is the pressure sensor which measures gauge pressures. It consists of a silicon micro-machined sensing element chip and a signal conditioning ASIC. The ASIC is equipped with a 24-bit resolution $\Sigma-\Delta$ ADC and outputs a highly precise pressure value as a digital value. The pressure sensor element and the ASIC are mounted inside a system-in-package and wire-bonded to appropriate contacts. The ZXP3010GDS provides digital output interface. It can achieve ESD robustness, fast response time, high accuracy and linearity as well as long-term stability. All measurement data is fully calibrated and temperature compensated. In addition, it allows for easy system integration.

● FEATURES

- Piezo-resistive silicon micro-machined sensor
- Gauge type pressure sensor
- I²C / SPI Interface
- Pressure range: +/- 10000 Pa
- 24 Bit $\Sigma-\Delta$ ADC
- Temperature Compensation: 0 ~ 60°C
- Operating voltage 3.0V
- Operating mode current: ~1.5mA (typical)
- Sleep Mode current: 20nA (typical)
- SOP6 package



● APPLICATIONS

- Medical instrumentation
- Industrial pneumatic control
- Air Conditioning

- HVAC Application
- Home electricity appliances

● Block Diagram

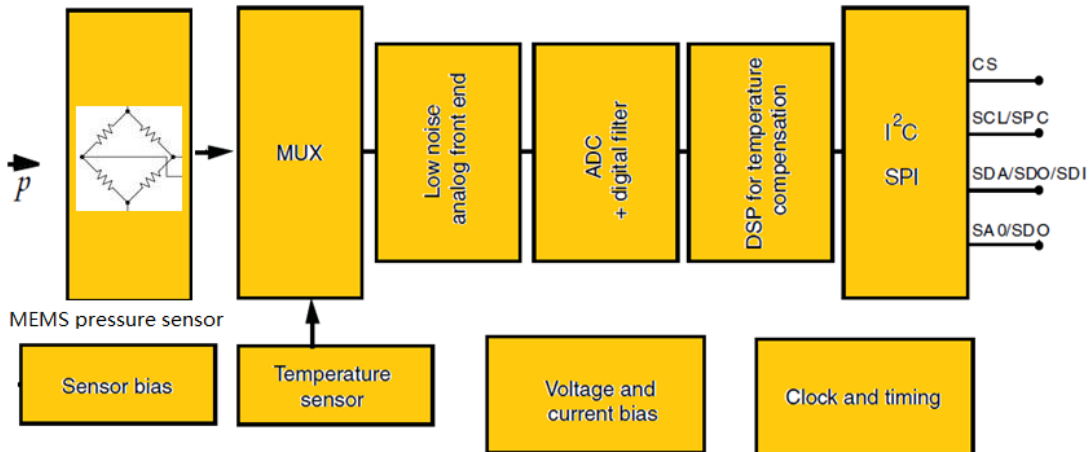

● Pin Configuration

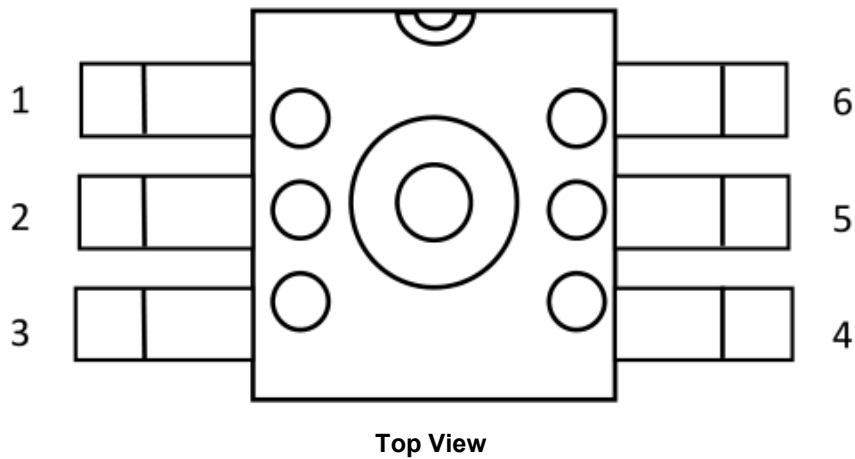

● Pin Description

Pin No.	Pin Name	I/O	Function description
1	VDD	P	Positive supply voltage
2	CSB	I	I ² C/SPI mode select: Pulling 'CSB' pin low selects the SPI interface, leaving 'CSB' pin float or pulling it high selects the I ² C interface.
3	SDA/SDI	I/O	Data in/out for I ² C. Data input for SPI.
4	SCL/SCK	I	Clock input for I ² C/SPI
5	SDO/ADDR	O	Data output for SPI I ² C mode The LSB bit of the 7bits device address is configured
6	GND	P	Connected to GND

● Maximum Ratings

Voltage with respect to GND unless otherwise noted.

Characteristic	Minimum	Typical	Maximum	Units
Supply Voltage	0		6	V
Operating Temperature	-40		85	°C
Storage Temperature	-40	—	125	°C

● Specification

Electrical Characteristics

Characteristic	Minimum	Typical	Maximum	Units
Operating Voltage	1.8	3.3	3.6	V
Operating Current		1.5		mA
Standby Current		100		nA
Proof pressure			50	KPa
Pressure Range	-10		10	KPa
Accuracy	-1		1	%FS
ADC Resolution		24		bit
I ² C Clock Frequency			400	KHz
SPI Clock Frequency			10	MHz
Compensated Temperature	0		60	°C

Range				
-------	--	--	--	--

● NORMAL REGISTERS

地址	描述	RW	Bit7	Bit6	Bit5	Bit4	Bit3	Bit2	Bit1	Bit0	默认值
0x00	SPI_Ctrl	R/W	SDO_active	LSB_first	Soft_reset			Soft_reset	LSB_first	SDO_active	0x00
0x06	DATA_MSB	R	Data_out<23:16>								0x00
0x07	DATA_CSB	R	Data_out<15:8>								0x00
0x08	DATA_LSB	R	Temp_out<7:0>								0x00
0x09	TEMP_MSB	R	Temp_out<15:8>								0x00
0x0A	TEMP_LSB	R	Temp_out<7:0>								0x00
0x30	CMD	RW	Sleep_time<3:0>			Sc0	Measurement_ctrl<2:0>			0x00	
0xA5	Sys_config	RW							Raw_data_on	DIAG_on	OTP

Reg0x00

SDO_active: 1: 4-wire SPI, 0: 3-wire SPI

LSB_first: 1: LSB first for SPI interface, 0: MSB first for SPI interface

Soft_reset: 1: Reset all the NSA2300 registers (except 'margin'), automatically come back to 0 after reset complete.

Reg0x06-Reg0x08

Data_out: 24 bits ADC output data when 'raw_data_on' = 0 with an LSB equals to $(1/2^{23}) * V_{EXT}$. 24 bits calibrated data when 'raw_data_on' = 1.

Reg0x09-Reg0x0a

Temp_out: Temperature output with an LSB equals to $(1/256) ^\circ C$

Reg0x30

Sleep_time<3:0>: 0000:0ms, 0001:62.5ms, 0010:125ms ... 1111: 1s, only active during sleep mode conversion.

Measurement_control<1:0>: 000b, indicate a single shot temperature signal conversion. 001b, indicate a single shot sensor signal conversion. 010b: indicate a combined conversion (once temperature conversion immediately followed by once sensor signal conversion). 011b: indicate a sleep mode conversion (periodically perform once combined conversion with an interval time of 'sleep_time'), 100b: OTP programming mode, enter this mode to when programming OTP banks.

Sc0: 1, Start of conversion, automatically come back to 0 after conversion ends (except sleep mode conversion).

Reg0xA5

Raw_data_on: 0: output calibrated data, 1: output ADC raw data. (Only take effect in single shot sensor signal conversion and single shot temperature conversion)

Diag_on: 1, Enable diagnosis function.

● SPI INTERFACE

ZXP3010GDS provides both SPI and I²C interface for serial communication and ‘CSB’ pin is used to switch between these two protocols. Pulling ‘CSB’ pin low selects the SPI interface, leaving ‘CSB’ pin float or pulling it high selects the I²C interface.

INTERFACE SPECIFICATION

SPI interface specifications

Parameter	Symbol	Condition	Min	Max	Unit
Clock frequency	f_{sclk}	Max load on SDIO or SD0 = 25p		10	MHz
SLCK low pulse	t_{sclk_l}		20		ns
SLCK high pulse condition	t_{sclk_h}		20		
SDI setup time	T_{sdi_setup}		20		ns
SDI hold time	T_{sdi_hold}		20		ns
SDO/SDI output delay	T_{sdo_od}	Load = 25pF		30	ns
		Load = 250pF		40	
CSB setup time	T_{csb_setup}		20		ns
CSB hold time	T_{csb_hold}		40		ns

The figure below shows the definition of the SPI timing given in table.

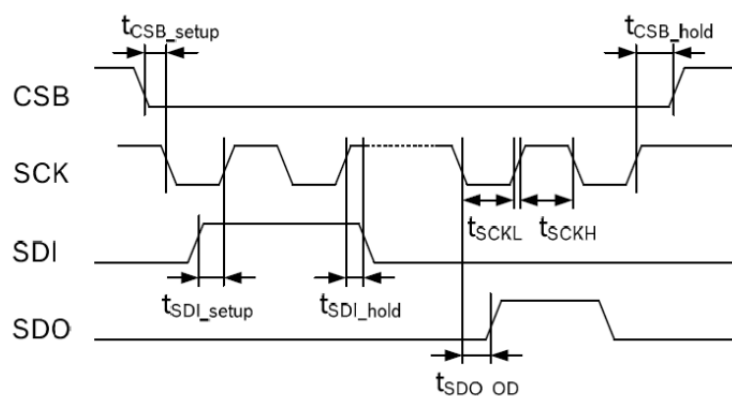

SPI timing diagram

The falling edge of CSB, in conjunction with the rising edge of SCLK, determines the start of framing. Once the beginning of the frame has been determined, timing is straightforward. The first phase of the transfer is the instruction phase,

which consists of 16 bits followed by data that can be of variable lengths in multiples of 8 bits. If the device is configured with CSB tied low, framing begins with the first rising edge of SCLK.

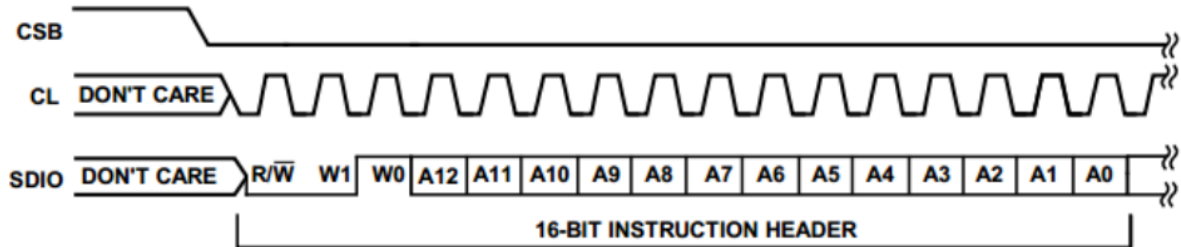

Instruction Phase Bit Field

The first bit in the stream is the read/write indicator bit (R/W). When this bit is high, a read is being requested, otherwise indicates it is a write operation.

W1 and W0 represent the number of data bytes to transfer for either read or write. If the number of bytes to transfer is three or less (00, 01, or 10), CSB can stall high on byte boundaries. Stalling on a nonbyte boundary terminates the communications cycle. If these bits are 11, data can be transferred until CSB transitions high. CSB is not allowed to stall during the streaming process. The remaining 13 bits represent the starting address of the data sent. If more than one word is being sent, sequential addressing is used, starting with the one specified, and it either increments (LSB first) or decrements (MSB first) based on the mode setting.

Table W1 and W0 settings

W1:W0	Action	CSB stalling
00	1 byte of data can be transferred.	Optional
01	2 bytes of data can be transferred.	Optional
10	3 bytes of data can be transferred.	Optional
11	4 or more bytes of data can be transferred. CSB must be held low for entire sequence; otherwise, the cycle is terminated.	NO

Data follows the instruction phase. The amount of data sent is determined by the word length (Bit W0 and Bit W1). This can be one or more bytes of data. All data is composed of 8-bit words.

Data can be sent in either MSB-first mode or LSB-first mode (by setting 'LSB_first' bit). On power up, MSB-first mode is the default. This can be changed by programming the configuration register. In MSB-first mode, the serial exchange starts with the highest-order bit and ends with the LSB. In LSB-first mode, the order is reversed.

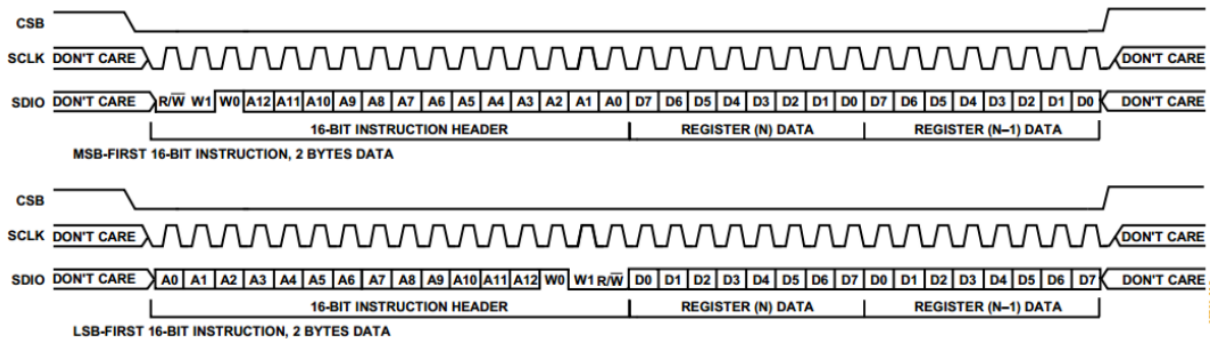

MSB First and LSB First Instruction and Data Phases

Register bit ‘SD0_active’ is responsible for activating SD0 on devices. If this bit is cleared, then SD0 is inactive and read data is routed to the SDIO pin. If this bit is set, read data is placed on the SD0 pin. The default for this bit is low, making SD0 inactive.

● I²C INTERFACE

I²C bus uses SCL and SDA as signal lines. Both lines are connected to VDD externally via pull-up resistors so that they are pulled high when the bus is free. The I²C device address of ZXP3010GDS is shown below. The LSB bit of the 7bits device address is configured via SD0/ADDR pin.

Table I²C Address.

A7	A6	A5	A4	A3	A2	A1	W/R
1	1	0	1	1	0	SD0/ADDR	0/1

Table Electrical specification of the I²C interface pins

Parameter	Symbol	Condition	Min	Max	Unit
Clock frequency	F_{scl}			400	KHz
Time before a new transmission can start	t_{BUF}		1.3		us
Hold time for a start	t_{HDSTA}		0.6		us
Setup Time for a	t_{SUSTA}		0.6		us
Setup Time for a stop	t_{SUSTO}		0.6		us
SDA hold time	t_{HDDAT}		0.0		us
SDA setup time	t_{SUDAT}		0.1		us
SCL low pulse	t_{LOW}		1.3		us
SCL high pulse	t_{HIGH}		0.6		us

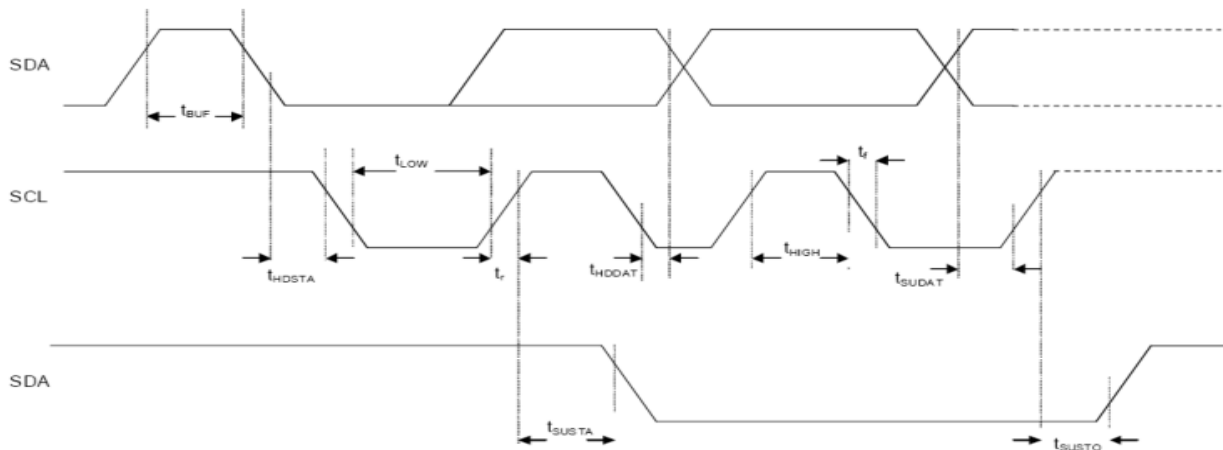

I²C Timing Diagram

The I²C interface protocol has special bus signal conditions. Start (S), stop (P) and binary data conditions are shown below. At start condition, SCL is high and SDA has a falling edge. Then the slave address is sent. After the 7 address bits, the direction control bit R/W selects the read or write operation. When a slave device recognizes that it is being addressed, it should acknowledge by pulling SDA low in the ninth SCL (ACK) cycle. At stop condition, SCL is also high, but SDA has a rising edge. Data must be held stable at SDA when SCL is high. Data can change value at SDA only when SCL is low.

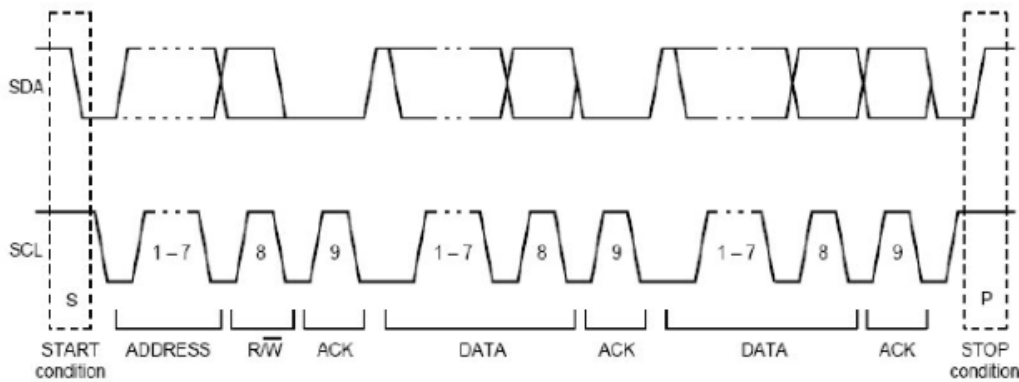

I²C Protocol

● Sensor communication

Data transfers use the I²C-bus data transfer formats to achieve the sensor register read and write protocols shown in Figure. When reading from or writing to the sensor, the master first performs a 1 byte data write to send the required register address to the sensor. The master then performs either an n byte data read or write to transfer the data, MSB first, from or to the addressed register.

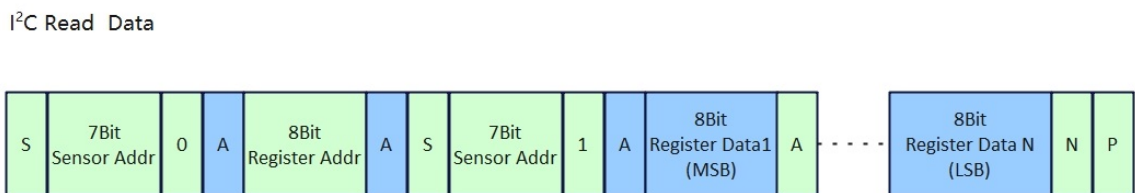
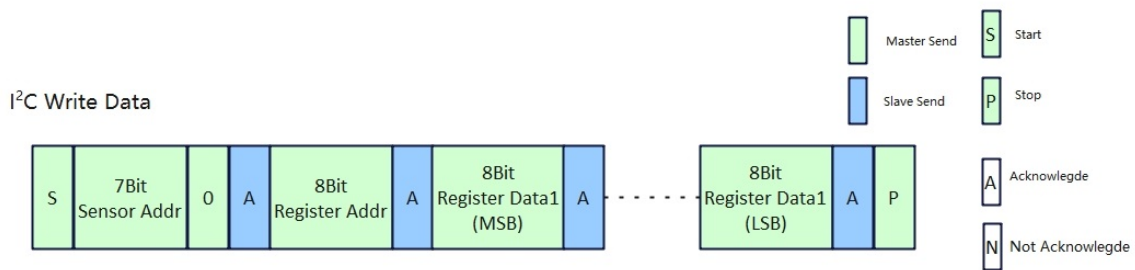

Typical I²C-bus data transfers

● Reading the pressure and temperature

The sensor directly provide compensated pressure and temperature data via the **Reg0x06-Reg0x08** and **Reg0x09-Reg0x0a** registers avoiding the need for the user

to undertake any additional calculations.

The following steps should be used to read the pressure and temperature data:

1、Read the pressure data

a. Initiate a data update.

Write 0x11 to **Reg0xA5**, output calibrated data.

Write 0x09 to **Reg0x30**, Start one time sensor signal conversion.

b. Check the status of the new data available flag.

Reg0x30 Sco: 1, Start of conversion, automatically come back to 0 after conversion ends (except sleep mode conversion).

c. Get the compensated pressure data.

Read **Reg0x06–Reg0x08**.

d. 24 bit ADC data to pressure

$P = \text{ADC data} / 2^n$, Then $2^{(23-(n+1))} < \text{FullScale} < 2^{(23-n)}$, The unit of FullScale is Pa.

2、Read the temperature data

a. Initiate a data update.

Write 0x11 to **Reg0xA5**, output calibrated data.

Write 0x08 to **Reg0x30**, Start one time temperature signal conversion.

b. Check the status of the new data available flag.

Reg0x30 Sco: 1, Start of conversion, automatically come back to 0 after conversion ends (except sleep mode conversion).

c. Get the compensated temperature data.

Read **Reg0x09–Reg0x0A**.

d. 16 bit ADC data to temperature

$T = \text{ADC data} / 256$, The unit of temperature is °C.

● Typical Applications Circuit

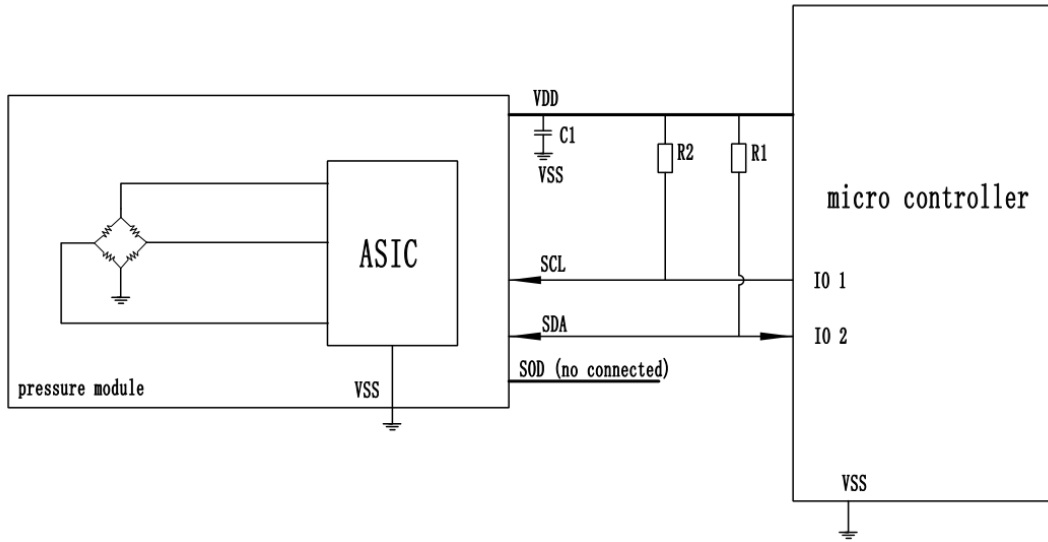

I²C Application Circuit

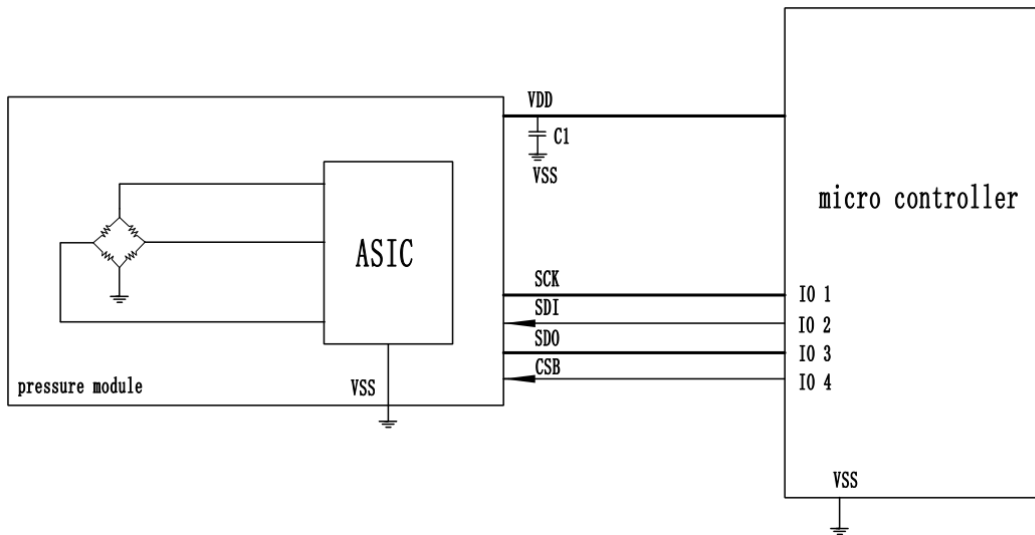

SPI Application Circuit

● **Package Dimensions**

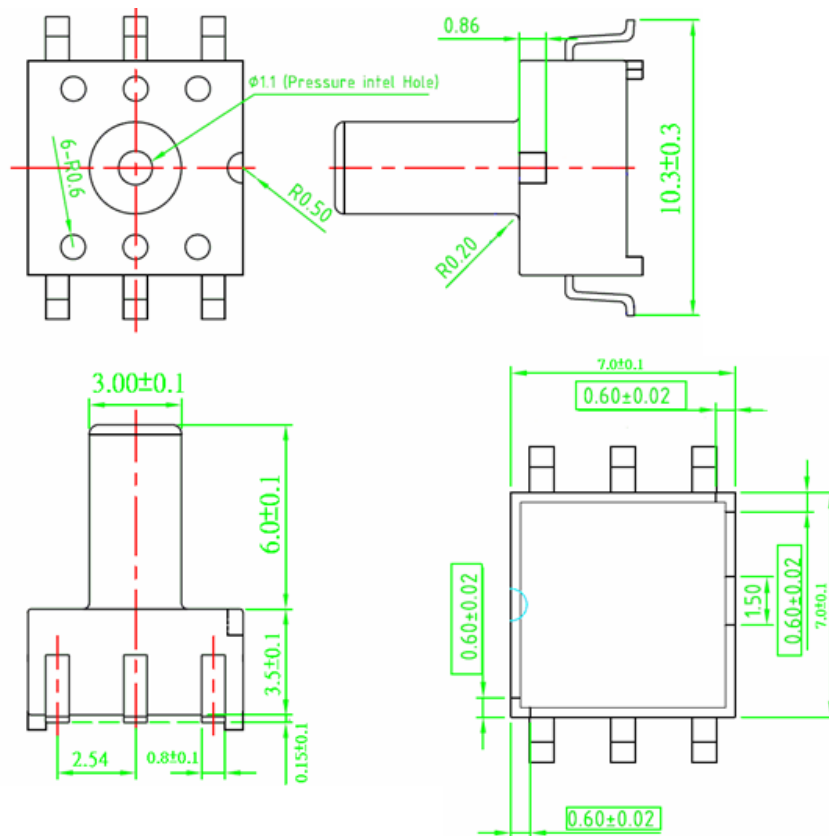

● Ordering Information

Order Code	Part Marking	Minimum Pressure Range	Positive Pressure Range	Pressure Type	Port Configuration	Shipping Method
ZXP3010GDS		0KPa	10 KPa	Gauge pressure	Single Vertical	Sticks