

BVT (2512)

ISA-WELD® PRECISION RESISTOR

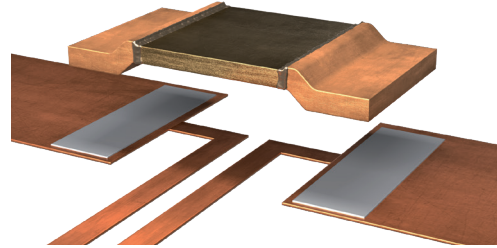

FEATURES

- Power rating up to 10 W
- Continuous current load up to 182 A (0.3 mOhm)
- Heavy copper connectors
- Excellent long-term stability
- High application temperature range -65 to +170 °C
- AEC-Q200 qualified



APPLICATIONS

- High current applications for the automotive market
- Frequency converters
- Power modules

Technical data ¹

Resistance values	mOhm	0.2 to 6.8
Tolerance	%	1 / 5
Temperature coefficient (20-60 °C)	ppm/K	from 0 ± 50
Applicable temperature range	°C	-65 to +170
Power rating P_{100 °C}	W	up to 7
Power rating P_{70 °C}	W	up to 10
Internal heat resistance (R_{thi})	K/W	from 3
Inductance	nH	<2
Stability (at rated power) deviation after 2000h	%	<0.5 ($T_{max.} = 140 \text{ °C}$) <1.0 ($T_{max.} = 170 \text{ °C}$)

¹ For detailed information see table on page 3

Ordering code

BVT - Z - R0003 - 1.0

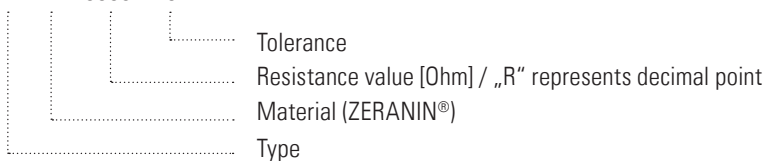

Recommended surface mount soldering methods

Reflow-, IR- and vacuum soldering

Temperature	°C	260	255	217
Time	sec	peak	40	90

Tape and reel information

Specification	DIN EN 60286-3		
Tape width	mm	12	
Reel size	inch	13	
Parts per reel	pcs	5000	
Packaging weight	g	453	

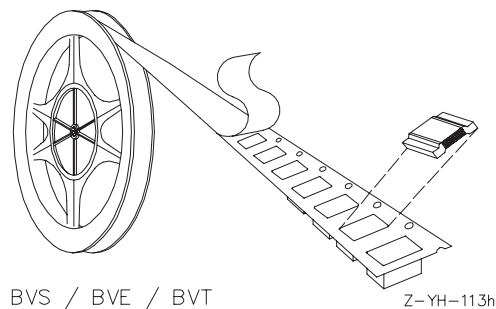

Mechanical dimensions and pcb-layout proposal (Reflow-soldering) [mm]

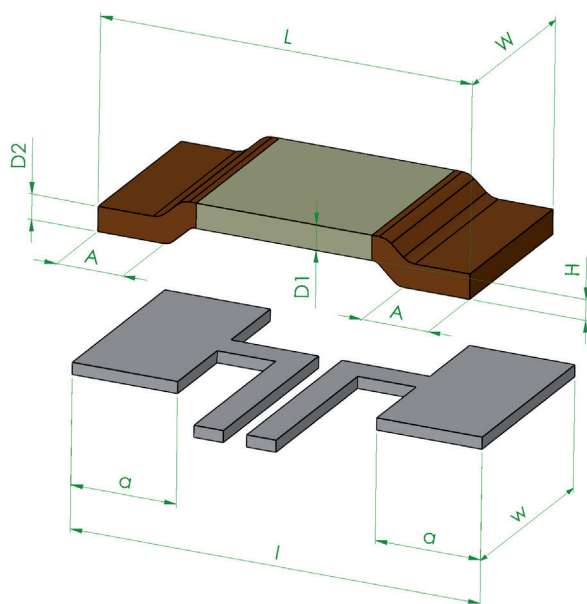

type	value / mΩ	L	W	H	A	D1	D2
BVT-K-R000					1.14 -0.4	0.42 ± 0.05	0.42 ± 0.05
BVT-Z-R0002	0.2				1.00 ± 0.4	0.92 ± 0.1	0.92 ± 0.1
BVT-Z-R0003	0.3				1.14 -0.4	1.00 ± 0.1	1.00 ± 0.1
BVT-M-R0005	0.5				1.14 -0.4	0.85 ± 0.1	0.84 ± 0.1
BVT-M-R001	1				1.14 -0.4	0.42 ± 0.05	0.42 ± 0.05
BVT-M-R00136	1.36				1.14 -0.4	0.31 ± 0.05	0.42 ± 0.05
BVT-V-R002	2				1.14 -0.4	0.46 ± 0.1	0.42 ± 0.05
BVT-I-R002	2	6.35 ± 0.15	3.05 ± 0.2	0.35 ± 0.05	1.14 -0.4	0.72 ± 0.1	0.64 ± 0.1
BVT-I-R003	3				1.14 -0.4	0.48 ± 0.05	0.42 ± 0.05
BVT-A-R003	3				1.14 -0.4	0.48 ± 0.05	0.42 ± 0.05
BVT-I-R004	4				1.14 -0.4	0.36 ± 0.05	0.42 ± 0.05
BVT-I-R0045	4.5				1.14 -0.4	0.36 ± 0.05	0.42 ± 0.05
BVT-I-R005	5				1.14 -0.4	0.36 ± 0.05	0.42 ± 0.05
BVT-I-R0068	6.8				1.14 -0.4	0.36 ± 0.05	0.42 ± 0.05

Solder pad type	l	w	a
BVT	7	3.4	1.8
BVT-Z-R0002	7	3.4	2.2

Electrical specification

Type	Material	Value [mΩ]	R_{thi} [K/W]	TCR [ppm/K]	$P_{70^{\circ}C^*}$ [W]	$P_{100^{\circ}C^*}$ [W]
BVT-K-R000	Copper	0			$I_{max} = 100$ A	
BVT-Z-R0002	ZERANIN®30	0.2	3	350 ± 50	10	10
BVT-Z-R0003	ZERANIN®30	0.3	4	150 ± 50	10	10
BVT-M-R0005	MANGANIN®	0.5	7	70 ± 50	10	6
BVT-M-R001	MANGANIN®	1.0	14	50 ± 50	7	5
BVT-M-R00136	MANGANIN®	1.36	16	30 ± 50	6	4.5
BVT-V-R002	NOVENTIN®	2.0	20	0 ± 50	5	3.5
BVT-I-R002	ISAOHM®	2.0	16	0 ± 50	6	4.5
BVT-I-R003	ISAOHM®	3.0	24	0 ± 50	4	3
BVT-I-R004	ISAOHM®	4.0	32	0 ± 50	3	2
BVT-I-R0045	ISAOHM®	4.5	36	0 ± 50	2.5	2
BVT-I-R005	ISAOHM®	5.0	40	0 ± 50	2.5	1.5
BVT-I-R0068	ISAOHM®	6.8	60	0 ± 50	1.5	1

* Recommended max. power (limited by thermal conditions of the assembly)

Note: For calculation of the maximum derating terminal temperature (T_K) the following formula can be used: $T_K = T_{max} - (R_{thi} \times P)$.
 Example for BVT-Z-R0003: $T_K = 170^{\circ}C - (4 \text{ K/W} \times 10 \text{ W}) = 130^{\circ}C$.

Temperature dependence of the electrical resistance of ZERANIN® resistors. Example: BVT-Z-R0003

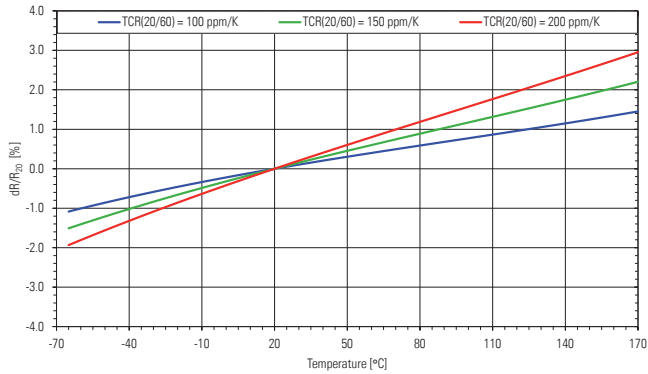

Temperature dependence of the electrical resistance of ISAOHM® resistors. Example: BVT-I-R002

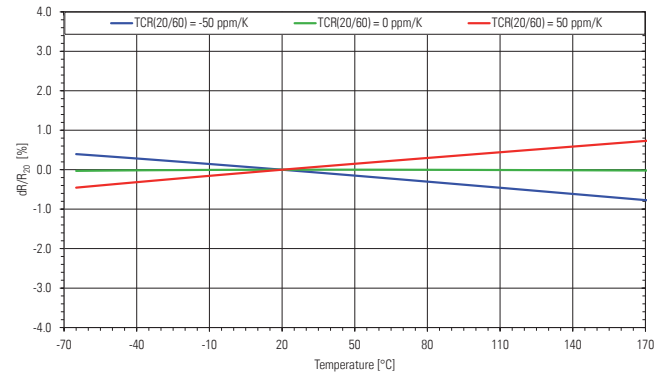

Temperature dependence of the electrical resistance of NOVENTIN® resistors. Example: BVT-V-R002

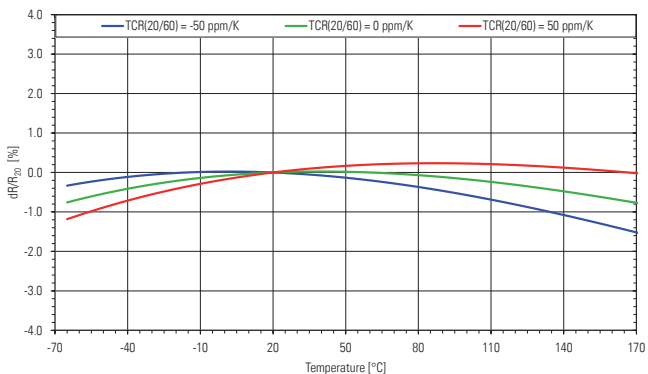

Temperature dependence of the electrical resistance of MANGANIN® resistors. Example: BVT-M-R0005

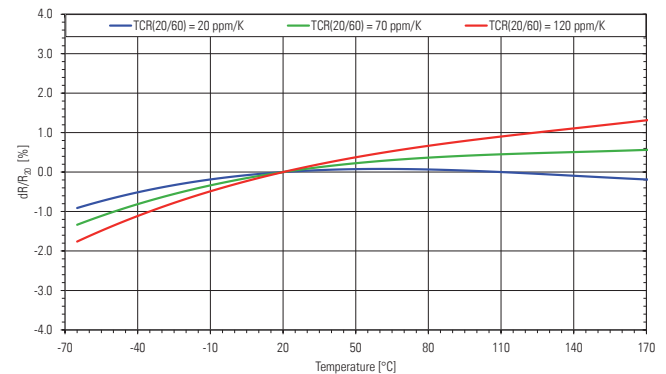

Power derating curve at 70°C. (see table on page 3)

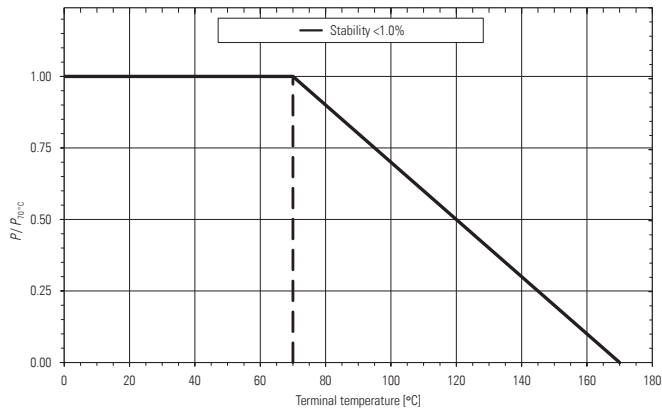

**Power derating curve BVT-M-R001/R00136/
V-R002/I-R002/I-R003/I-R0045**

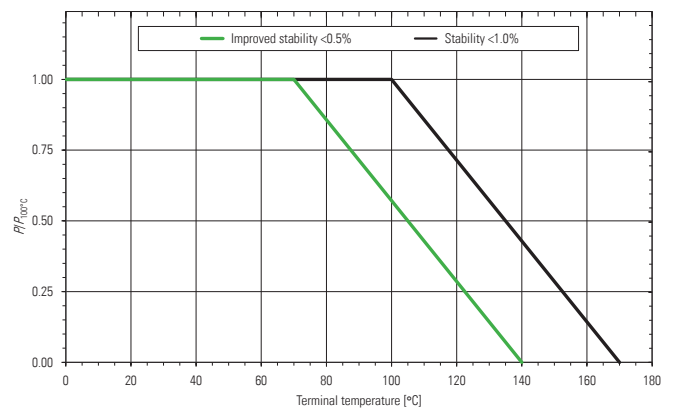

Power derating curve BVT-Z-R0002

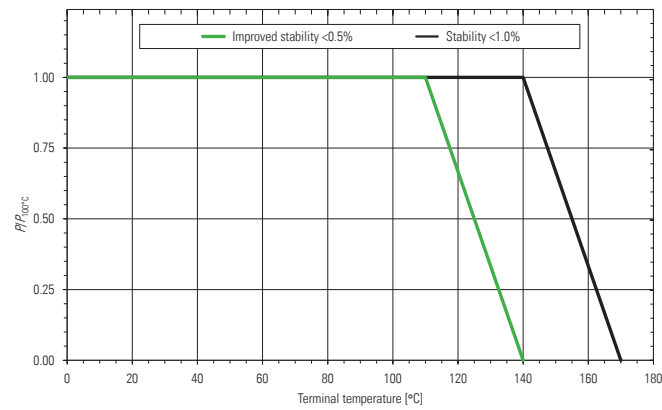

Power derating curve BVT-Z-R0003/M-R0005

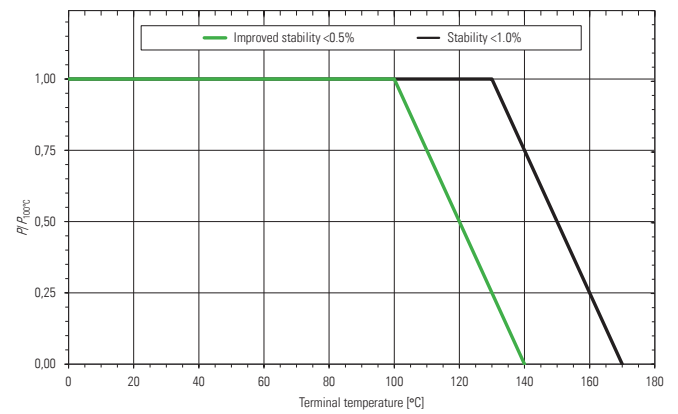

Power derating curve BVT-I-R004/R005/R0068

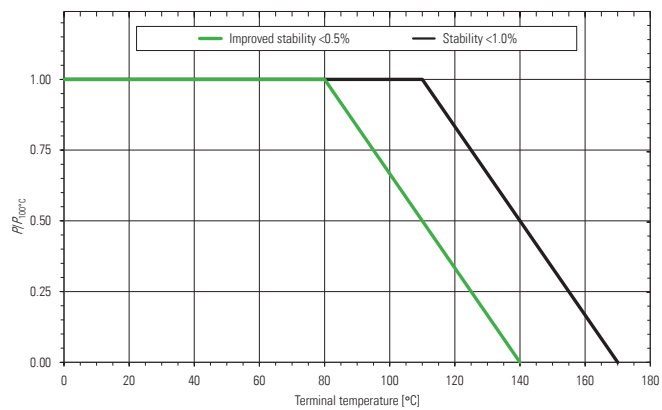

Maximum pulse energy respectively pulse power for permanent operation

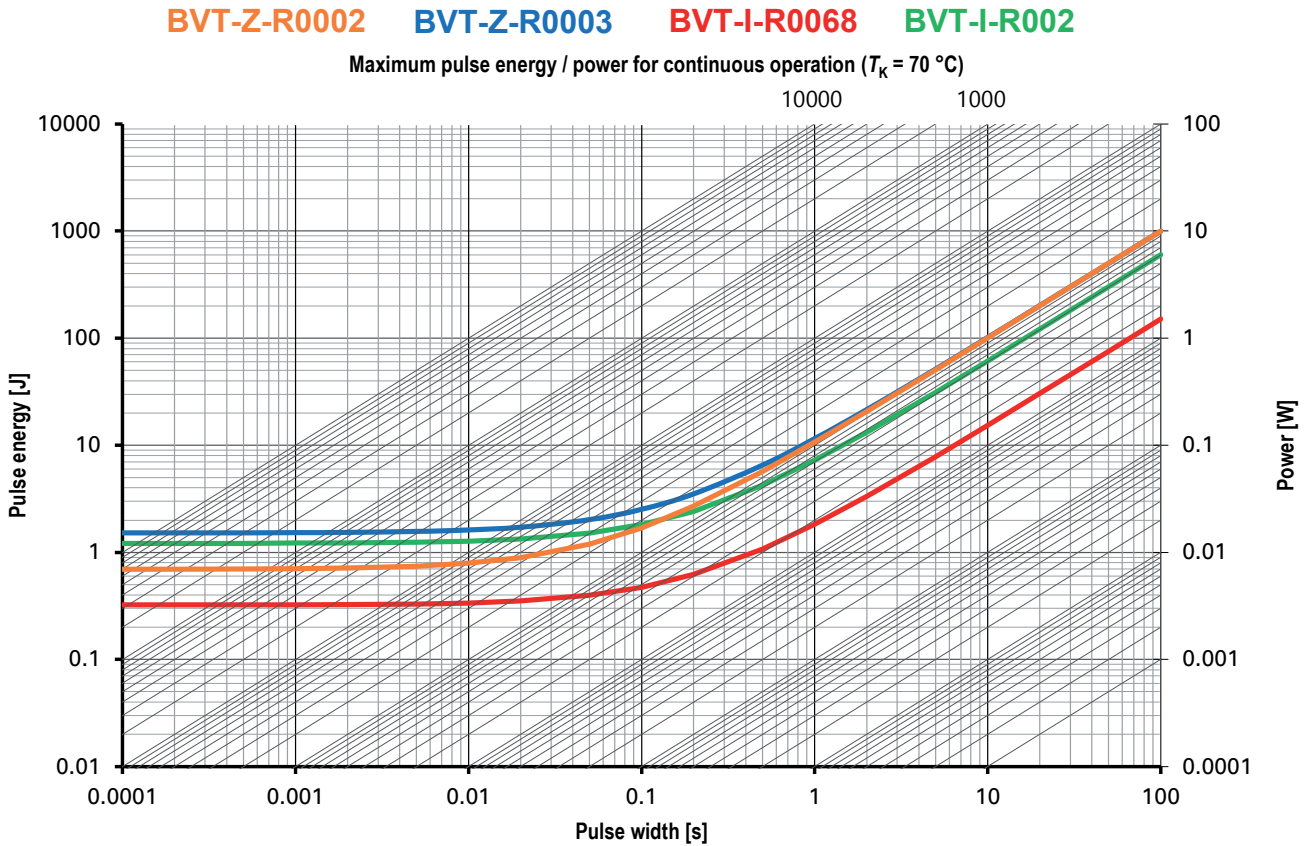

Test specification

Parameters	Test conditions	Specified values
Temperature Cycling	2000 cycles (-55 °C to +150 °C)	±0.5 %
Low Temperature Storage and Operation	-65 °C for 250 h	±0.1 %
Mechanical Shock	100 g, 6 ms half sine	±0.2 %
Vibration, High Frequency	10 g, 10-2000 Hz, 24 h each axis	±0.2 %
Operational Life	2000 h, max. T_K at rated power	±1.0 %
High Temperature Exposure	2000 h / 170 °C (in covered condition)*	±1.0 %
Bias Humidity	+85 °C, 85 r.F., 1000 h	±0.5 %

* for MANGANIN® and ZERANIN®30

Disclaimer // All products, product specifications and data are subject to change without notice. The product specifications do not expand or otherwise modify Isabellenhütte's terms and conditions of sale, including but not limited to, the warranty expressed therein. Isabellenhütte makes no warranty, representation or guarantee other than as set forth in its terms and conditions of sale. Information provided in datasheets and/or specifications may vary from actual results in different applications. Any statements made by Isabellenhütte regarding the suitability of products for certain types of applications are based on its knowledge of typical requirements that are often placed on its products. It is the customer's responsibility to validate that a particular product with the properties described in the product specification is suitable for use in the application intended. No license, express or implied, or otherwise, to any intellectual property rights is granted by this document. Any and all liability arising out of the application or use of any product shall be as set forth in Isabellenhütte's terms and conditions of sale.

