

Data Sheet

Customer: _____

Product: Wire Wound Chip Inductor – SCI High Current Series

Size : 1008/1210/1812

Issued Date: 26-Jul.-2016

Edition: Ver. 3

Record of change

Date	Ver.	Description	Page
30-Sep.-2014	1		
28-Aug-2015	2	Add size 1008	4
26-Jul.-2016	3	Revised operating & storage temperature range	3
09-Oct.-2019	4	Update size 1812	4-5

HITANO ENTERPRISE CORP.

7F-7, No. 3, Wu Chuan 1st Road, New Taipei Industrial Park,

New Taipei City, TAIWAN, R.O.C.

Tel: +886 2 2299 1331 (Rep.)

Fax: +886 2 2298 2466, 2298 2969

Prepared by	Checked by	Approved by	Accepted by (customer)
30-Sep.-2014	30-Sep.-2014	30-Sep.-2014	
<i>Andy Hsu</i>	<i>Hwa Wu</i>	<i>Hwa Wu</i>	

WIRE WOUND CHIP INDUCTOR

SCI (H)SERIES

■ Introductions

The SCI (H) series are chip inductors with large current widely used in the communication applications and the other electronic devices, such as cellular phones, Television, Video Camera, Radio, Smart Meters and the other devices.

■ Features

- * Excellent solder ability and resistance to soldering heat.
- * With metal terminals and resin coated, it offers many superior features, such as highly resistant to mechanical shocks and pressure, reliable in environments of sudden temperature change and humidity and super Q characteristics.
- * Highly accurate dimensions, high reliability, and easy surface mount assembly.
- * Large current capability can be used for applications that need to meet high DC rated current.

■ Chip Dimension

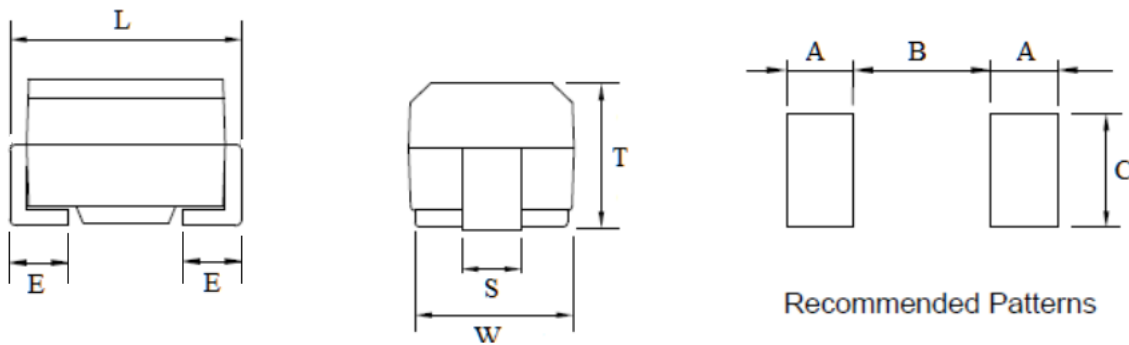

Size	L	W	T	S	E	A	B	C	Unit (mm)
SCI1008(H)	2.50±0.20	2.00±0.0	2.20±0.20	1.80±0.10	0.40	1.0	1.5	1.0	
SCI1210(H)	3.20±0.20	2.50±0.20	2.20±0.20	1.90±0.10	0.55	1.20	2.0	2.0	
SCI1812(H)	4.50±0.30	3.20±0.20	3.20±0.20	1.20	1.0 +0.3 -0.0	1.50	2.2	1.60	

■ Part Numbering

SCI	1210	H	T	1R0	J	□□
SERIES	SIZE	MATERIAL	PACKAGE	INDUCTANCE	TOLERANCE	INTERNAL CODE
Wire Wound	1008	H =High Current	T= Tape&Reel	R10= 0.1uH	K= ±10%	
Molded	1210			1R0= 1.0uH	M=±20%	
	1812			330= 33uH		
				331= 330 uH		

WIRE WOUND CHIP INDUCTOR

SCI (H)SERIES

■ Construction & Dimension

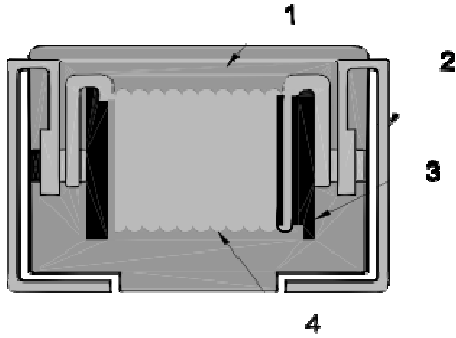

1	Molded resin	3	Ferrite Core
2	Electrode(Ag)	4	Magnet Wire

■ Operating Temperature Range:

Operating Temperature Range is the scope of ambient temperature at which the inductors can be operated continuously at rated current includes self-temperature rise.

- * SCI1008(H) Type: -40 to +105°C
- * SCI1210(H) Type: -40 to +105°C
- * SCI1812(H) Type: -25 to +85°C

■ Storage Temperature Range:

Storage Temperature Range is the scope of ambient temperature at which the inductors are mounted on the circuit board already.

- * SCI1008(H) Type: -40 to +85°C
- * SCI1210(H) Type: -40 to +85°C
- * SCI1812(H) Type: -25 to +85°C

■ Characteristics:

Standard Test Condition:

Unless otherwise specified, the standard range of atmospheric conditions for making measurements and tests are as follows:

- * Ambient Temperature: 25°C ± 2°C
- * Relative Humidity : 60% to 70%
- * AirPressure : 86 Kpa to 106 Kpa

WIRE WOUND CHIP INDUCTOR

SCI (H)SERIES

■ Electrical Specification

Size 1008 High Current Type

Part No.	Inductance	Q	Test Freq.	Tol.	RDC(max)	IDC(max)
	(μ H)	(min)	(MHz)	(%)	(Ω)	(mA)
SCI 1008 HT 1R0 □-□□	1	20	7.96	M	0.34	475
SCI 1008 HT 1R5 □-□□	1.5	20	7.96	M	0.42	435
SCI 1008 HT 2R2 □-□□	2.2	20	7.96	M	0.50	390
SCI 1008 HT 3R3 □-□□	3.3	20	7.96	M	0.65	340
SCI 1008 HT 4R7 □-□□	4.7	20	7.96	M	0.80	285
SCI 1008 HT 6R8 □-□□	6.8	30	7.96	M	1.00	275
SCI 1008 HT 100 □-□□	10	30	2.52	K	1.69	210
SCI 1008 HT 150 □-□□	15	30	2.52	K	2.20	175
SCI 1008 HT 220 □-□□	22	30	2.52	K	2.80	160
SCI 1008 HT 330 □-□□	33	30	2.52	K	4.20	120

- * Tolerance: K=±10%, M=±20%
- * Operating Temperature: -40°C to +105°C
- * Inductance & Q value measured in HP4191A
- * SRF measured in 8753 Agilent
- * DC Resistance RDC measured in VP-2941A Panasonic
- * Unspecified values available on request.

WIRE WOUND CHIP INDUCTOR

SCI (H)SERIES

Size 1210 High Current Type

Part No.	Inductance	Q	Test Freq.	Tol.	S.R.F.(min)	RDC(max)	IDC(max)
	(uH)	(min)	(MHz)	(%)	(MHz)	(Ω)	(mA)
SCI 1210 HT 1R0 □-□□	1	10	7.96	M	100	0.06	1000
SCI 1210 HT 1R5 □-□□	1.5	10	7.96	M	80	0.11	830
SCI 1210 HT 2R2 □-□□	2.2	10	7.96	M	68	0.13	770
SCI 1210 HT 3R3 □-□□	3.3	10	7.96	M	54	0.16	690
SCI 1210 HT 4R7 □-□□	4.7	10	7.96	M	46	0.20	620
SCI 1210 HT 6R8 □-□□	6.8	10	7.96	M	38	0.27	530
SCI 1210 HT 100 □-□□	10	15	2.52	K	30	0.36	450
SCI 1210 HT 150 □-□□	15	15	2.52	K	26	0.56	370
SCI 1210 HT 220 □-□□	22	15	2.52	K	21	0.77	300
SCI 1210 HT 330 □-□□	33	15	2.52	K	17	1.10	240
SCI 1210 HT 470 □-□□	47	15	2.52	K	14	1.64	180
SCI 1210 HT 680 □-□□	68	20	2.52	K	12	2.80	140
SCI 1210 HT 101 □-□□	100	20	2.52	K	10	3.70	120
SCI 1210 HT 151 □-□□	150		0.796	K	8	6.10	100
SCI 1210 HT 221 □-□□	220		0.796	K	7	8.40	80
SCI 1210 HT 331 □-□□	330		0.796	K	6	12.3	70

- * Tolerance: Tolerance: K=±10%, M=±20%
- * Operating Temperature: -40°C to +105°C
- * Inductance & Q value measured in HP4191A
- * SRF measured in 8753 Agilent
- * DC Resistance RDC measured in VP-2941A Panasonic
- * Unspecified values available on request.

WIRE WOUND CHIP INDUCTOR

SCI (H)SERIES

Size 1812 High Current Type

Part No.	Inductance	Q	Test Freq.	Tol.	S.R.F.(min)	RDC(max)	IDC(max)
	(uH)	(min)	(MHz)	(%)	(MHz)	(Ω)	(mA)
SCI 1812 HT 1R0 □-□□	1.0	10	7.960	J, K, M	265.0	0.11	1050
SCI 1812 HT 1R2 □-□□	1.2	10	7.960	J, K, M	180.0	0.12	1000
SCI 1812 HT 1R5 □-□□	1.5	10	7.960	J, K, M	170.0	0.15	950
SCI 1812 HT 1R8 □-□□	1.8	10	7.960	J, K, M	105.0	0.16	900
SCI 1812 HT 2R2 □-□□	2.2	10	7.960	J, K, M	80.0	0.18	850
SCI 1812 HT 2R7 □-□□	2.7	10	7.960	J, K, M	60.0	0.20	800
SCI 1812 HT 3R3 □-□□	3.3	10	7.960	J, K, M	55.0	0.22	750
SCI 1812 HT 3R9 □-□□	3.9	10	7.960	J, K, M	45.0	0.24	700
SCI 1812 HT 4R7 □-□□	4.7	10	7.960	J, K, M	43.0	0.27	650
SCI 1812 HT 5R6 □-□□	5.6	10	7.960	J, K, M	40.0	0.30	650
SCI 1812 HT 6R8 □-□□	6.8	10	7.960	J, K, M	35.0	0.35	600
SCI 1812 HT 8R2 □-□□	8.2	10	7.960	J, K, M	30.0	0.40	600
SCI 1812 HT 100 □-□□	10	10	2.520	J, K, M	27.0	0.50	550
SCI 1812 HT 120 □-□□	12	10	2.520	J, K, M	25.0	0.60	500
SCI 1812 HT 150 □-□□	15	10	2.520	J, K, M	20.0	0.70	450
SCI 1812 HT 180 □-□□	18	10	2.520	J, K, M	19.0	0.80	400
SCI 1812 HT 220 □-□□	22	10	2.520	J, K, M	18.0	0.90	370
SCI 1812 HT 270 □-□□	27	10	2.520	J, K, M	16.0	1.20	330
SCI 1812 HT 330 □-□□	33	10	2.520	J, K, M	15.0	1.40	300
SCI 1812 HT 390 □-□□	39	10	2.520	J, K, M	13.0	1.60	280
SCI 1812 HT 470 □-□□	47	10	2.520	J, K, M	12.0	1.90	260
SCI 1812 HT 560 □-□□	56	10	2.520	J, K, M	10.0	2.20	240
SCI 1812 HT 680 □-□□	68	10	2.520	J, K, M	9.5	2.60	220
SCI 1812 HT 820 □-□□	82	10	2.520	J, K, M	8.5	3.50	200
SCI 1812 HT 101 □-□□	100	20	0.796	J, K, M	8.0	4.00	180
SCI 1812 HT 121 □-□□	120	20	0.796	J, K, M	7.0	4.50	160
SCI 1812 HT 151 □-□□	150	20	0.796	J, K, M	6.5	6.50	140
SCI 1812 HT 181 □-□□	180	20	0.796	J, K, M	6.0	7.50	120
SCI 1812 HT 221 □-□□	220	20	0.796	J, K, M	5.5	9.00	120
SCI 1812 HT 271 □-□□	270	20	0.796	J, K, M	5.0	11.00	100
SCI 1812 HT 331 □-□□	330	20	0.796	J, K, M	4.5	13.00	90
SCI 1812 HT 391 □-□□	390	20	0.796	J, K, M	4.0	14.00	85
SCI 1812 HT 471 □-□□	470	20	0.796	J, K, M	3.5	16.00	75
SCI 1812 HT 561 □-□□	560	20	0.796	J, K, M	3.0	21.00	70
SCI 1812 HT 681 □-□□	680	20	0.796	J, K, M	2.5	24.20	65

- * Tolerance: K=±10%, M=±20%
- * Operating Temperature: -25°C to +85°C
- * Inductance & Q value measured in HP4291 or HP4284
- * SRF measured in HP4291
- * DC Resistance RDC measured in Agilent 34401A
- * Unspecified values available on request.

■ **Soldering Profile**

Reflow Soldering

Typical RoHS Reflow Profile

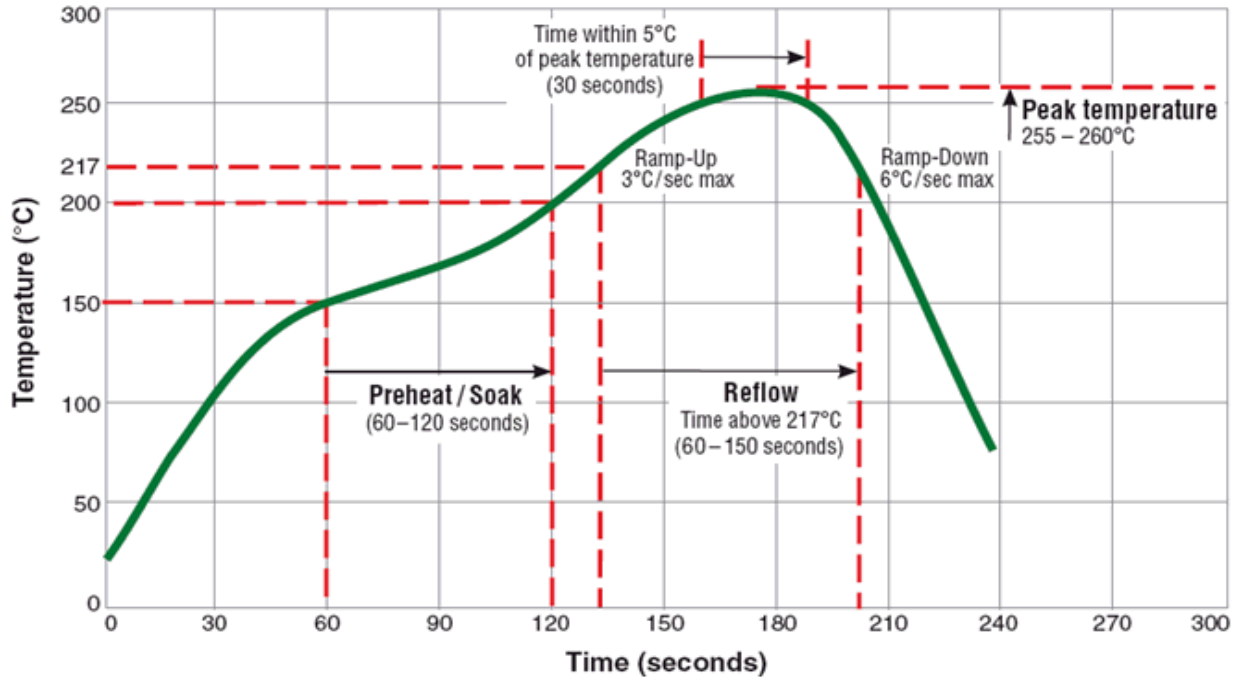

Manual Soldering

Soldering iron tip temperature: 350°C max / within 3 seconds.

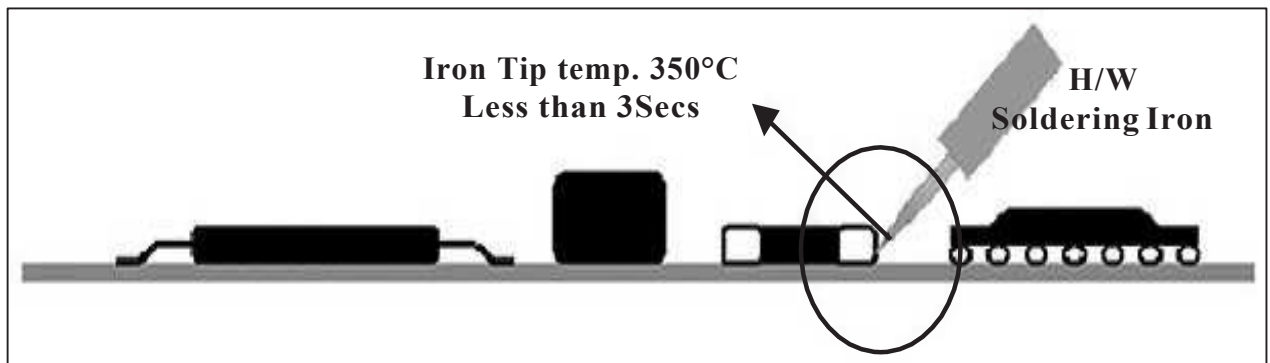

WIRE WOUND CHIP INDUCTOR

SCI (H)SERIES

■ Specification & Test Method

	ITEM	CONDITION	SPECIFICATION															
Mechanical Performance Test	Solderability	The electrodes shall be at least 90% covered with new solder coating	Lead-free inductor: after fluxing(alpha 100 or equiv), inductor shall be dipped in a melted solder bath at 245±5°C, 5±0.5 seconds															
	Resistance to Soldering Heat	Appearance: No damage	Pre-heating: 150°C, 1min. Solder Temperature: 260±5°C Immersion Time: 10±1 seconds															
	Vibration	Appearance: No damage L change: within±10% Q change: within±30% DCR: within specification	Test device shall be soldered on the substrate Oscillation Frequency: 10 to 55 to 10Hz for 1 min. Amplitude: 1.5 mm Time: 2 hrs for each axis (X, Y&Z), total 6 hrs															
Electrical Performance Test	Inductance	Refer to standard electrical characteristic spec	HP4291 or HP4284															
	Q		HP4291 or HP4284															
	SRF		HP4291															
	DC Resistance DCR		Agilent 34401A															
	Rated Current IDC		Applied the current to coils, The inductance change should be less than 10% to initial value															
Climatic Performance Test	Temperature Cycle	Appearance: No damage L change: within±10% Q change: within±30% DCR: within specification	One cycle: <table border="1"> <thead> <tr> <th>Step</th> <th>Temperature (°C)</th> <th>Time (min.)</th> </tr> </thead> <tbody> <tr> <td>1</td> <td>-25±3</td> <td>30</td> </tr> <tr> <td>2</td> <td>25±2</td> <td>3</td> </tr> <tr> <td>3</td> <td>85±3</td> <td>30</td> </tr> <tr> <td>4</td> <td>25±2</td> <td>3</td> </tr> </tbody> </table> Total: 100 cycles Measured after exposure in the room condition for 24 hrs	Step	Temperature (°C)	Time (min.)	1	-25±3	30	2	25±2	3	3	85±3	30	4	25±2	3
	Step		Temperature (°C)	Time (min.)														
	1		-25±3	30														
	2		25±2	3														
3	85±3	30																
4	25±2	3																
Damp Heat with Load	Temperature: 40±2°C Relative Humidity: 90 ~ 95% Time: 1000 hrs Measured after exposure in the room condition for 24 hrs																	
High Temperature Storage	Temperature: 85±3°C Applied Current: Rated Current Time: 1000 hrs Measured after exposure in the room condition for 24 hrs																	
Low Temperature Storage	Temperature: -25±3°C Time: 1000 hrs Measured after exposure in the room condition for 24 hrs																	

WIRE WOUND CHIP INDUCTOR

SCI (H)SERIES

■ Packaging

Packaging Quantity & Reel Specifications

Type	ΦA	ΦB	ΦC	W	T	Q'ty
SCI1008(H)	178±2.0	60±0.5	13±0.3	9±0.3	12±1.0	2000
SCI1210(H)	178±2.0	60±0.5	13±0.3	9±0.3	12±1.0	2000
SCI1812(H)	178±2.0	80±0.5	13±0.3	13.2±0.3	16±1.0	500

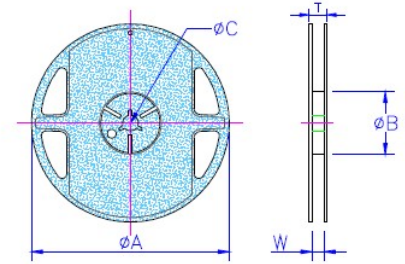

Embossed Plastic Tape Specifications

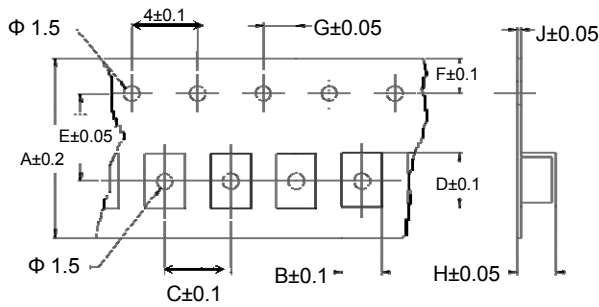

Unit: mm

Type	A	B	C	D	E	F	G	H	J
SCI1008(H)	8	2.70	4	3.60	3.5	1.75	2	2.40	0.23
SCI1210(H)	8	2.96	4	3.60	3.5	1.75	2	2.40	0.23
SCI1812(H)	12	3.30	8	5.00	5.5	1.75	2	3.50	0.30

Leader / Trailer Tape

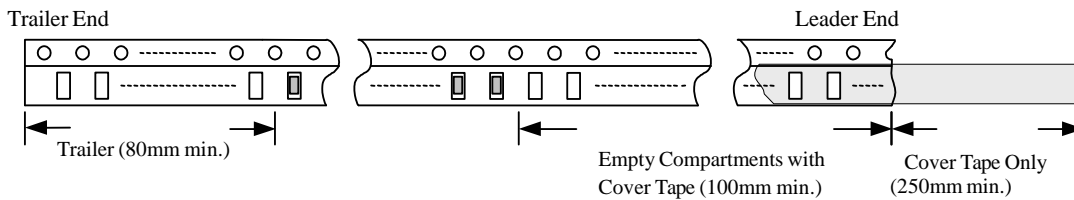

Cover Tape Peel Strength

The force for tearing off cover tape is 0.1~0.6 (N) in the arrow direction at the following conditions: Temperature: 5~35°C

Humidity: 45~85%

Atmospheric Pressure: 860~1060 hpa

