

SPECIFICATION

Product : **Programable LED Driver**

Model Name : **CVT230 – xxxx...xxx**

(xxxx...xxx : target LCD part number)

Supportable Dimming : **External PWM and Analog**

April 2019

Revision History

Rev.	Date	Revision Details	Remarks
A	Oct 16, 2018	Engineering Sample Issue	
B	Mar 18, 2019	Initial version start (the first product model)	
C	Apr 01, 2019	The second Production start	
	Apr 30, 2019	The addition of MTBF data	

1. DESIGN CONCEPT OF PRODUCT

This product has been designed for providing an easiest way of suitable LED driver adoption based on a fixed hardware model which can be applicable for various TFT LCD Modules.

In order to overcome the difficulty from too many different hardware supply in every time when all users need to drive a target LCD panel, this product allow to settle the key parameters of LCD backlight LED rail through a program which can settle below parameters ;

- the number of LED Channel,
- the level of current on each LED string a
- the adoptable Voltage level as the OVP (Over Voltage Protection).

This model has max 6 channel supportable and 1000mA level current supportable,
Further details about users' manual will guide how to use this product, refer to the attached Appendix.

2. BLOCK DIAGRAM

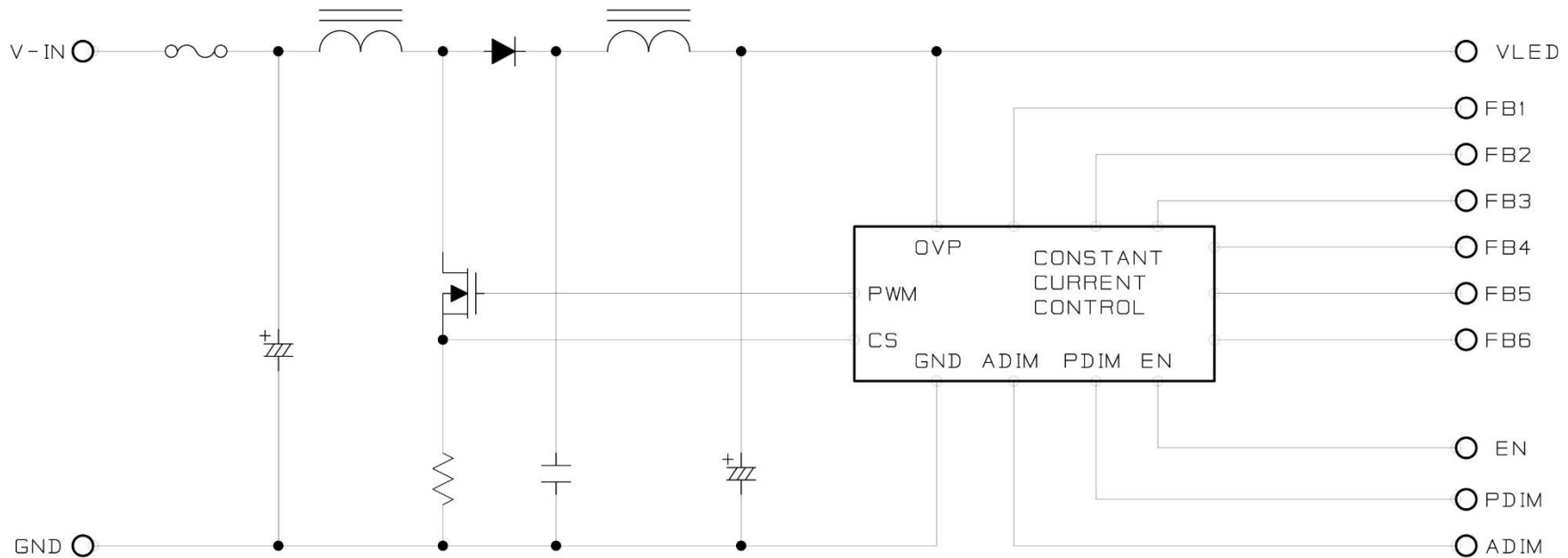

3. ELECTRICAL PARAMETERS

3.1 Input Requirements

Parameter		Symbol	Values			Unit	Remark	
			Min	Typ	Max			
Power Supply Input Voltage		VBL	10.8	12	18	Vdc	** 1	
		VBL	18	24	29	Vdc		
Power Supply Input Current		IBL	-	-	3	A	VBL = 12V Ext VBR-B =100%	
		IBL	-	-	1.8	A	VBL = 24V Ext VBR-B =100%	
Power Supply Input Current (In-rush)		In-rush	-	-	6	A	VBL = 10.8V Ext VBR-B =100%	
Power Consumption		PBL	-	-	32	W		
Input Voltage for Control System Signals	On/Off	On	V on	2.4	-	5.25	Vdc	On Duty ** 2 HIGH : On duty LOW : Off duty ** 2
		Off	V off	-0.3	-	0.8	Vdc	
	Brightness Adjust		ExtVBR-B	3	-	100	%	
	Pulse Duty Level (PWM)		High Level	2.4	-	5.25	Vdc	
			Low Level	0.0	-	0.7	Vdc	
			PWM Freq.	100		240	Hz	
			Duty	2	-	100	%	
Analog Dimming		A-DIM	0	-	3	V	0V : Min Bright 3V :Max Bright	

** 1) The LED string voltage always has to be higher than the input voltage (max) and the difference must be at least 5V deviation.

** 2) To use PWM duty less than 10%, the frequency of dimming should be 120Hz or less

3.2 Output Requirements
 3.2.1 Maximum Output Voltage and Current

Voltage	Constant Current Range	Channel	Maximum Wattage	Output Constant Current per channel (mA)			Total Output Constant Current (mA)		
				Min.	Typ.	Max.	Min.	Typ.	Max.
OUTPUT	15V ~ 60V	1Ch ~ 6Ch	32W under	50	-	1000	50	-	1000

- The voltage and current per LD Backlight string are set according to the LCD demand

3.2.2 Ripple and Noise

The ripple and noise are defined as a periodic or random signal over frequency band at the 10Hz ~ 20MHz, measuring by an oscilloscope capable 20MHz bandwidth.

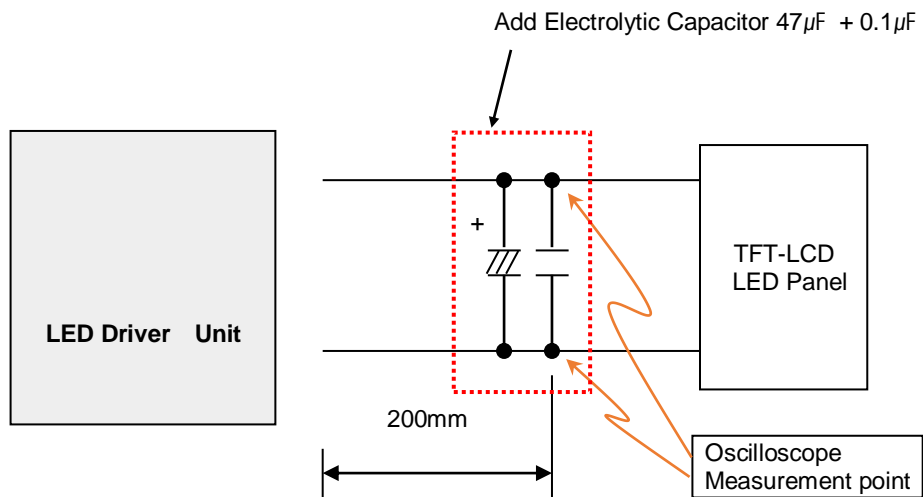

Output Voltage	LED Output
Ripple Voltage Range (mV)	5000

※ The ripple & noise are measured at the 20MHz bandwidth by a 12" twisted pair-wire which is cut off through the 0.1 μ F & 47 μ F parallel capacitor.

☞ Test condition

- Temperature: 25°C room temperature
- Test equipment: PWM Dimming 100%

3.2.3 Overshoot

The output overshoot at the boot up must not exceed 25% than ordinary operating voltage value whether it is under a loading condition or not.

3.2.4 Output Rise Time

At the moment of turning on, the rise time of output voltage has to be shorter than 200msec, which is measured from the 10% point to the 90% point at the optimal level

☞ Test condition

- Temperature: 25°C room temperature
- Test equipment: Resistance load

3.3 Power Output Protection

3.3.1 Over Voltage Protection (OVP)

The voltage will not exceed the upper trip limit.

The noise spikes (exceeding the trip limit smaller than 10 μ s) will not restrict the output voltage at zero level.

3.3.2 Specification of Protection

Voltage	Over Voltage Protection	
	Range[V]	Protection
OUTPUT	Set 10V higher than the string voltage of panels.	Shut Down

4. Absolute Raring

4.1 Temperature

- Operating Temp. : -35 ~ 85°C (optional guarantee – up to -40°C)
- Storage Temp. : -35 ~ 85°C (optional guarantee – up to -40°C)

4.2 Humidity

- Operation humidity : 20 ~ 85% non-condensate
- Storage humidity : 5 ~ 95% non-condensate

5. Pin Information

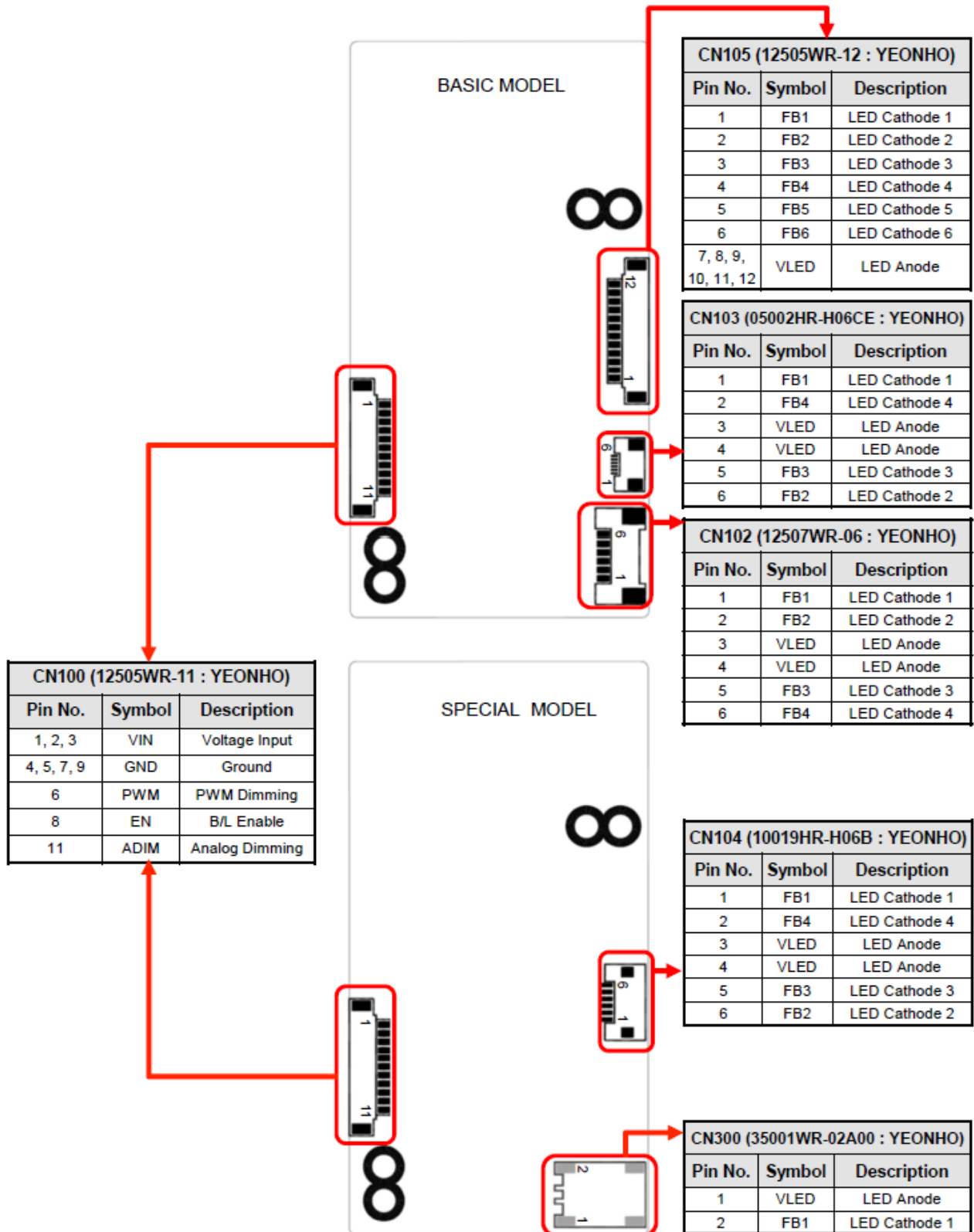

6. Dimension (83 x 43 mm x 11mm) and Pictures

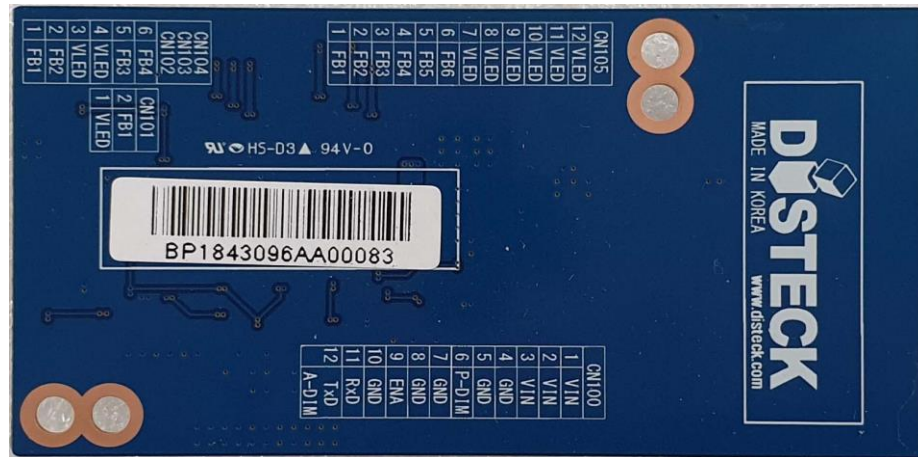
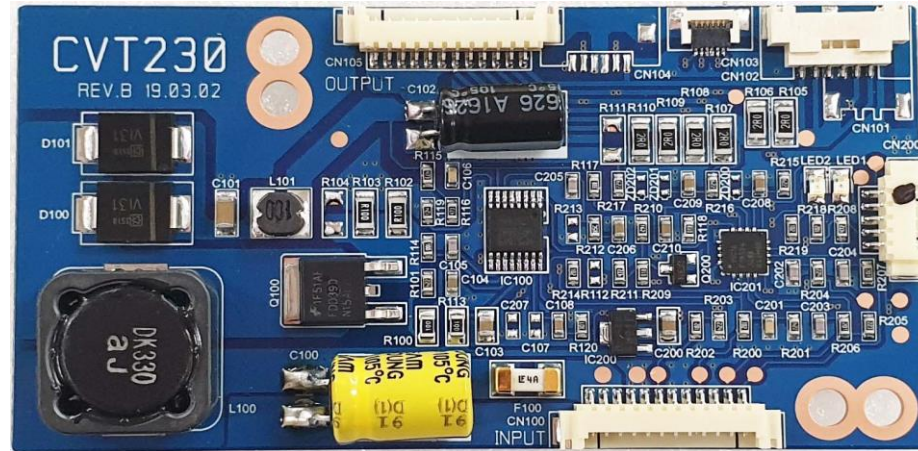
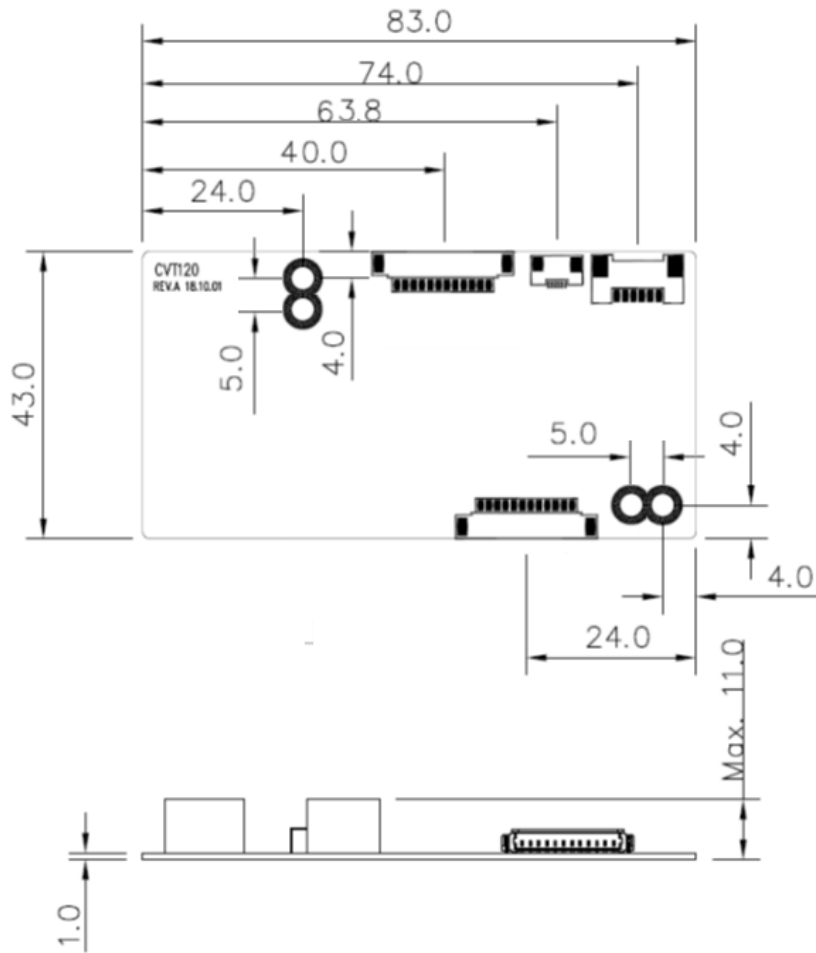

7. RELIABILITY TEST

7.1 Environment Test

Adopted Test	Test method																		
Intermittent Operating Stability Test	The electrical characteristics have to be passed this test under the none stop power "On" and "Off" during the 25,000 hours by the in every 10 seconds interval on the maximum load condition																		
Low Temp. Operating Test	The test has to be done for 200 hours under – 30 degree Celsius condition and the product has to meet the normal operation without any trouble for electrical characteristics																		
High Temp. & High Humidity Operating Test	The test has to be done for 200 hours under +85 degree Celsius and 85% relevant Humidity condition and the product has to meet the normal operation without any trouble for electrical characteristics																		
Low Temp. Storage Test	The test has to be done for 96 hours or more under – 35 degree Celsius condition. Then the switching regulator is left at the ambient temperature and humidity for 1 hour or more, consequently the product has to meet the normal operation without any trouble for electrical characteristics																		
Heat cycle Operating Test	<p>The test has to be done under 10 times cycling condition like below under ambient temperature and humidity for 1 hour or more. Then consequently the product has to meet the normal operation without any trouble for electrical characteristics.</p> <table border="1"> <thead> <tr> <th>Consecutive Cycle</th> <th>Temperature</th> </tr> </thead> <tbody> <tr> <td>10 minutes</td> <td>25°C</td> </tr> <tr> <td>30 minutes</td> <td>25°C → -35°C</td> </tr> <tr> <td>240 minutes</td> <td>Minimum temperature(-35°C)</td> </tr> <tr> <td>30 minutes</td> <td>-35°C → 25°C</td> </tr> <tr> <td>10 minutes</td> <td>25°C</td> </tr> <tr> <td>30 minutes</td> <td>25°C → 85°C</td> </tr> <tr> <td>240 minutes</td> <td>Maximum temperature (85°C)</td> </tr> <tr> <td>30 minutes</td> <td>85°C → 25°C</td> </tr> </tbody> </table>	Consecutive Cycle	Temperature	10 minutes	25°C	30 minutes	25°C → -35°C	240 minutes	Minimum temperature(-35°C)	30 minutes	-35°C → 25°C	10 minutes	25°C	30 minutes	25°C → 85°C	240 minutes	Maximum temperature (85°C)	30 minutes	85°C → 25°C
Consecutive Cycle	Temperature																		
10 minutes	25°C																		
30 minutes	25°C → -35°C																		
240 minutes	Minimum temperature(-35°C)																		
30 minutes	-35°C → 25°C																		
10 minutes	25°C																		
30 minutes	25°C → 85°C																		
240 minutes	Maximum temperature (85°C)																		
30 minutes	85°C → 25°C																		
Vibration Test	The test has to be done for 2 hours or more under the Vibration amplitude at 1.5mm, Frequency at 10-5-10Hz, Sweep Time for 1 minute on the X, Y, Z direction each. Consequently there shall be no visual damage or inside characteristics.																		
Appearance Test	There shall be no contaminant or dust on the switching regulator, which affect any electrical characteristics. There shall be no severe unevenness or scratches on the plated or painted surface																		

7.2 Mean Time Between Failure (MTBF)

The product has been designed by 50,000 MTBF with 90% reliability index under below conditions.

- Input voltage : 12Vdc
- Duty cycle : 6hours ON, 2hours OFF
- Ambient Temp : $25 \pm 2^{\circ}\text{C}$
- Humidity : prevailing condition

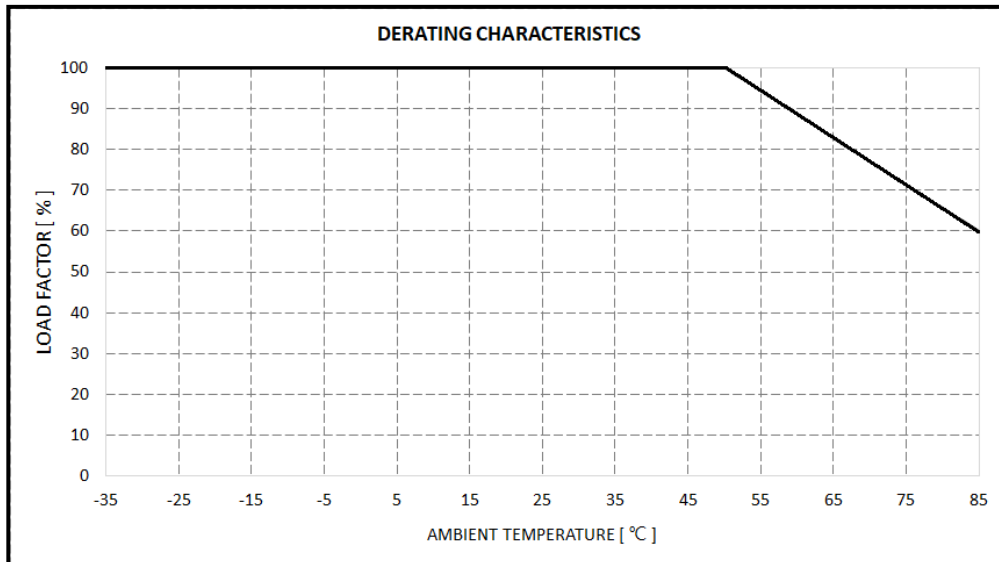

It measured by Lambda Predict Program, "Reliasoft" made. And it calculates by the Telcordia SR-332 Issue 3

The MTBF : **280,740** hours
(refer to the calculation data on the page 12)



Name: LED DRIVER [CVT-230]
 Failure Rate(t=INF) (FITs): 7110.2452
 Category: Telcordia SR-332 Issue 3
 User Name: Lee Eungak

Category	Location No.	Failure Rate(t=INF)	MTBF (hrs)	Contribution	Quantity
Capacitor	C100	123.3435	280,740	0.0354	1
Capacitor	C101	1.4578	5,144,600,000	4.00E-04	1
Capacitor	C102	108.4622	318,480	0.0311	1
Capacitor	C103	1.2373	808,190,000	4.00E-04	1
Capacitor	C104	0.5766	1,734,400,000	2.00E-04	1
Capacitor	C105	0.1266	7,898,300,000	3.63E-05	1
Capacitor	C106	0.1266	7,898,300,000	3.63E-05	1
Capacitor	C108	0.2813	3,554,300,000	8.07E-05	1
Capacitor	C200	0.9827	1,017,600,000	3.00E-04	1
Capacitor	C201	0.1729	5,783,700,000	4.96E-05	1
Capacitor	C202	0.1729	5,783,700,000	4.96E-05	1
Capacitor	C203	0.1729	5,783,700,000	4.96E-05	1
Capacitor	C204	0.1729	5,783,700,000	4.96E-05	1
Capacitor	C205	0.1271	7,866,000,000	3.65E-05	1
Capacitor	C206	0.4132	2,420,100,000	1.00E-04	1
Capacitor	C208	0.4132	2,420,100,000	1.00E-04	1
Capacitor	C209	0.4132	2,420,100,000	1.00E-04	1
Capacitor	C210	0.4132	2,420,100,000	1.00E-04	1
Connector	CN100	7.349	136,070,000	0.0021	1
Connector	CN101	7.349	136,070,000	0.0021	1
Connector	CN102	7.349	136,070,000	0.0021	1
Connector	CN103	7.349	136,070,000	0.0021	1
Connector	CN105	7.349	136,070,000	0.0021	1
Connector	CN200	7.349	136,070,000	0.0021	1
Diode	D101	609.9612	1,639,400	0.175	1
Diode	D100	609.9612	1,639,400	0.175	1
External	F100	-	-	0	1
IC, Analog/Linear	IC100	208.4981	4,796,200	0.0598	1
IC, Analog/Linear	IC200	90.4862	11,051,000	0.026	1
IC, Microcontroller	IC201	1356.6465	737,110	0.3893	1
Inductor	L100	13.2063	75,721,000	0.0038	1
Inductor	L101	13.2063	75,721,000	0.0038	1
External	LED1	-	-	0	1
External	LED2	-	-	0	1
External	PCB	-	-	0.00E+00	1
Resistor, Fixed	R104	1.1438	874,300,000	3.00E-04	1
Transistor	Q100	162.9446	6,137,100	4.68E-02	1
Transistor	Q200	92.0831	10,860,000	2.64E-02	1
Resistor, Fixed	R100	1.1438	874,300,000	3.00E-04	1
Resistor, Fixed	R101	1.1438	874,300,000	3.00E-04	1
Resistor, Fixed	R102	1.1438	874,300,000	3.00E-04	1
Resistor, Fixed	R103	1.1438	874,300,000	3.00E-04	1
Resistor, Fixed	R105	1.1438	874,300,000	3.00E-04	1
Resistor, Fixed	R106	1.1438	874,300,000	3.00E-04	1
Resistor, Fixed	R107	1.1438	874,300,000	3.00E-04	1
Resistor, Fixed	R108	1.1438	874,300,000	3.00E-04	1
Resistor, Fixed	R109	2.1347	468,450,000	6.00E-04	1
Resistor, Fixed	R110	1.1438	874,300,000	3.00E-04	1
Resistor, Fixed	R113	1.1438	874,300,000	3.00E-04	1
Resistor, Fixed	R114	1.1438	874,300,000	3.00E-04	1
Resistor, Fixed	R115	1.1438	874,300,000	3.00E-04	1
Resistor, Fixed	R116	1.1438	874,300,000	3.00E-04	1
Resistor, Fixed	R117	1.1438	874,300,000	3.00E-04	1
Resistor, Fixed	R118	1.1438	874,300,000	3.00E-04	1
Resistor, Fixed	R119	1.1438	874,300,000	3.00E-04	1
Resistor, Fixed	R120	1.1438	874,300,000	3.00E-04	1
Resistor, Fixed	R200	1.1438	874,300,000	3.00E-04	1
Resistor, Fixed	R201	1.1438	874,300,000	3.00E-04	1
Resistor, Fixed	R202	1.1438	874,300,000	3.00E-04	1
Resistor, Fixed	R203	1.1438	874,300,000	3.00E-04	1
Resistor, Fixed	R204	1.1438	874,300,000	3.00E-04	1
Resistor, Fixed	R205	1.1438	874,300,000	3.00E-04	1
Resistor, Fixed	R206	1.1438	874,300,000	3.00E-04	1
Resistor, Fixed	R207	1.1438	874,300,000	3.00E-04	1
Resistor, Fixed	R208	1.1438	874,300,000	3.00E-04	1
Resistor, Fixed	R209	1.1438	874,300,000	3.00E-04	1
Resistor, Fixed	R210	1.1438	874,300,000	3.00E-04	1
Resistor, Fixed	R211	1.1438	874,300,000	3.00E-04	1
Resistor, Fixed	R212	1.1438	874,300,000	3.00E-04	1
Resistor, Fixed	R214	1.1438	874,300,000	3.00E-04	1
Resistor, Fixed	R215	1.1438	874,300,000	3.00E-04	1
Resistor, Fixed	R216	1.1438	874,300,000	3.00E-04	1
Resistor, Fixed	R217	1.1438	874,300,000	3.00E-04	1
Resistor, Fixed	R218	1.1438	874,300,000	3.00E-04	1
Resistor, Fixed	R219	1.1438	874,300,000	3.00E-04	1
		Minimum	280,740		