

TL4415-BDNN+NW: WITH NUT AND WASHER  
 TL4415-BDNN+O: WITHOUT NUT AND PLATE, WASHER

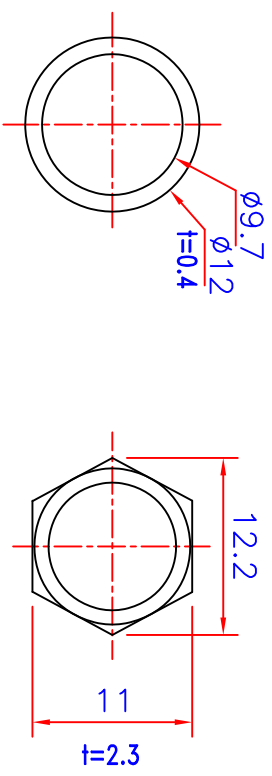
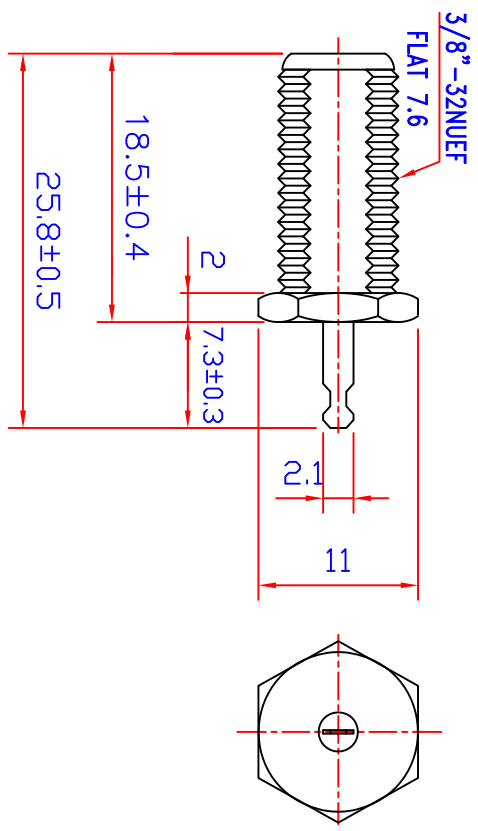
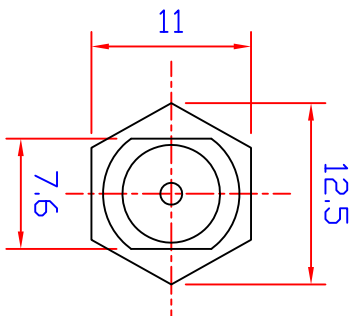

PIN 可以轉動的

WASHER

NUT

F FEMALE BULKHEAD

UNLESS OTHERWISE SPECIFIED  
 GENERAL TOLERANCES  
 0.5~6 = ±0.2  
 >6~30 = ±0.4  
 >30~120 = ±0.6

NO.	DESCRIPTION	QTY	MATERIAL	SPECIFICATION	REMARK
DRAW BY	CHUN	060210	SCALE	1 : 2	ITEM NO. TL4415-BDNN+NW
DEGN BY	YANG		UNIT	MM	TITLE F CONNECTORS
APPD BY	RAY				DWG NO. TL4415-BDNN+NW -TN06-A1

同利企業有限公司

TELE LONG ENTERPRISE CO.,LTD

DATE	DRAWG BY	REVISED
------	----------	---------

TL4415-BDNN+NP: WITH NUT AND PLATE 鎖上螺帽和接地片  
 TL4415-BDNN+O: WITHOUT NUT AND PLATE, WASHER

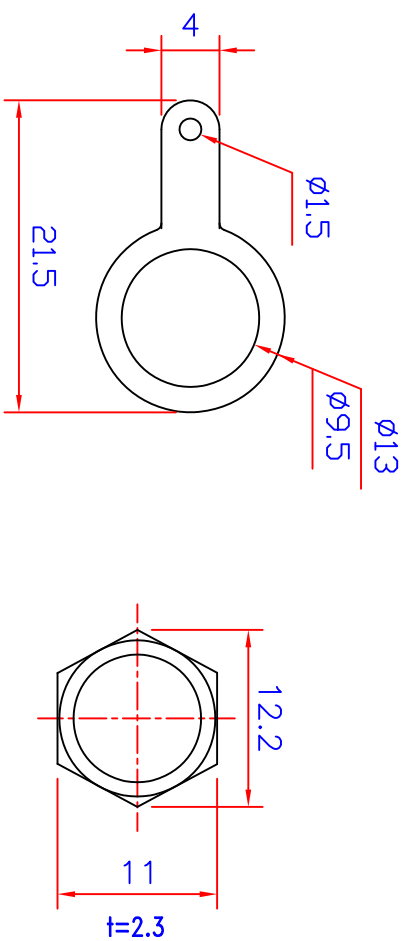
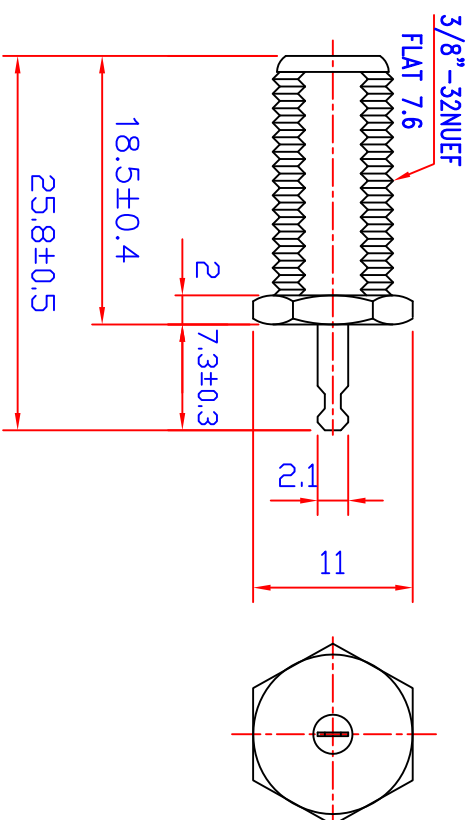
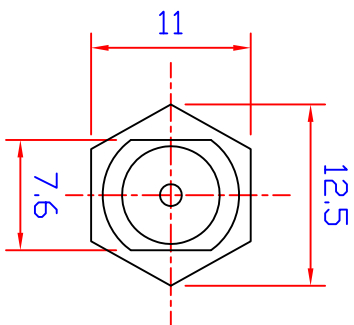

PIN 可以轉動的

PLATE

F FEMALE BULKHEAD

NUT

UNLESS OTHERWISE SPECIFIED  
 GENERAL TOLERANCES  
 0.5~6 = ±0.2  
 >6~30 = ±0.4  
 >30~120 = ±0.6

NO.	DESCRIPTION	QTY	MATERIAL	SPECIFICATION	REMARK
DRAW BY	CHUN	061010	SCALE	1 : 2	ITEM NO. TL4415-BDNN+NP
DEGN BY	YANG		UNIT	MM	TITLE F CONNECTORS
APPD BY	RAY				DWG NO. TL4415-BDNN+NP-TN06-A2

DATE	DRAWG BY	REVISED	同利企業有限公司	TELE LONG ENTERPRISE CO.,LTD
------	----------	---------	----------	------------------------------

TL4415-1-BDNN+NW: WITH NUT AND WASHER  
 TL4415-1-BDNN+O: WITHOUT NUT AND PLATE, WASHER

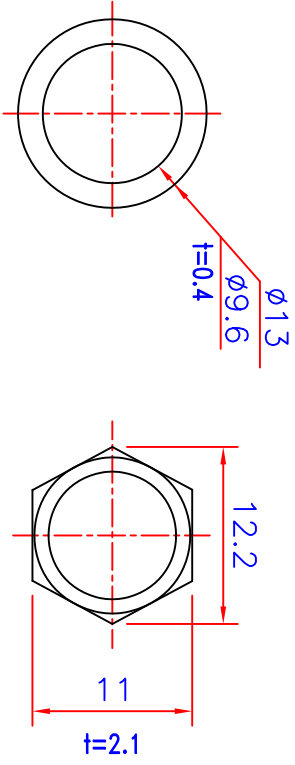
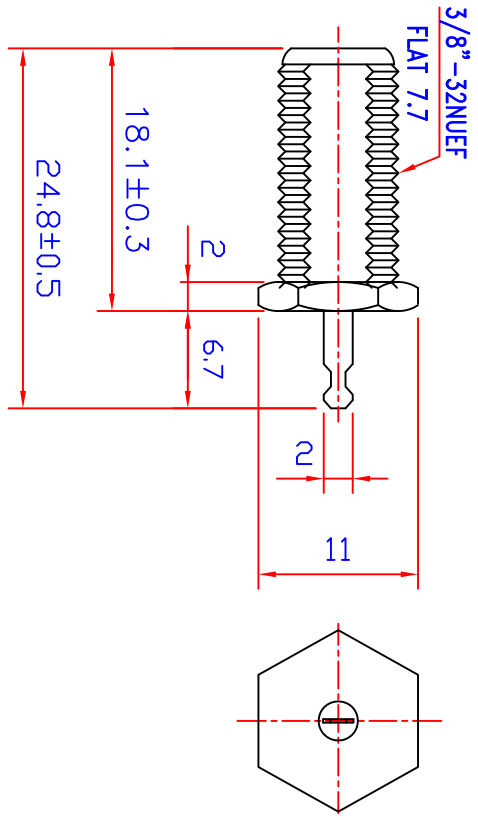
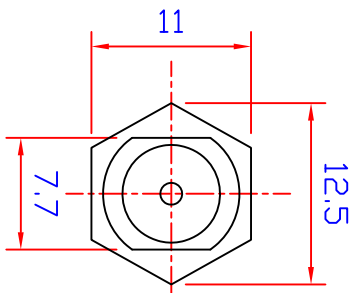

PIN 可以轉動的

WASHER

NUT

F FEMALE BULKHEAD

UNLESS OTHERWISE SPECIFIED  
 GENERAL TOLERANCES  
 0.5~6 = ±0.2  
 >6~30 = ±0.4  
 >30~120 = ±0.6

NO.	DESCRIPTION	QTY	MATERIAL	SPECIFICATION	REMARK
DRAW BY	CHUN	06D910	SCALE	1 : 2	ITEM NO. TL4415-1-BDNN+NW
DEGN BY	YANG		UNIT	MM	TITLE F CONNECTORS
APPD BY	RAY				DWG NO. TL4415-1-BDNN+NW-CN19-A1

同利企業有限公司

TELE LONG ENTERPRISE CO.,LTD

DATE	DRAWG BY	REVISED
------	----------	---------

TL4415-1-BDNN+NP: WITH NUT AND PLATE  
 TL4415-1-BDNN+O: WITHOUT NUT AND PLATE, WASHER

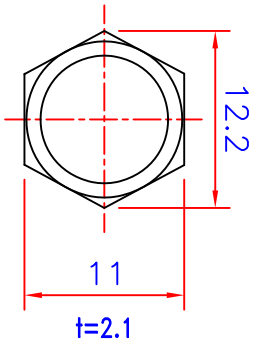
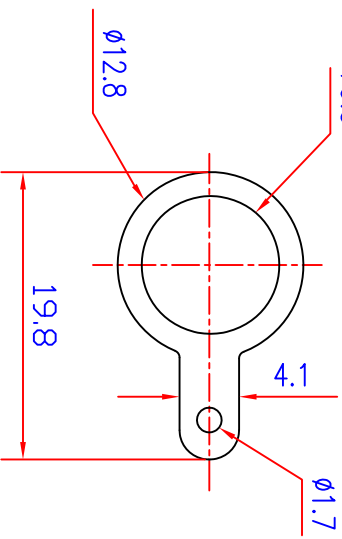
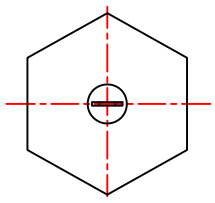
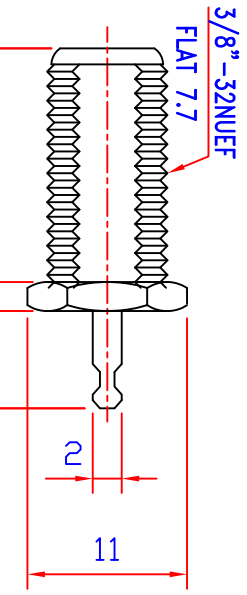
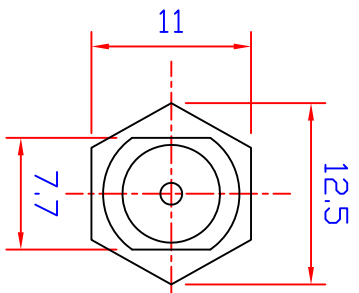

PIN 可以轉動的

接地片 PLATE

NUT

F FEMALE BULKHEAD

UNLESS OTHERWISE SPECIFIED  
 GENERAL TOLERANCES  
 0.5~6 = ±0.2  
 >6~30 = ±0.4  
 >30~120 = ±0.6

NO.	DESCRIPTION	QTY	MATERIAL	SPECIFICATION	REMARK
DRAW BY	CHUN	06D910	1 : 2		ITEM NO. TL4415-1-BDNN+NP
DEGN BY	YANG				TITLE F CONNECTORS
APPD BY	RAY				

同利企業有限公司

TELE LONG ENTERPRISE CO.,LTD

DATE	DRAWG BY	REVISED
------	----------	---------

DWG NO.	TL4415-1-BDNN+NP -CN19-A1
---------	------------------------------

TL4415-3-BDNN+NP: WITH NUT AND PLATE  
 TL4415-3-BDNN+O: WITHOUT NUT AND PLATE

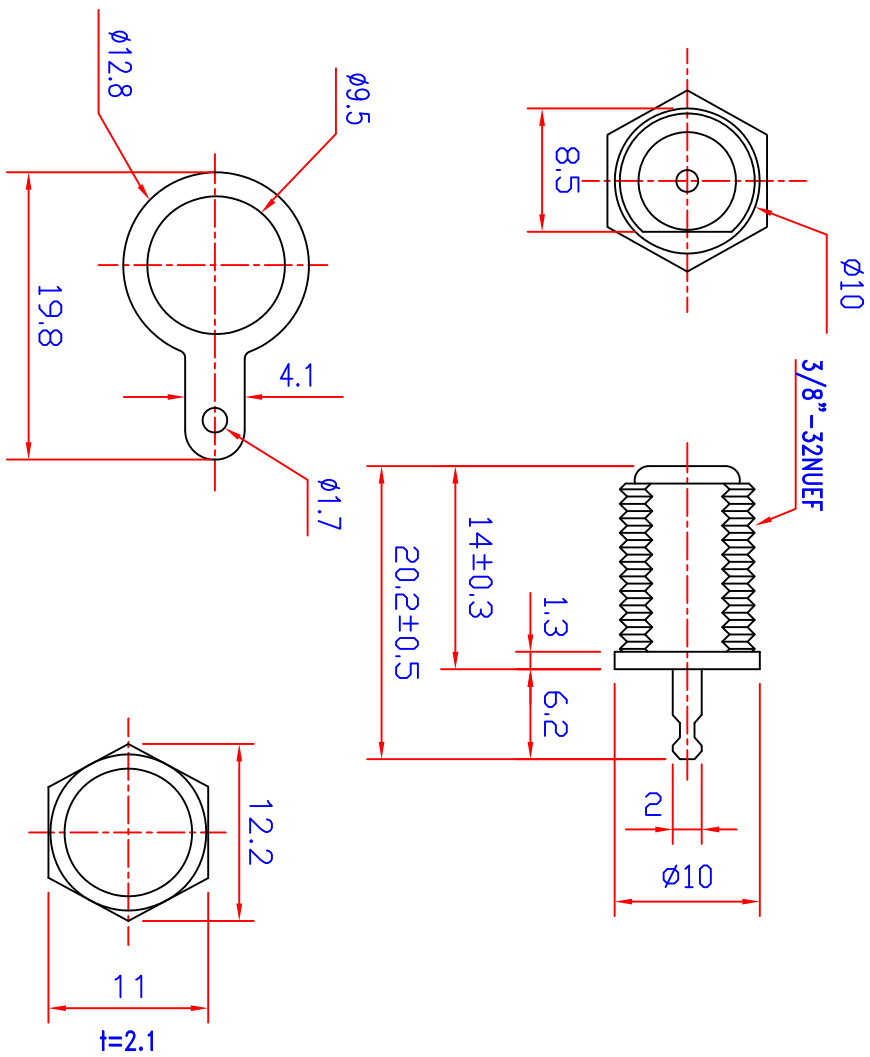

PIN 可以轉動的

接地片 PLATE

NUT

F FEMALE BULKHEAD

UNLESS OTHERWISE SPECIFIED  
 GENERAL TOLERANCES  
 0.5~6 = ±0.2  
 >6~30 = ±0.4  
 >30~120 = ±0.6

NO.	DESCRIPTION	QTY	MATERIAL	SPECIFICATION	REMARK
DRAW BY	CHUN	06D910	SCALE	1 : 2	ITEM NO. TL4415-3-BDNN+NP
DEGN BY	YANG		UNIT	MM	TITLE F CONNECTORS
APPD BY	RAY				DWG NO. TL4415-3-BDNN+NP-CN19-A1

同利企業有限公司

TELE LONG ENTERPRISE CO.,LTD

DATE	DRAWG BY	REVISED
------	----------	---------