

SPECIFICATION

[] Preliminary Specification
 [] Final Specification

Description **10.4” 800xRGBx600 TFT-LCD Module**
Part Number **P1040SVF1ME00**

Customer	Industrial Product Dept, PDBU Tianma Microelectronics Co., Ltd.		
Signatures	Date	Approved By	Date
_____	_____	_____	_____
_____	_____	Reviewed By	_____
		Longping.Deng	2023-8-21
		Prepared By	_____
		Gang.li	2023-5-31
Comments:			

* This cover page is for your Comments and Signatures back to TIANMA.

CONTENTS

1. SUMMARY	1
1.1 General Description.....	1
1.2 Features.....	1
2. GENERAL SPECIFICATIONS	2
3. INPUT / OUTPUT TERMINALS	3
3.1 CN1 Pin assignment (LCD Interface).....	3
3.2 CN2 Pin assignment (Back Light).....	4
4. ABSOLUTE MAXIMUM RATINGS	5
5. ELECTRICAL CHARACTERISTICS	6
5.1 DC Characteristics for Panel Driving.....	6
5.2 DC Characteristics for Backlight Driving.....	7
5.3 Recommended Power ON/OFF Sequence.....	8
5.4 LCD Module Block Diagram.....	9
6. TIMING CHARACTERISTICS	10
6.1 AC characteristics.....	10
6.2 Data Input Timing Parameter Setting.....	11
6.3 LVDS data mapping.....	12
7. OPTICAL CHARACTERISTICS	13
8. RELIABILITY TEST	16
9. MECHANICAL DRAWING	17
10. PACKING INSTRUCTION	18
11. PRECAUTIONS FOR USE OF LCD MODULES	20
11.1 Handling Precautions.....	20
11.2 Storage precautions.....	20
11.3 Transportation Precautions	20
11.4 Screen saver Precautions.....	20
11.5 Safety Precautions	20

1. Summary

1.1 General Description

This is a 10.4 inch a-Si TFT-LCD module with Normal-Black technology. It is composed of a TFT-LCD panel, a driver circuit, PCB, and a LED backlight unit.

1.2 Features

- Ultra-wide viewing angle (Super Fine TFT (SFT))
- 50Khrs Long LED life time
- Interface: 1 port LVDS
- Without LED driver
- Surface treatment: AG
- Acquisition product for UL62368-1/CSA C22.2 No.62368-1-03 (File number: E333987)
- Compliant with the European RoHS Directive (2011/65/EU) and Delegated Directive (2015/863/EU, Amending Annex II of 2011/65/EU)

2. General Specifications

	Feature	Spec	Unit
Display Spec	Size	10.4 inches	
	Resolution	800(RGB)x600	
	Pixel Pitch	0.264x0.264	mm
	TFT Active Area	211.20x158.40	mm
	Technology Type	a-Si	
	Pixel Configuration	R.G.B Vertical Stripe	
	Display Mode	SFT, Normally Black	
	Surface Treatment	Anti-Glare	
	Viewing Direction	ALL	
Mechanical Characteristics	LCM (W x H x D)	236.0x176.9x5.92	mm
	Weight	313	g
Optical Characteristics	Luminance	400	cd/m ²
	Contrast Ratio	1000:1	
	NTSC	50	%
	Viewing Angle	88/88/88/88	degree
Electrical Characteristics	Interface	1 port LVDS	
	Color Depth	262K	color
	Power Consumption	LCD: 435 Backlight: 2160	mW

Table 2.1 General TFT Specifications

3. Input / Output Terminals

3.1 CN1 Pin assignment (LCD Interface)

Connector Information	
LCD Module connector	Hirose DF19K-20P-1H
Matching connector	Hirose DF19-20S-1C or equivalent

Table 3.1.1 Connector information

No	Symbol	I/O	Description	Comment
1	VDD	P	Power Supply	
2	VDD	P	Power Supply	
3	GND	P	Ground	
4	GND	P	Ground	
5	IN0-	I	LVDS receiver negative signal channel 0	
6	IN0+	I	LVDS receiver positive signal channel 0	
7	GND	P	Ground	
8	IN1-	I	LVDS receiver negative signal channel 1	
9	IN1+	I	LVDS receiver positive signal channel 1	
10	GND	P	Ground	
11	IN2-	I	LVDS receiver negative signal channel 2	
12	IN2+	I	LVDS receiver positive signal channel 2	
13	GND	P	Ground	
14	CLK-	I	LVDS receiver negative signal clock	
15	CLK+	I	LVDS receiver positive signal clock	
16	GND	P	Ground	
17	NC	-	No connection	
18	NC	-	No connection	
19	GND	P	Ground	
20	GND	P	Ground	

Table 3.1.2 Pin Assignment for LCD Interface

Note1: I/O definition: I---Input, O---Output, P---Power/Ground, N---No connection

Note2: All of the GND pins should be connected to the system ground.

Note3: Display direction:



3.2 CN2 Pin assignment (Back Light)

Connector Information	
LCD Module connector	JST BHSR-02VS-1
Matching connector	JST SM02B-BHSS-1-TB or equivalent

Table 3.2.1 Connector information

No	Symbol	I/O	Description	Wire Color
1	LEDA	P	LED driving anode (high voltage)	Red
2	LEDK	P	LED driving cathode (low voltage)	White

Table 3.2.2 Pin Assignment for Back Light Interface

Note1: I/O definition: I---Input, O---Output, P---Power/Ground, N---No connection

Note2: All of the GND pins should be connected to the system ground.

4. Absolute Maximum Ratings

Item	Symbol	MIN	MAX	Unit	Remark
Power Voltage	VDD	-0.3	3.96	V	Note1
Operating Temperature	Top	-20	70	°C	
Storage Temperature	Tst	-30	80	°C	
Relative Humidity Note2	RH	--	≤95	%	Ta≤40°C
		--	≤85	%	40°C < Ta≤50°C
		--	≤55	%	50°C < Ta≤60°C
		--	≤36	%	60°C < Ta≤70°C
		--	≤24	%	70°C < Ta≤80°C
Absolute Humidity	AH	--	≤70	g/m ³	Ta>70°C

Table 4.1 Absolute Maximum Ratings

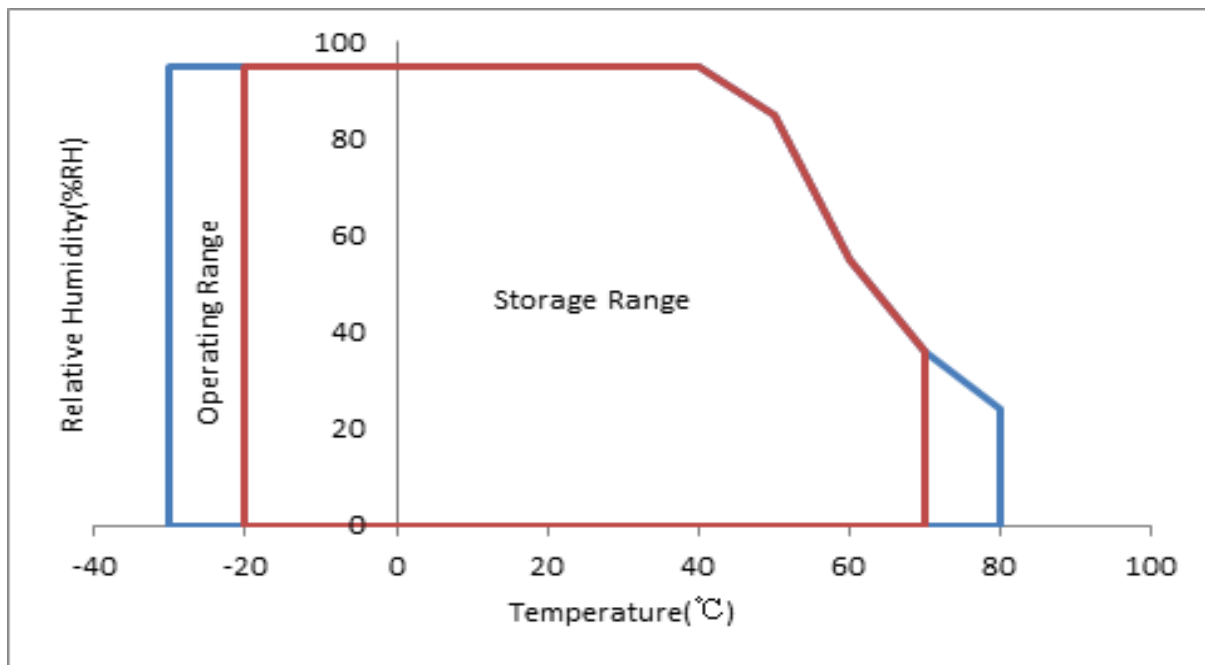

Figure 4.2 Absolute Maximum Ratings chart

Note1: Input voltage include all input data.

Note2: Ta means the ambient temperature. It is necessary to limit the relative humidity to the specified temperature range. Condensation on the module is not allowed.

Note3: The absolute maximum rating values of this product are not allowed to be exceeded at any times. A module should be used with any of the absolute maximum ratings exceeded, the characteristics of the module may not be recovered, or in an extreme condition, the module may be permanently destroyed

5. Electrical Characteristics

5.1 DC Characteristics for Panel Driving

Item	Symbol	MIN	TYP	MAX	Unit	Remark	
Supply Voltage	VDD	3.0	3.3	3.6	V	Include ripple	
LVDS Differential input high threshold	R_{xvth}	--	--	+37	mV		
LVDS Differential input low threshold	R_{xvtl}	-37	--	--	mV		
Differential input voltage	$ V_{ID} $	0.1	--	0.4	V		
LVDS input common mode voltage	R_{xvcm}	600	1200	1375	mV	$R_{xvcm} + 1/2 * V_{ID} \leq 1650mV$ $R_{xvcm} - 1/2 * V_{ID} \geq 400mV$	
Power Consumption	60Hz	P_{VDD}	--	435	--	mW	white pattern
VDD rush current	I_{rush}	--	--	1.5	A		

Table 5.1.1 Operating Voltages

Note1: LVDS DC characteristics.

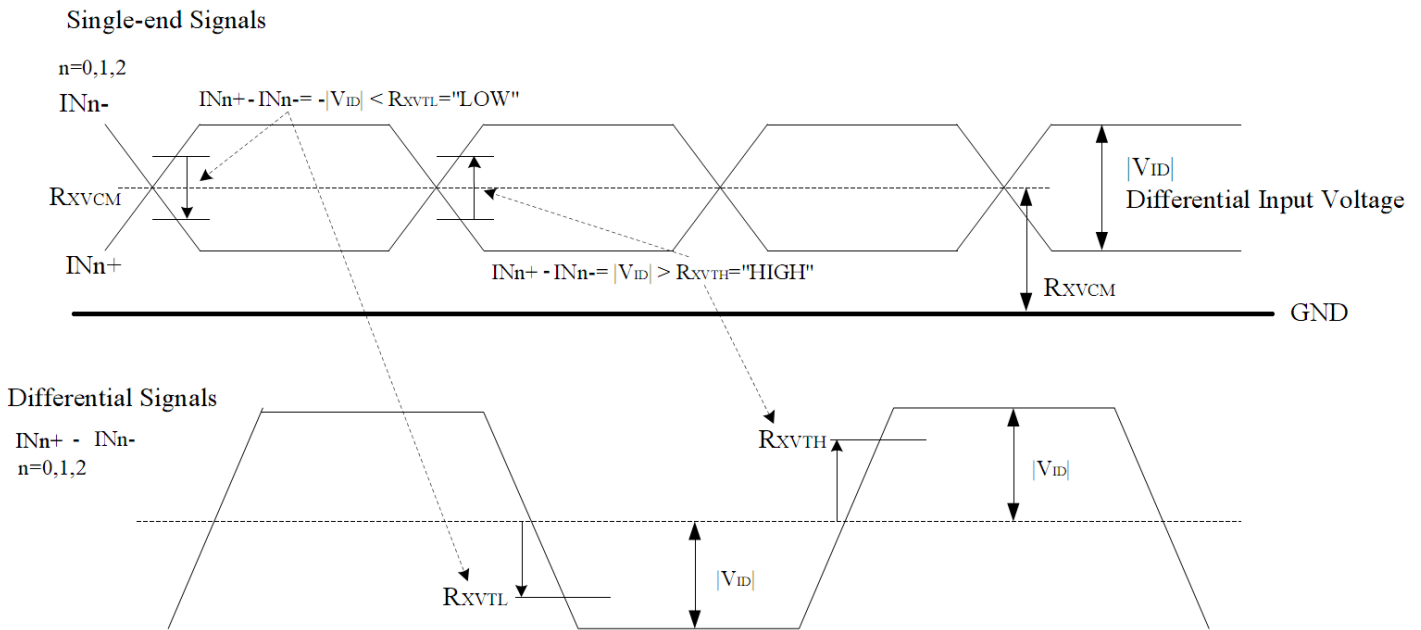

Note2: Inrush current test condition.

VDD rising time is 470μs

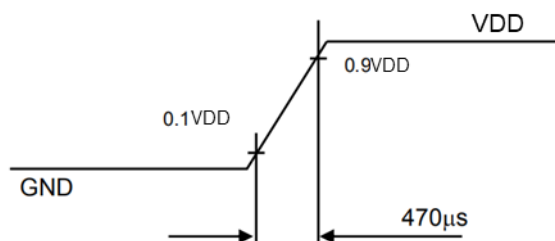

5.2 DC Characteristics for Backlight Driving

Item	Symbol	MIN	TYP	MAX	Unit	Remark
Forward Current	IF	--	120	--	mA	36 LEDs (6S6P)
Forward Current Voltage	VF	16.8	18.0	19.2	V	
Backlight Power Consumption	WBL	--	2160	--	mW	
LED life time	--	30000	50000	--	Hrs	

Table 5.2.1 LED Backlight Characteristics

Note1: I_F is defined for total channel.

Note2: Optical performance should be evaluated at $T_a=25^\circ\text{C}$ only.

Note3: If LED is driven by high current, high ambient temperature & humidity condition. The life time of LED will be reduced.

Note4: Operating life means brightness goes down to 50% of initial brightness. Typical operating life time is estimated data.

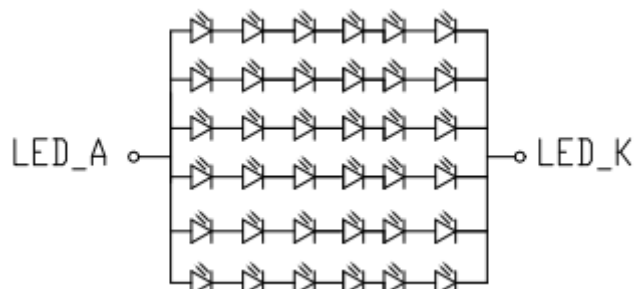

Figure 5.2 LED circuit

5.3 Recommended Power ON/OFF Sequence

Item	Symbol	Min	Typ	Max	Unit	Remark
VDD 10% to VDD 90%	Tp0	1	-	5	ms	
VDD to signal starting	Tp1	20	-	50	ms	
Signal starting to backlight on	Tp2	200	-	-	ms	
Signal off to VDD	Tp3	50	-	100	ms	
Backlight off to signal off	Tp4	200	-	-	ms	
To next VDD	Tp5	2	-	-	S	

Table 5.3.1 Power on/off sequence

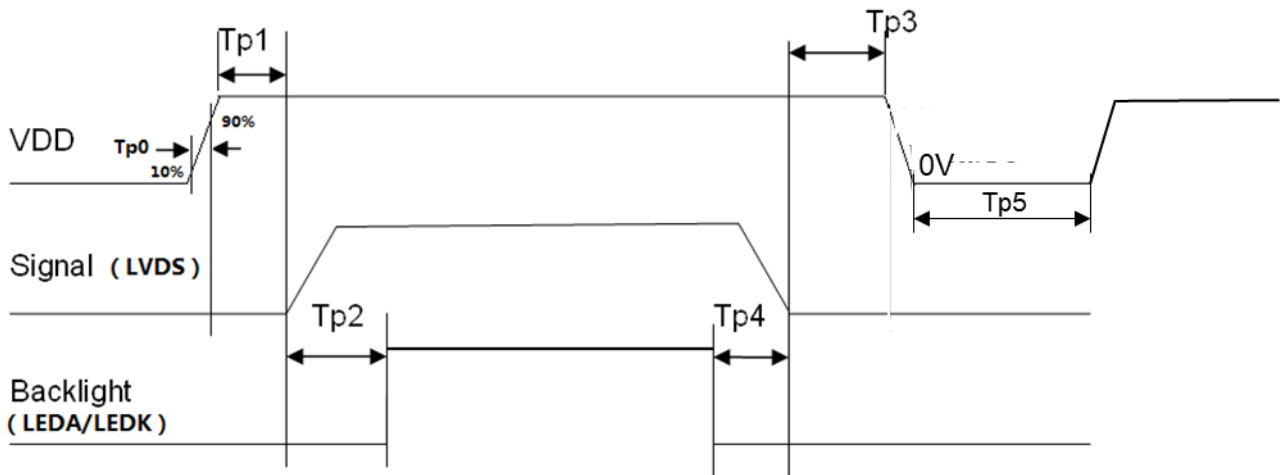

Figure 5.3.1 Power on/off sequence

Note1: The low level of these signals and analog powers are GND level.

Note2: All of the power and signals should be kept at GND level before power on. If there are residual voltages on them, the LCD might not work properly.

Note3: The power on/off sequence is the first version. It will be updated when the design is fixed.

Note4: LEDA/K is the voltage applied to backlight. Keep it turned off until the display has stabilized.

5.4 LCD Module Block Diagram

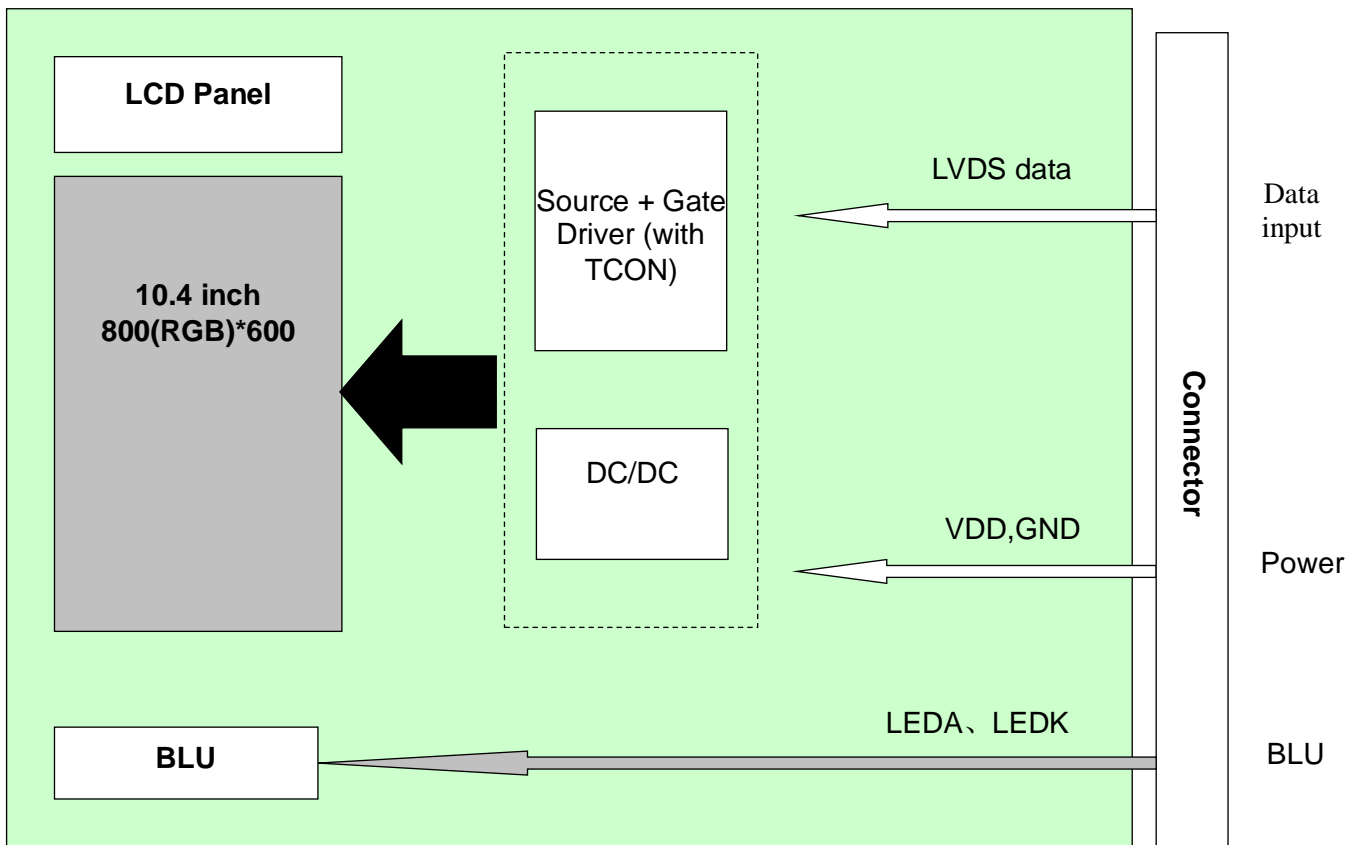

Figure 5.4.1 LCD Module Block Diagram

6. Timing Characteristics

6.1 AC characteristics

Parameter	Symbol	Min	Typ	Max	Unit	Remark
Dclk Frequency	RXFCLK	33.1	-	62.4	MHZ	
Input Data Skew Margin	TRSKM	-0.2	-	0.2	UI	VID = 200mV RxVCM = 1.2V 1UI=1/(RxFCLKx7)
Clock High Time	TLVCH	-	3.5/(7*RXFCLK)	-	ns	
Clock Low Time	TLVCL	-	3.5/(7*RXFCLK)	-	ns	
PLL Wake-up Time	TemPLL	-	-	150	us	

Table 6.1.1 AC characteristics

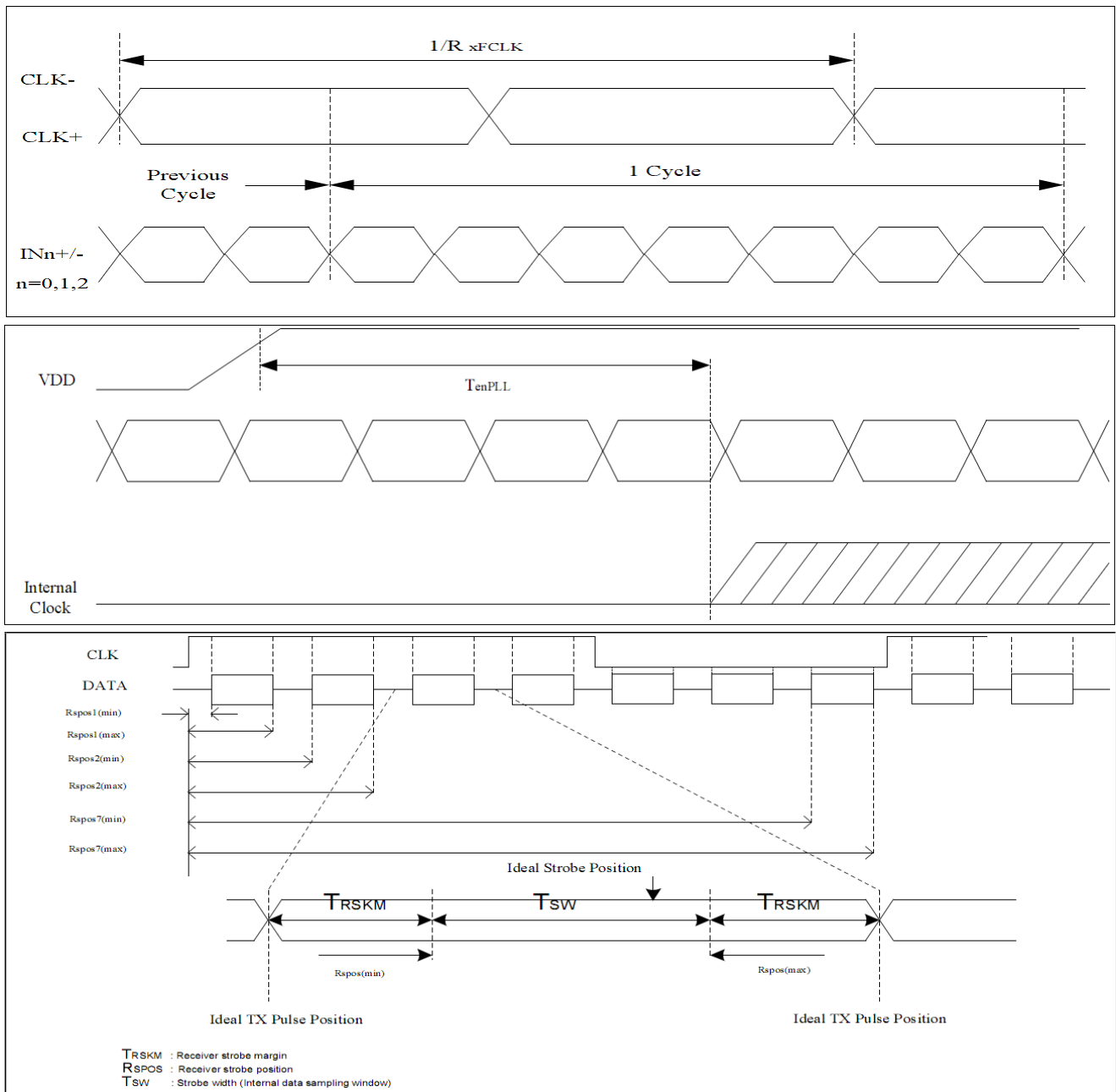

Figure 6.1.1 AC characteristics

6.2 Data Input Timing Parameter Setting

Parameter		Symbol	Min.	Typ.	Max.	Unit	Remark
DCLK frequency		Fclk	33.1	39.6	62.4	MHz	Tclk=1/Fclk
Horizontal section	Horizontal total	TH	890	1000	1300	Tclk	
	Horizontal blanking	THC	90	200	500	Tclk	
	Valid Data Width	THD	800			Tclk	
Vertical section	Vertical total	TV	620	660	800	TH	
	Vertical blanking	TVC	20	60	200	TH	
	Valid Data Width	TVD	600			TH	
Frame Rate		F	60			HZ	

Table 6.2.1 Data Input Timing Parameters

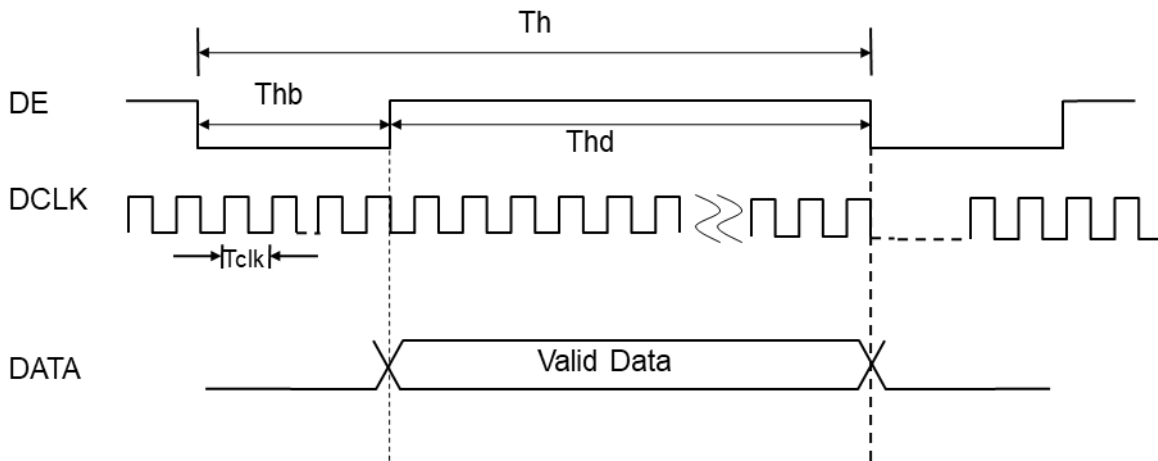
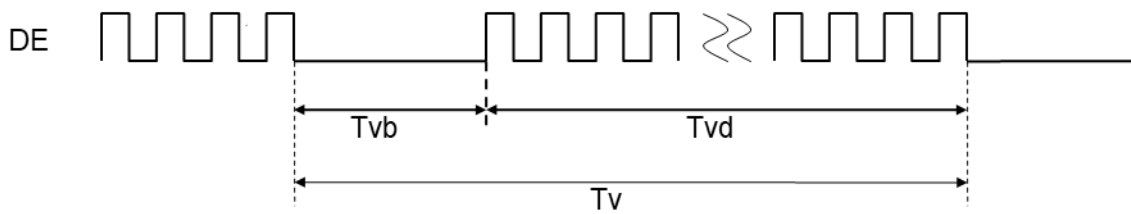

Figure 6.2.1 Data Input Timing

6.3 LVDS data mapping

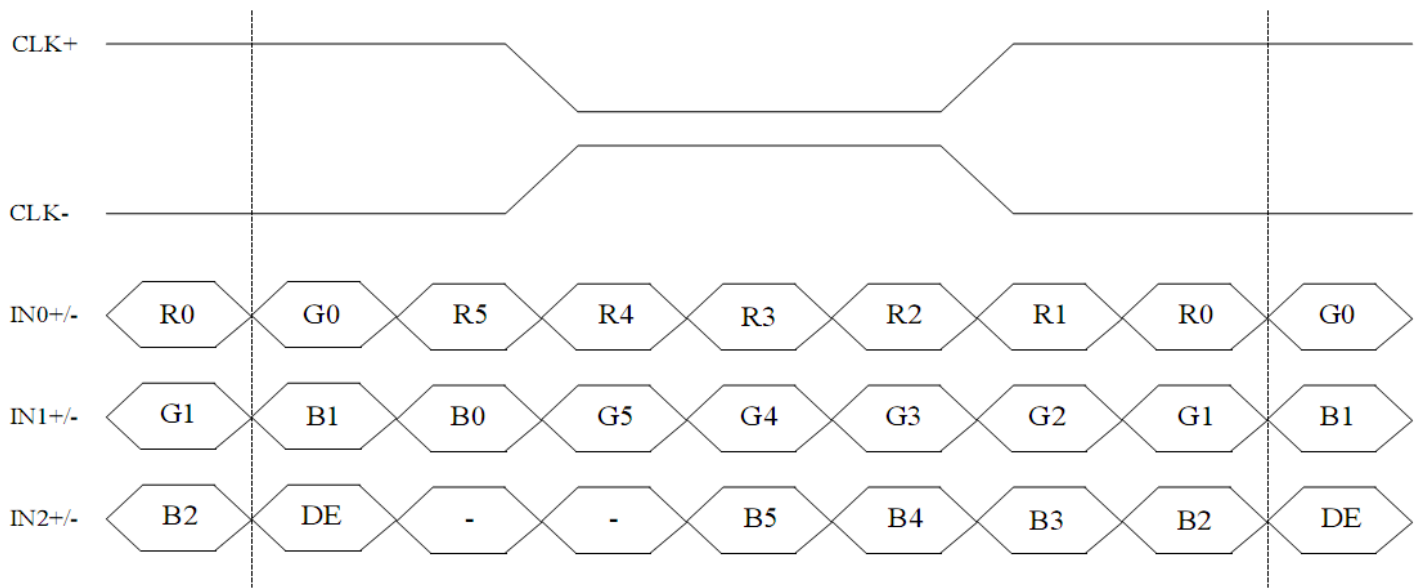

Figure 6.3.1 LVDS data mapping (VESA standard)

7. Optical Characteristics

Item	Symbol	Condition	Min	Typ	Max	Unit	Remark
View Angles	θT	$CR \geq 10$	78	88	--	degree	Note2,3
	θB		78	88	--		
	θL		78	88	--		
	θR		78	88	--		
Contrast Ratio	CR	$\theta=0^\circ$	1000	1200	--		Note 3
Response Time	T_{ON}	25°C	--	35	45	ms	Note 4
	T_{OFF}						
Chromaticity	White	Backlight is on	x	0.255	0.305	0.355	Note 1,5
			y	0.285	0.335	0.385	
	Red		x	0.549	0.599	0.649	Note 1,5
			y	0.273	0.323	0.373	
	Green		x	0.285	0.335	0.385	Note 1,5
			y	0.543	0.593	0.643	
	Blue		x	0.102	0.152	0.202	Note 1,5
			y	0.065	0.115	0.165	
Uniformity	U		75	80	--	%	Note 6
NTSC	-		45	50	--	%	Note 5
Luminance	L		350	400		cd/m ²	Note 7

Table 7.1 Optical Parameters

Test Conditions:

1. $I_F = 120$ mA, and the ambient temperature is 25°C.
2. The test systems refer to Note1 and Note2.

Note1: Definition of optical measurement system.

The optical characteristics should be measured in dark room. The optical characteristics are measured at the center point of the LCD screen.

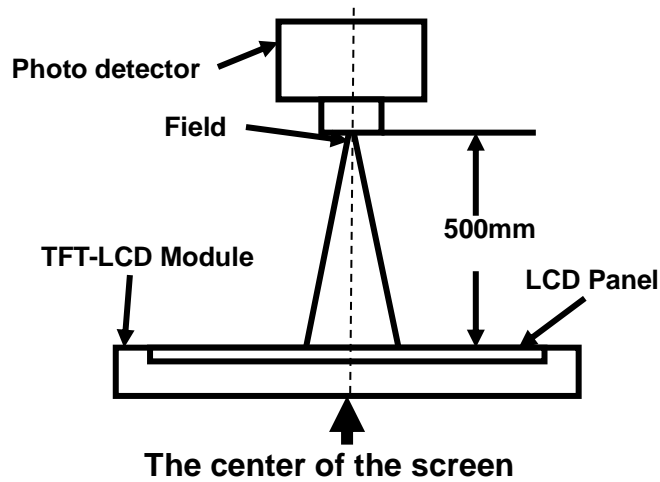

Fig1. Measurement Set Up

Note2: Definition of viewing angle range and measurement system. Viewing angle is measured at the center point of the LCD .

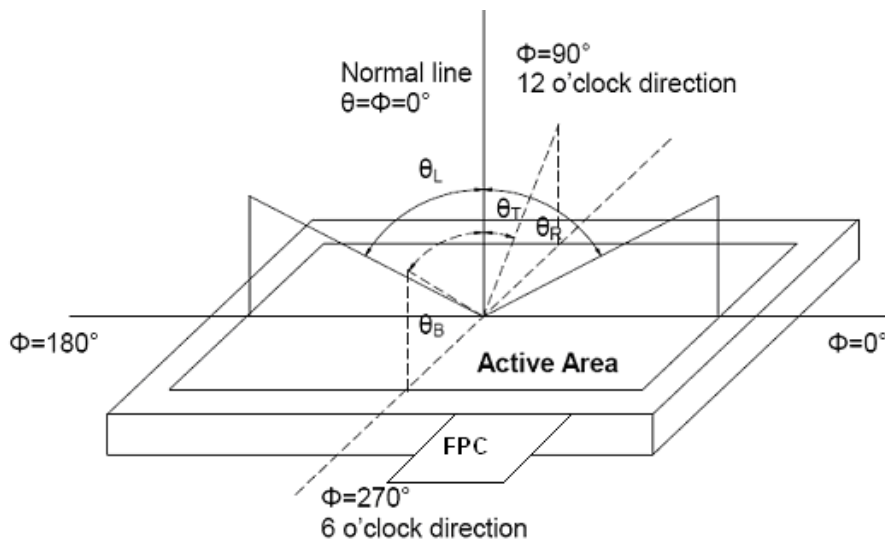

Fig2. Measurement viewing angle

Note3: Definition of contrast ratio

$$\text{Contrast ratio (CR)} = \frac{\text{Luminance measured when LCD is on the "White" state}}{\text{Luminance measured when LCD is on the "Black" state}}$$

Note4: Definition of Response time

The response time is defined as the LCD optical switching time interval between “White” state and “Black” state. Rise time (T_r) is the time between photo detector output intensity changed from 10% to 90%. And fall time (T_f) is the time between photo detector output intensity changed from 90% to 10%.

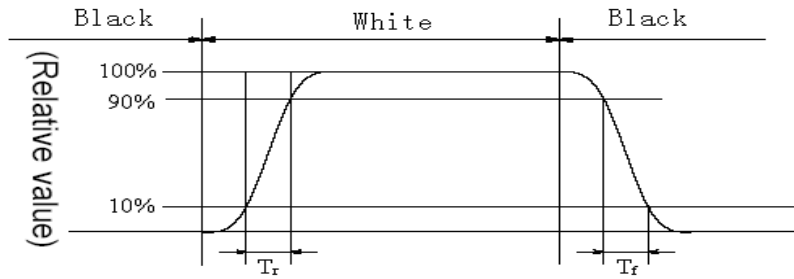

Fig4. Response Time Testing

Note5: Definition of color chromaticity (CIE1931)

Color coordinates measured at center point of LCD.

Note6: Definition of Luminance Uniformity

Active area is divided into 9 measuring areas (Refer Fig.5). Every measuring point is placed at the center of each measuring area.

Luminance Uniformity (U) = L_{min} / L_{max}

L_{max} : The measured Maximum luminance of all measurement position.

L_{min} : The measured Minimum luminance of all measurement position.

L-----Active area length; W----- Active area width

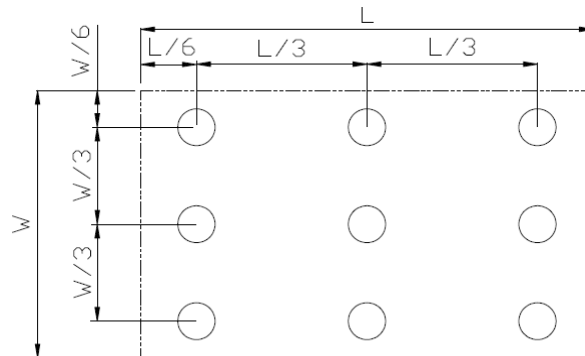

Fig5. Luminance Uniformity Measurement Locations (9 points)

Note7: Definition of Luminance:

Measure the luminance of white state at center point.

8. Reliability Test

No	Test Item	Condition	Remarks
1	High Temperature Operation	+70℃ , 240H	IEC60068-2-1:2007 GB2423.2-2008
2	Low Temperature Operation	-20℃ , 240H	IEC60068-2-1:2007 GB2423.1-2008
3	High Temperature Storage	+80℃ , 240H	IEC60068-2-1:2007 GB2423.2-2008
4	Low Temperature Storage	-30℃ , 240H	IEC60068-2-1:2007 GB2423.1-2008
5	Storage at High Temperature and Humidity(non-operation)	+60℃ , 90%RH , 240H	IEC60068-2-78 :2001 GB/T2423.3—2006
6	Thermal Shock (non-operation)	-30℃ , 30min~80℃ , 30min , change time : 5min , 100cycle	Start with cold temperature, End with high temperature, IEC60068-2-14:1984,GB2423.22-2002
7	ESD	C=150pF , R=330Ω , 5point/panel Air : ±15kv , 5times ; Contact : ±8kv , 5times ; (Environment : 15℃~35℃ , 30%~60% , 86Kpa~106Kpa)	IEC61000-4-2:2001 GB/T17626.2-2006
8	Vibration(non-operation)	Frequency range:10~55Hz Stroke:1.5mm Sweep:10Hz~55Hz~10Hz 2 hours for each direction of X.Y.Z. (6 hours for total)	IEC60068-2-6:1982 GB/T2423.10—1995
9	Shock(non-operation)	Half Sine Wave 60G 6ms, ±X,±Y,±Z 3times for each direction	IEC60068-2-27:1987 GB/T2423.5—1995
10	Package Vibration	5-20-200HZ , PSD : 0.01-0.01-0.001 Total:0.781g ² /HZ, x/y/z 30min)	IEC60068-2-34 GB/T2423.11
11	Package Drop Test	Height: 60 cm,1 corner, 3 edges, 6 surfaces	IEC60068-2-32:1990 GB/T2423.8—1995

Table 8.1 RA test condition

Note1: Temperature is the ambient temperature of sample

Note2: Before cosmetic and function test, the product must have enough recovery time, at least 24 hours at room temperature.

Note3: In the standard condition, there shall be no practical problem that may affect the display function. After the reliability test, the product's function only be guaranteed, but not for all of the cosmetic specification.

9. Mechanical Drawing

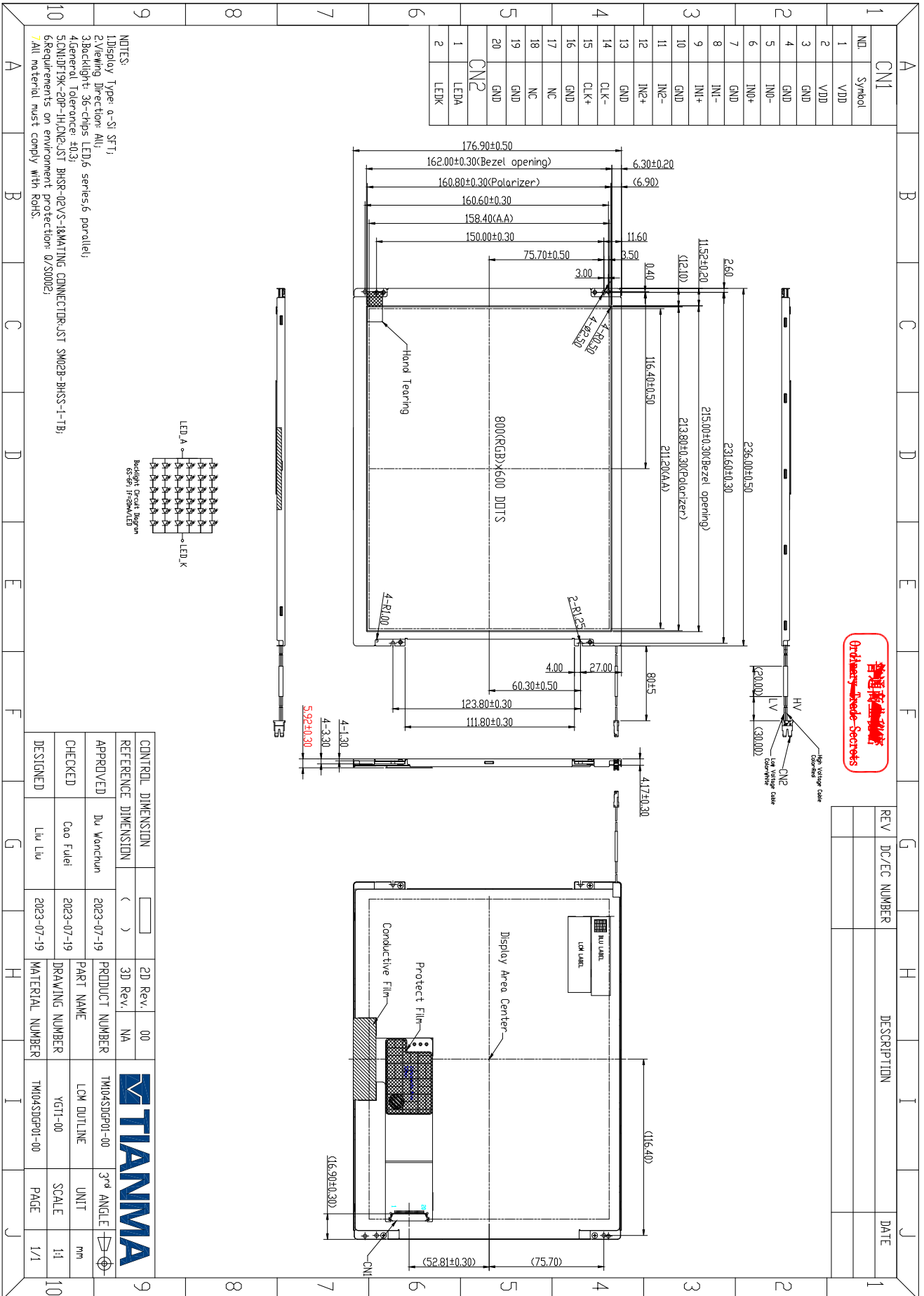

10. Packing Instruction

No	Item	Model (Material)	Dimensions(m m)	Unit Weight(Kg)	Q'ty	Remark
1	LCM module	P0104SVF1MB00	236.0x176.9x5.92	0.313	24	
2	Tray	PET	485x330x19	0.215	15	
3	BOX	CORRUGATED PAPER	520x345x74	0.44	3	
4	Dust proof bag	LD-PE	700x545x0.05	0.046	1	
5	Label	Tagboard	100x52	0.002	1	
6	Masking tape	PE	28x10	24		
7	Carton	CORRUGATED PAPER	544x365x250	1.01	1	
8	Total Weight	13.14Kg±5%				

Table 10.1 Packing Instruction

Packing procedure:

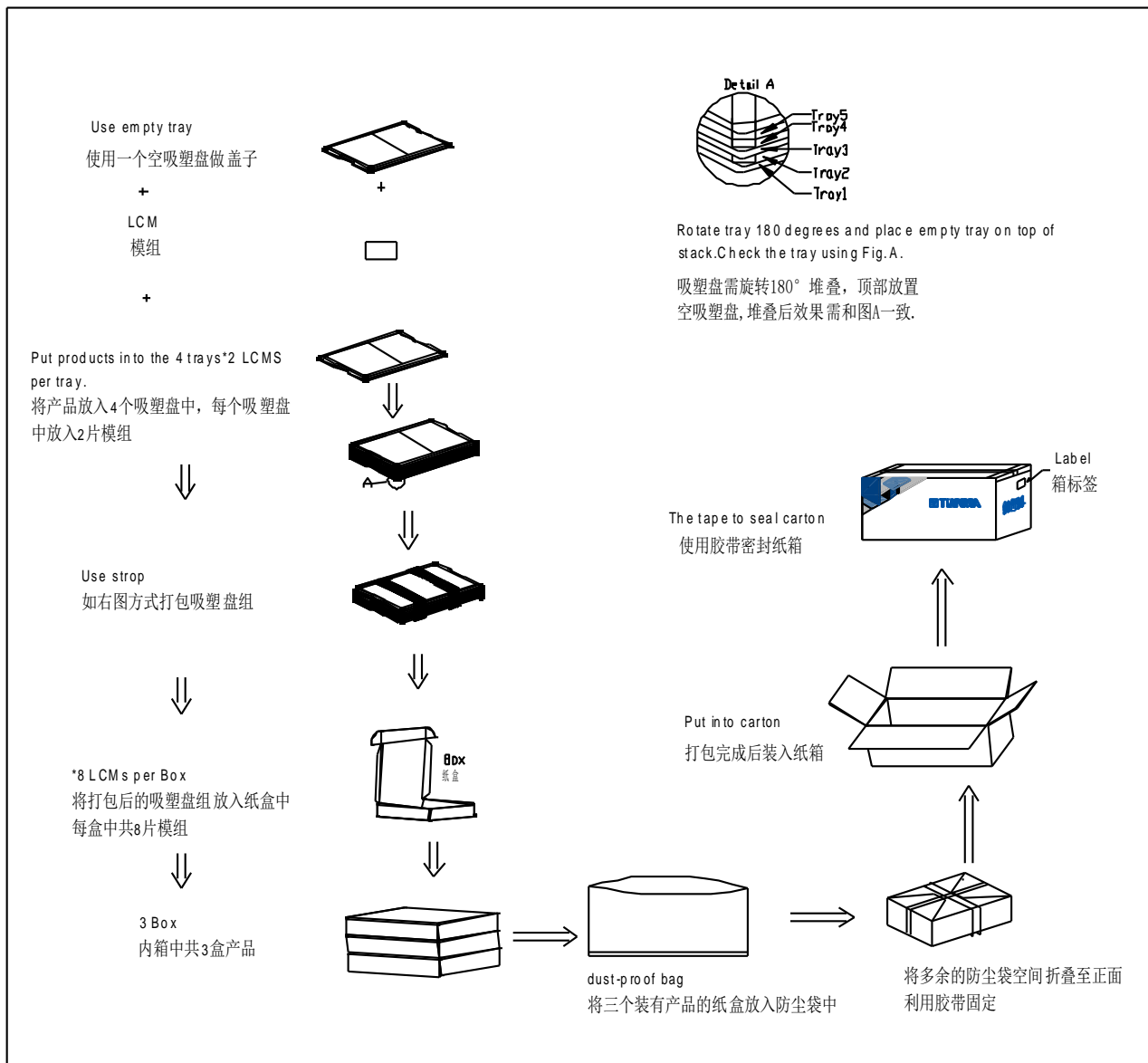

Cargo on pallet: Carton number is 2x3x5, pallet dimension is 1100mm x1100mm.

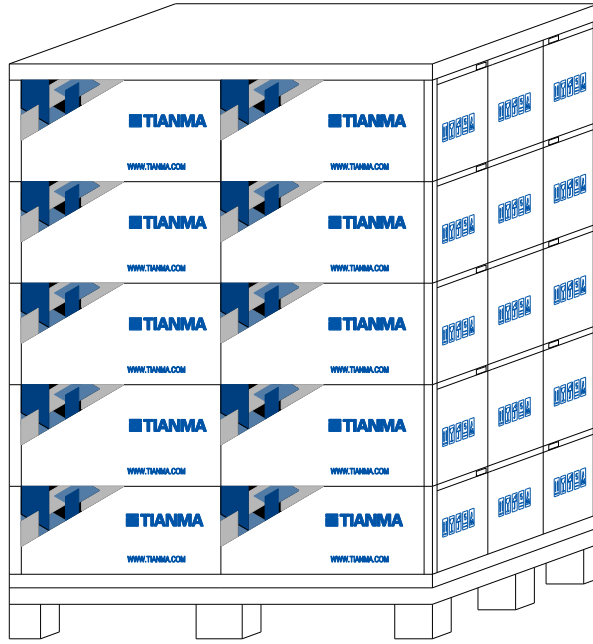

11. Precautions for Use of LCD Modules

11.1 Handling Precautions

- (1) The display panel is made of glass. Do not subject it to mechanical shock by dropping it, etc.
- (2) If the display panel is damaged and the liquid crystal fluid inside it leaks out be sure not to get any in your mouth. If the fluid comes into contact with your skin or clothes promptly wash it off using soap and water.
- (3) Do not apply excessive force to the display surface or the bezel since this may cause the color tone to vary.
- (4) The polarizer covering the display surface of the LCD module is soft and easily scratched. Handle the polarizer carefully.
- (5) If the display surface is contaminated, breathe on the surface and gently wipe it with a soft dry cloth. If it is still not completely clear use a moist cloth with one of the following solvents:
 - Isopropyl alcohol
 - Ethyl alcoholSolvents other than those mentioned above may damage the polarizer. Specifically, do not use the following:
 - Water
 - Ketone
 - Aromatic solvents
- (6) Do not disassemble the LCD Module.
- (7) If powered off, do not apply the input signals.
- (8) To prevent destruction of the module by static electricity, be careful to maintain an optimum work environment.
- (9) Be sure to ground your body when handling the LCD Modules.
- (10) Tools used for assembly, must be properly grounded.
- (11) To reduce the amount of static electricity generated, do not conduct assembly or other work under very low humidity conditions.
- (12) The LCD Module is covered with a film to protect the display surface, remove film slowly under the ionizer.

11.2 Storage precautions

- (1) When storing the LCD modules avoid exposure to direct sunlight or to the light of fluorescent lamps.
- (2) The LCD modules should be stored within the rated storage temperature range. The recommend condition is: Temperature: 0 ~ 35 °C at normal humidity.
- (3) The LCD modules should be stored in a room without acid, alkali or other harmful gas.

11.3 Transportation Precautions

The LCD modules should not be dropped or subject to violent mechanical shock during transportation. Also they should avoid excessive pressure, water, high humidity and direct sunlight.

11.4 Screen saver Precautions

Not display the fixed pattern for a long time. Use a screen saver, if the fixed pattern is displayed on the screen

11.5 Safety Precautions

- (1) When you waste damaged or unnecessary LCDs, it is recommended to crush LCDs into pieces and wash them off with solvents such as acetone and ethanol, which should later be burned
- (2) Be sure to turn off the power supply when inserting or disconnecting the LED backlight cable.
- (3) LED driver should be designed to limit or stop its function when over current is detected on the LED.