

Figure 31: Elstein FSR series

Elstein FSR panel radiators are ceramic infrared radiators, which are designed for operating temperatures up to 720 °C. Surface ratings of up to 64 kW/m² can be installed.

FSR series radiators are made using a full-pour casting ceramic process and are characterised by their concave design. Due to the design of this type, there is a space between the radiator and mounting plate, which reduces the heat absorbed by the wiring space.

FSR panel radiators can be used universally and are suitable for assembling radiation areas with any geometry required. They are available in three designs and cover the power range from 60 W to 1000 W.

With its FSR panel radiators, the company Elstein-Werk has been setting design, type, power and quality standards, recognised worldwide since 1952, for ceramic infrared panel radiators.

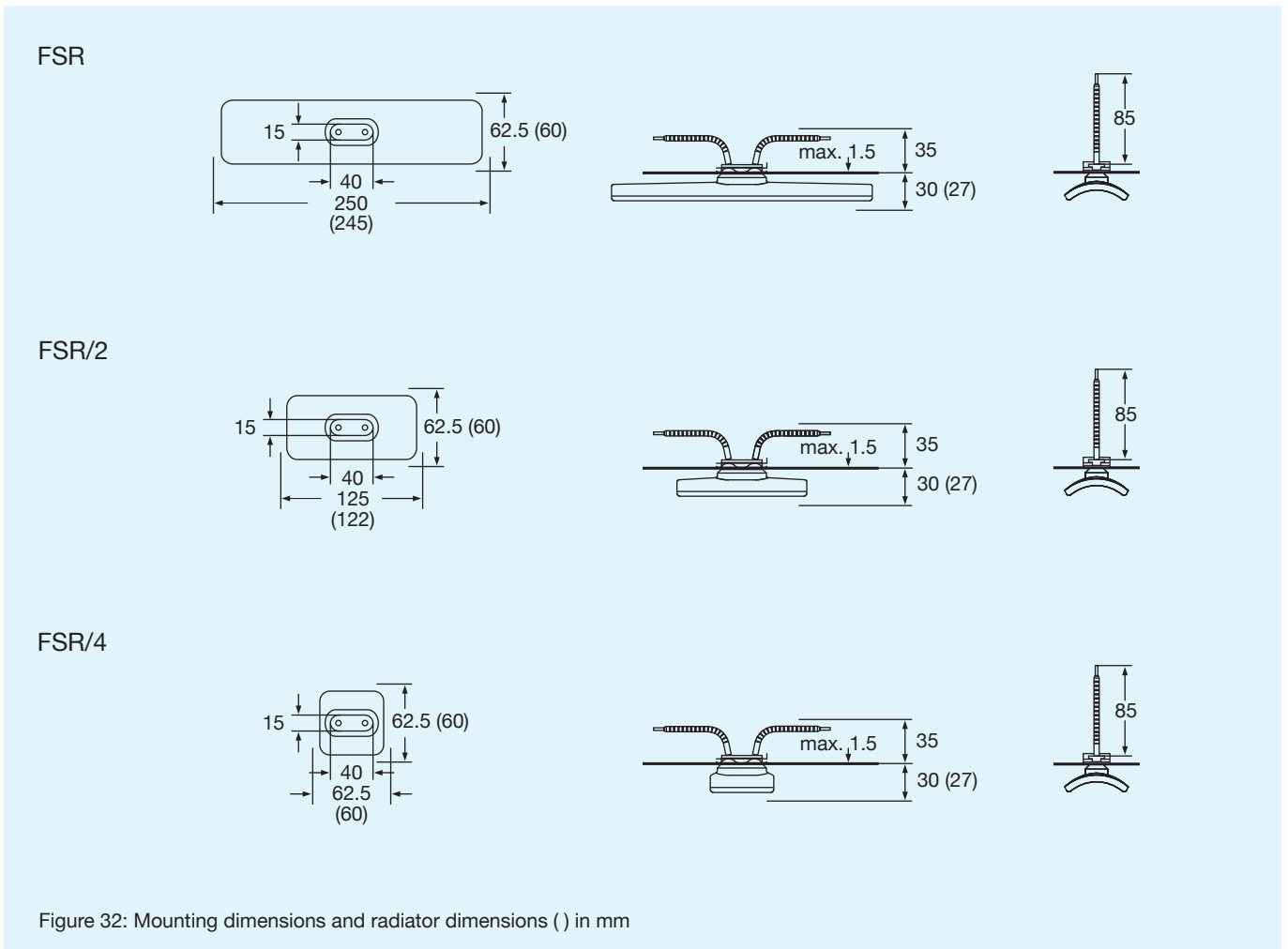
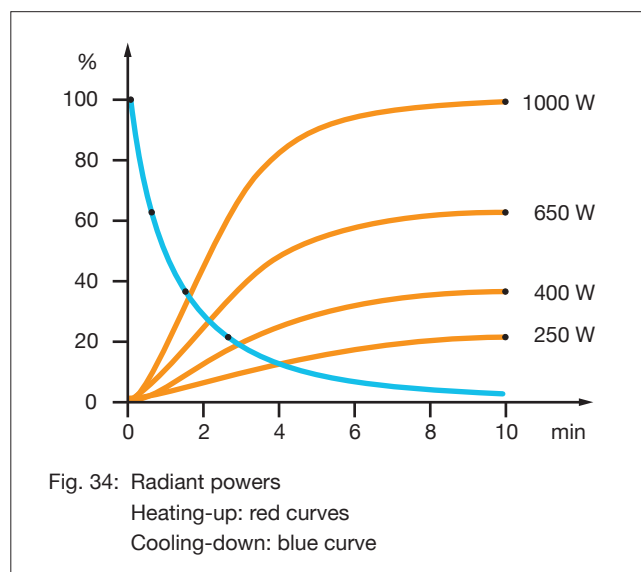
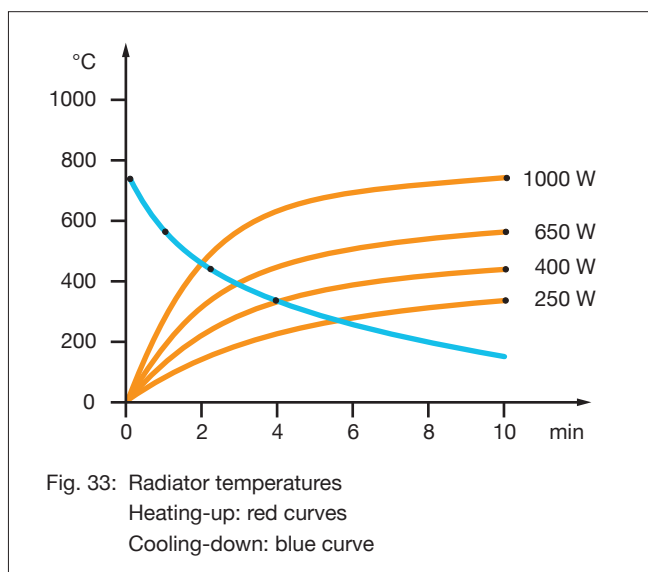
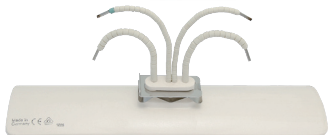

Figure 32: Mounting dimensions and radiator dimensions () in mm



Type, weight, wattage	FSR	220 g	250	400	650	1000	W
	FSR/2	125 g	125	200	325	500	W
	FSR/4	75 g	60	100	200	250	W
Surface rating			16.0	25.6	41.6	64.0	kW/m ²
Typical operating temperature			400	500	620	720	°C
Maximum permissible temperature			750	750	750	750	°C
Wavelength range			2 - 10				μm

<p>Standard design</p> <p>Operating voltage 230 V Ceramic full-pour casting Leads 85 mm Elstein standard socket Mounting set</p>	<p>Thermocouple radiators</p> <p>Designation T-FSR, T-FSR/2, T-FSR/4 Integrated thermocouple Type K (NiCr-Ni) TC leads 100 mm</p> 	<p>Variants</p> <p>Special wattages Special voltages Extended leads Leads with ring terminals</p>
---	--	--

The power can be controlled using thermocouple radiators together with TRD 1 temperature controllers, TSE thyristor switching units and other accessories.

IR radiation areas can be assembled using REO reflectors, REF construction sets, EBF construction elements and MBO mounting sheets.

The national safety regulations must be complied with for the respective application, for example, the IEC or EN standard 60519-1, Safety in electrical heating installations.

Further information and safety information are given in this document and in the mounting instruction enclosed with each radiator.