

TITLE:**DV430FHM-NN1 Final Product Specification**

BEIJING BOE DISPLAY TECHNOLOGY

Contents

No	ITEM	Page
	REVISIONS HISTORY	2
	CONTENTS	3
1	GENERAL DESCRIPTION	4
	1.1 Introduction	
	1.2 Features	
	1.3 Applications	
	1.4 General Specification	
2	ABSOLUTE MAXIMUM RATINGS	6
3	ELECTRICAL SPECIFICATIONS	7
	3.1 TFT LCD Module	
	3.2 LED Converter	
4	INTERFACE CONNECTION	9
	4.1 Module Input Signal & Power (1)	
	4.2 Module Input Signal & Power (2)	
	4.3 LED Converter Input Signal & Power	
5	SIGNAL TIMING SPECIFICATIONS	15
	5.1 Timing Parameters	
	5.2 Signal Timing Waveform	
	5.3 Input Signals, Basic Display Colors & Cray Scale Of Colors	
	5.4 Power Sequence	
6	OPTICAL SPECIFICATIONS	19
7	MECHANICAL CHARACTERISTICS	21
8	RELIABILITY	22
9	PRODUCT SERIAL NUMBER	23
10	PACKING INFORMATION	24
11	HANDING & CAUTIONS	26
12	APPENDIX	27

1.0 GENERAL DESCRIPTION

1.1 Introduction

DV430FHM-NN0 is a color active matrix TFT LCD MDL using amorphous silicon TFT's (Thin Film Transistors) as an active switching devices. This MDL has a 42.5 inch diagonally measured active area with FHD resolutions (1920 horizontal by 1080 vertical pixel array). Each pixel is divided into RED, GREEN, BLUE dots which are arranged in vertical stripe and this module can display 16.7M colors. The TFT-LCD panel is adapted for a low reflection and higher color type.

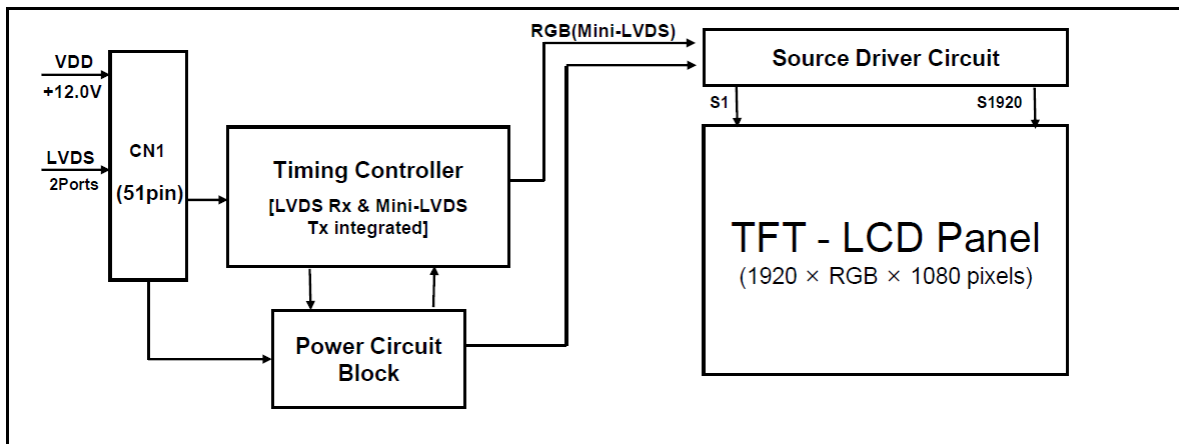

1.2 Features

- LVDS interface with 2 pixel / clock
- High-speed response
- Low color shift image quality
- 8-bit color depth, display 16.7M colors
- Narrow bezel and wide viewing angle, gate driver use GOA mode
- DE (Data Enable) only mode
- ADS technology is applied for high display quality
- RoHS compliant

1.3 Application

- Home Alone Multimedia TFT-LCD TV
- Display Terminals for Control System
- Ultra High Definition TV(UHD TV)
- AV application Products

1.4 General Specification

< Table 1. General Specifications >

Parameter	Specification	Unit	Remark
Active area	940.896(H) × 529.254(V)	mm	Array
Number of pixels	1920(H) × 1080(V)	pixels	
Pixel pitch	163.35(H) × 490.05(V)	μm	Array
Pixel arrangement	Pixels RGB Vertical stripe		Array
Display colors	16.7M (8bits True)	colors	
Display mode	Transmission mode, Normally Black		
Outline Dimension	961.7(H)x550.1(V) × 11.7(B)	mm	Mech
Weight	8.36(Typ)	Kg	Mech
Power Consumption	LED Driver:56.3W)	Watt	
Surface Treatment	Haze 1%,		

2.0 ABSOLUTE MAXIMUM RATINGS

The followings are maximum values which, if exceed, may cause faulty operation or damage to the unit. The operational and non-operational maximum voltage and current values are listed in Table 2.

< Table 2. LCD Module Electrical Specifications >

[VSS=GND=0V]

Parameter		Symbol	Min.	Max.	Unit	Remark
Power Supply Voltage	LCD Module	VDD	VSS-0.3	13.5	V	Ta = 25 °C
	Converter	VBL	VSS-0.3	26.4	V	
Operating Temperature		T _{OP}	0	+50	°C	Note 1
		T _{SUR}	-20	+60	°C	
Storage Temperature		T _{ST}	-20	+60	°C	
Operating Ambient Humidity		Hop	10	80	%RH	
Storage Humidity		Hst	10	80	%RH	

Note 1 : Temperature and relative humidity range are shown in the figure below.
Wet bulb temperature should be 39 °C max. and no condensation of water.

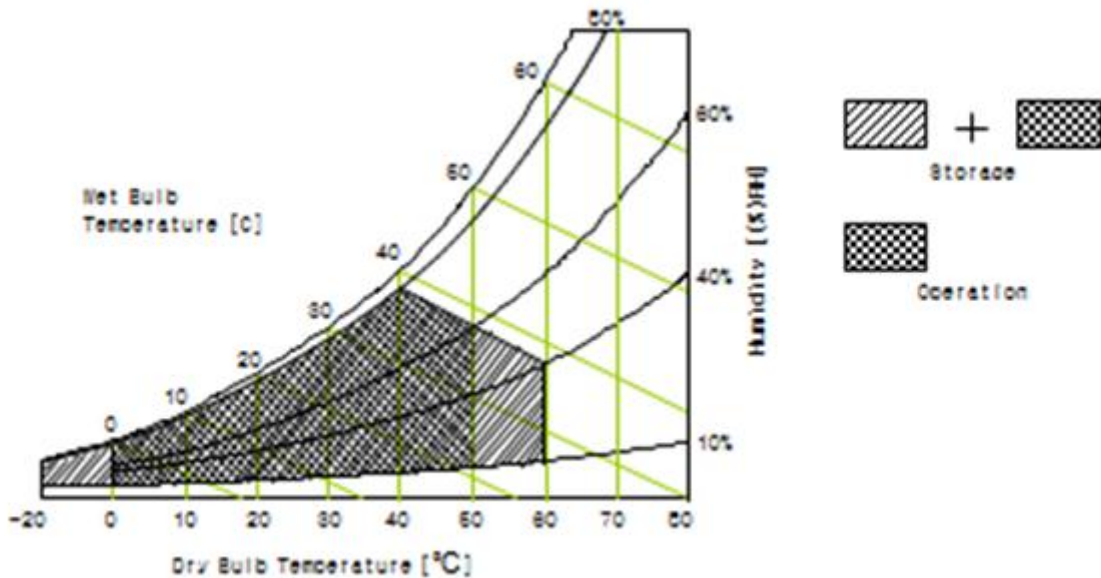

3.0 ELECTRICAL SPECIFICATIONS

3.1 TFT LCD Open Cell

< Table 3. Open Cell Electrical Specifications >

[Ta =25±2 °C]

Parameter		Symbol	Values			Unit	Remark
			Min	Typ	Max		
Power Supply Input Voltage		VDD	10.8	12	13.2	Vdc	
Power Supply Ripple Voltage		VRP			300	mV	
Power Supply Current		IDD	-	0.5	0.95	A	Note 1
Power Consumption		PDD		6	11.4	Watt	
Rush current		IRUSH	-	-	3.0	A	Note 2
V by One Interface	Differential Input High Threshold Voltage	VLVTH	+100		+300	mV	
	Differential Input Low Threshold Voltage	VLVTL	-300		-100	mV	
	Common Input Voltage	VLVC	1.0	1.2	1.4	V	
	Terminating Resistor	Rt	90	100	110	ohm	
CMOS Interface	Input High Threshold Voltage	VIH	2.7	-	3.3	V	
	Input Low Threshold Voltage	VIL	0	-	0.6	V	

Note 1 : The supply voltage is measured and specified at the interface connector of LCM.

The current draw and power consumption specified is for VDD=12.0V,

Frame rate fV=60Hz and Clock frequency = 74.25MHz.

Test Pattern of power supply current

a) Typ : Mosaic 7X5 (L0/L255)

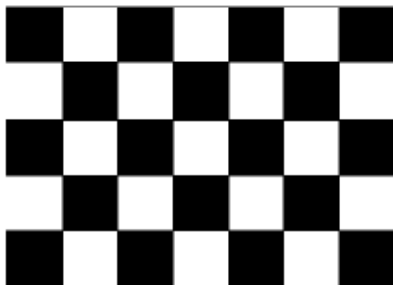

b) Max : Horizontal 1 Line (L0/L255)



c) Flicker Pattern

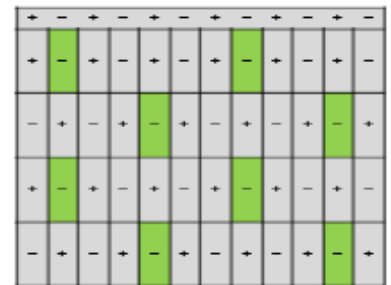

Note 2 : The duration of rush current is about 2ms and rising time of Power Input is 1ms(min)

3.2 LED Converter

< Table 4. LED Converter Electrical Specifications >

[Ta = 25 ± 2 °C]

Parameter	Symbol	Condition	Values			Unit	Note
			Min.	Typ.	Max.		
Input Voltage	VBL		23	24.0	25.2	V	
Input Current	IBL	V _{DIM} =3.3V		2.64		A	Note 1
Rush current	IRUSH	VBL= 24V		9.0		A	
Power Consumption	PBL	Typical Luminance		63.36		Watt	
B/L on/off control	V _{ON/OFF}	BL ON = High	2.8	3.3	5	V	
		BL OFF =Low	0	-	0.8	V	
Analog Dimming	V _{DIM}	Voltage	0		3.3	V	
	L _{DIM}	Luminance	20		100	%	
PWM Frequency	F _{PWM}		140	190	240	Hz	
PWM Level	High Level		2.8	3.3	5	V	
	Low Level		0	-	0.5	V	
PWM Duty	D _{PWM}		20	-	100	%	Note 2
Life Time			30k	-	-	Hrs	Note 3

Note 1: The specified current and power consumption are under the typical supply Input voltage, 24V. It is total power consumption.

Note 2 : High-duty = On/(On+Off) * 100

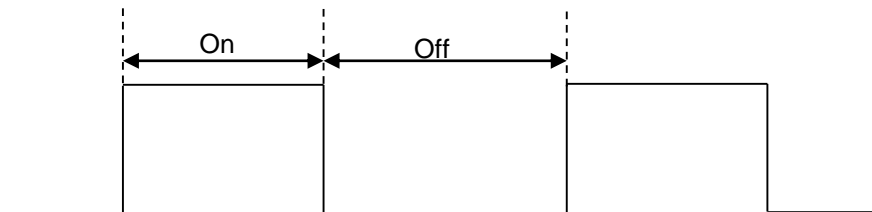

Note 3 : The life time of LED, 30,000Hrs, is determined as the time at which luminance of the LED is 50% compared to that of initial value at the typical LED current on condition of continuous operating at 25 ± 2°C.

4.0 INTERFACE CONNECTION

4.1 Open Cell Input Signal & Power

-LVDS Connector : PM.LVS.S040505101(UJC) or Equivalent.

< Table 5. Open Cell Input Connector Pin Configuration >

Pin No	Symbol	Description	Pin No	Symbol	Description
1	NC	No connection	21	GND	Ground
2	SDA	I ² C Data	22	CH1[3]-	First pixel negative LVDS differential data input. Pair3
3	SCL	I ² C Clock	23	CH1[3]+	First pixel positive LVDS differential data input. Pair3
4	NC	Not Connected	24	NC	No connection
5	NC	Not Connected	25	NC	No connection
6	NC	Not Connected	26	NC	No connection
7	SELLVDS	High: JEIDA Low or Open: VESA	27	NC	No connection
8	NC	Not Connected	28	CH2[0]-	Second pixel negative LVDS differential data input. Pair0
9	NC	Not Connected	29	CH2[0]+	Second pixel positive LVDS differential data input. Pair0
10	NC	Not Connected	30	CH2[1]-	Second pixel negative LVDS differential data input. Pair1
11	GND	Ground	31	CH2[1]+	Second pixel positive LVDS differential data input. Pair1
12	CH1[0]-	First pixel negative LVDS differential data input. Pair0	32	CH2[2]-	Second pixel negative LVDS differential data input. Pair2
13	CH1[0]+	First pixel positive LVDS differential data input. Pair0	33	CH2[2]+	Second pixel positive LVDS differential data input. Pair2
14	CH1[1]-	First pixel negative LVDS differential data input. Pair1	34	GND	Ground
15	CH1[1]+	First pixel positive LVDS differential data input. Pair1	35	CH2CLK-	Second pixel negative LVDS clock
16	CH1[2]-	First pixel negative LVDS differential data input. Pair2	36	CH2CLK+	Second pixel positive LVDS clock
17	CH1[2]+	First pixel positive LVDS differential data input. Pair2	37	GND	Ground
18	GND	Ground	38	CH2[3]-	Second pixel negative LVDS differential data input. Pair3
19	CH1CLK-	First pixel negative LVDS clock	39	CH2[3]+	Second pixel positive LVDS differential data input. Pair3
20	CH1CLK+	First pixel positive LVDS clock			

Pin No	Symbol	Description	Pin No	Symbol	Description
40	NC	Not Connected	46	GND	Ground
41	NC	Not Connected	47	NC	Not Connected
42	NC	Not Connected	48	VCC	Input Voltage +12V
43	NC	Not Connected	49	VCC	Input Voltage +12V
44	GND	Ground	50	VCC	Input Voltage +12V
45	GND	Ground	51	VCC	Input Voltage +12V

Notes : Notes : 1. NC(Not Connected) : This pins are only used for BOE internal operations.

2.Input Level of LVDS signal is based on the EIA-644 Standard.

3. LVDS_SEL: This pin is used for selecting LVDS signal data format.

If this Pin : High (3.3V) JEIDA LVDS format

Otherwise : Low(GND) or Open (NC) Normal NS LVDS format

Rear view of LCM

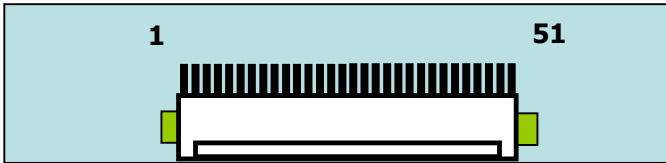

BIST Pattern

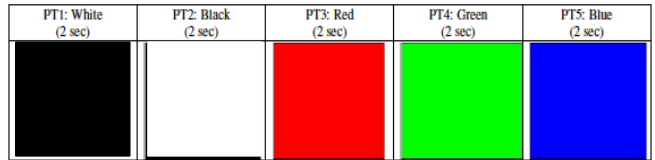

4.2 LED Converter Input Signal & Power

- Connector : CI0114M1HRL-NH (Cvilux) or equivalent

< Table 6. LED Converter Input Connector Pin Configuration >

CN1-14PIN-2.0

Pin No	Symbol	Description	
1	VBL	Power Supply +24V	
2	VBL	Power Supply +24V	
3	VBL	Power Supply +24V	
4	VBL	Power Supply +24V	
5	VBL	Power Supply +24V	
6	GND	Ground	
7	GND	Ground	
8	GND	Ground	
9	GND	Ground	
10	GND	Ground	
11	NC	No Connection	
12	VBLON/OFF	BLU On-Off control	Max : 3.3V / Min : 0V
13	PWM 调光	0V:Min, 3.3V:Max	On : 2.8V~5.0V/Off :0~0.8V
14	NC	NC	

Notice: 1. PIN 13:External PWM Control .

2. While system is turned ON or OFF, the power sequences must follow as below descriptions:

Turn ON sequence: VBL-ON → PWM signal → BLON

Turn OFF sequence: BLOFF → PWM signal → VBL-ON

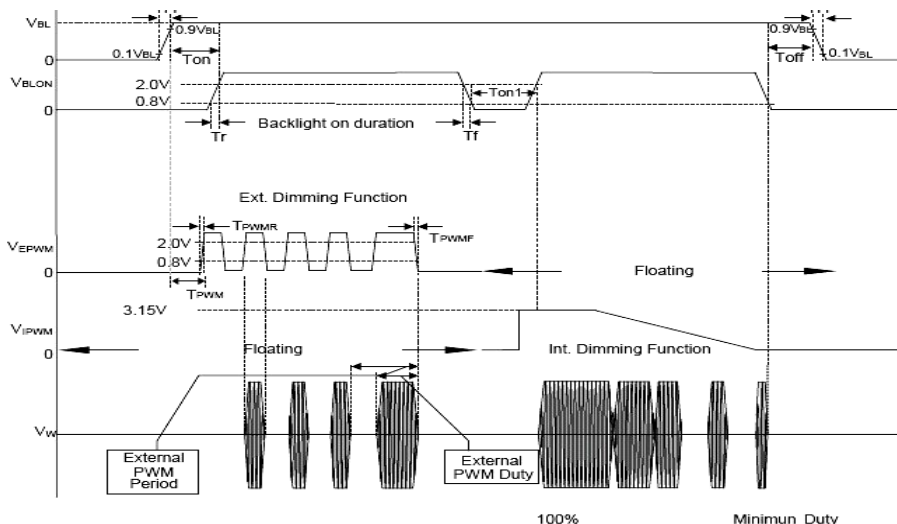

4.3 LVDS Interface

-LVDS Receiver : Timing Controller (LVDS Rx merged) / LVDS Data : Pixel Data

< Table 7. Open Cell Input Connector Pin Configuration >

Item	Symbol	Min	Typ	Max	Unit	Remark
CLKIN Period	tRCIP	10.31	13.47(10.78)	15.87	nsec	
Input Data 0	tRIP1	-0.42	0.0	+0.42	nsec	
Input Data 1	tRIP0	tRCIP/7-0.42	tRCIP/7	tRCIP/7+0.42	nsec	
Input Data 2	tRIP6	2 × tRCIP/7-0.42	2 × tRCIP/7	2 × tRCIP/7+0.42	nsec	
Input Data 3	tRIP5	3 × tRCIP/7-0.42	3 × tRCIP/7	3 × tRCIP/7+0.42	nsec	
Input Data 4	tRIP4	4 × tRCIP/7-0.42	4 × tRCIP/7	4 × tRCIP/7+0.42	nsec	
Input Data 5	tRIP3	5 × tRCIP/7-0.42	5 × tRCIP/7	5 × tRCIP/7+0.42	nsec	
Input Data 6	tRIP2	6 × tRCIP/7-0.42	6 × tRCIP/7	6 × tRCIP/7+0.42	nsec	

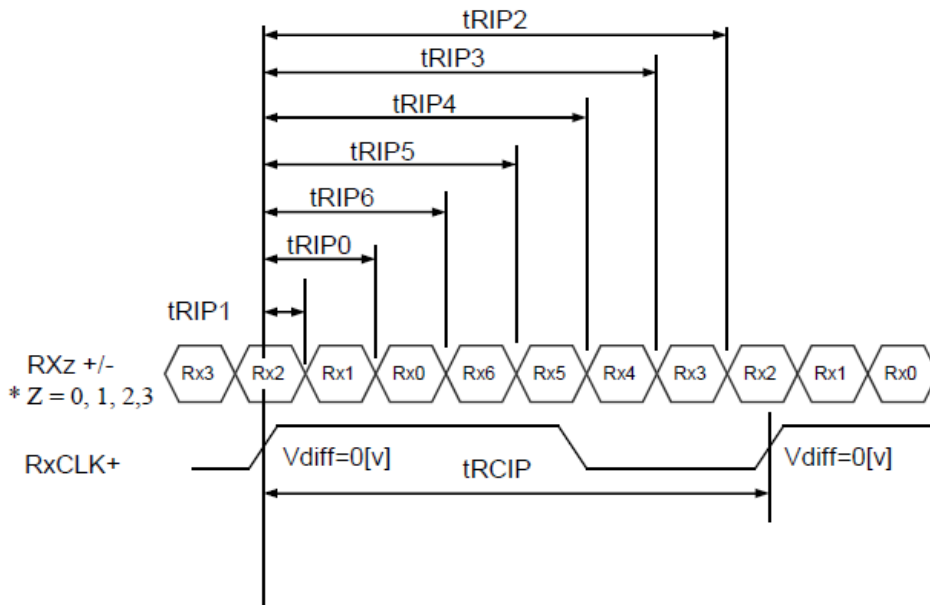

* Vdiff = (RXz+)-(RXz-),.... ,(RXCLK+)-(RXCLK-)

4.4 LVDS Rx Interface Eye Diagram

< Table 8. LVDS Rx Interface Eye Diagram >

Symbol	Min	Typ	Max	Unit	Note
A	—	100	—	mV	
B	—	100	—	mV	
C	—	0	—	mV	
D	—	-100	—	mV	
E	—	-100	—	mV	
F	—	0	—	mV	

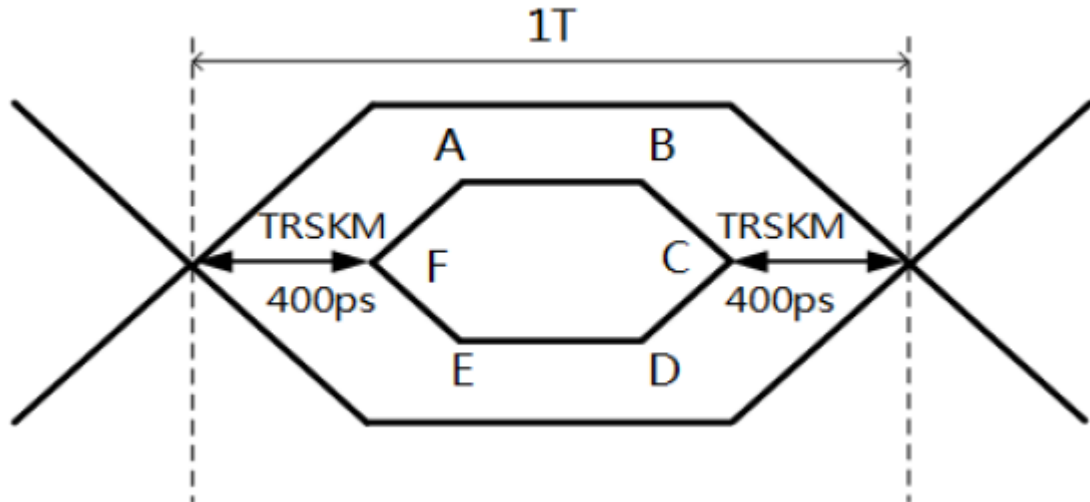

Notes:

1. Time F to A, B to C, C to D, E to F is 150p second.
2. LVDS clock=85Mhz.
3. The time A to B= $1T - 2 * TRSKM - 2 * 150ps$.

4.5 LVDS Receiver Differential Input

< Table 9. LVDS Receiver Differential Input >

Symbol	Parameter	Min	Typ	Max	Unit	Condition
R_{xvth}	Differential input high threshold voltage			+0.1V	V	$R_{xvcm} = 1.2V$
R_{xvtl}	Differential input low threshold voltage	-0.1V			V	
R_{xvin}	Input voltage range (singled-end)	0		2.4	V	
R_{xvcm}	Differential input common mode voltage	$ V_{ID} /2$		$2.4 - V_{ID} /2$	V	
$ V_{ID} $	Differential input voltage	0.1		0.6	V	

Single-end Signals

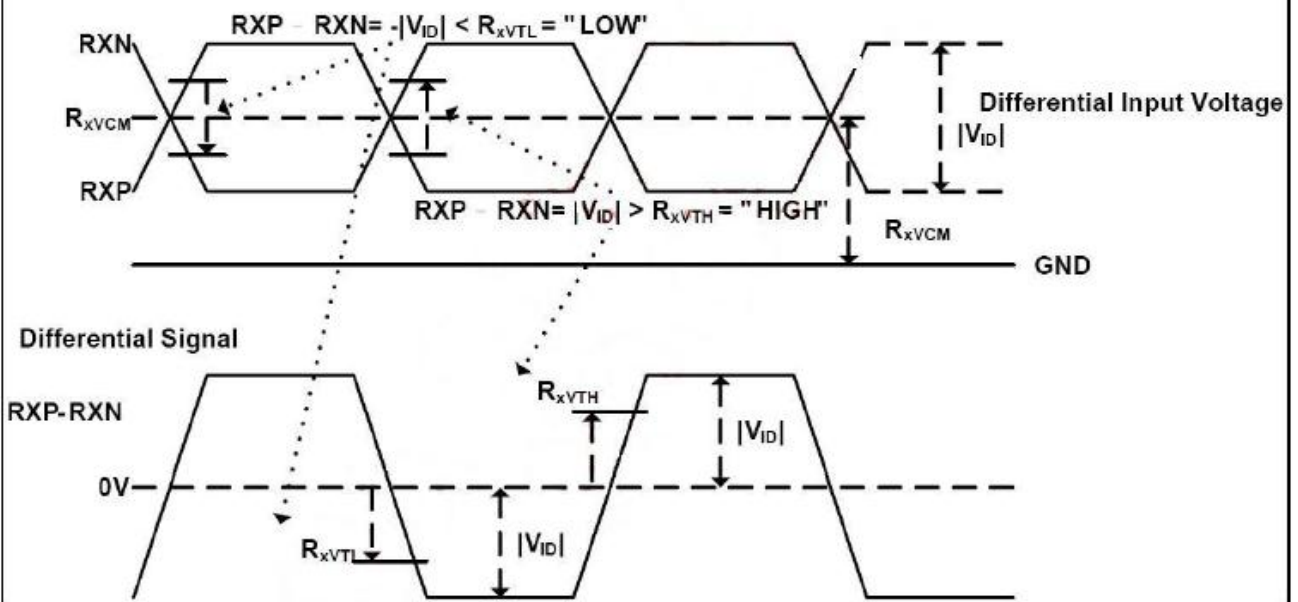

5.0 SIGNAL TIMING SPECIFICATION

5.1 Timing Parameters (DE only mode)

< Table 10. Timing Table >

Item		Symbols	Min	Typ	Max	Unit	
Clock	Frequency	1/Tc	60	74.25	78	MHz	
	High Time	Tch	-	4/7Tc	-		
	Low Time	Tcl	-	4/7Tc	-		
Frame Period		Tv	1100	1125	1149	lines	
			48.5	60	63	Hz	
Horizontal Active Display Term		Valid	t _{HV}	-	960	-	t _{CLK}
		Total	t _{HP}	1060	1100	1200	t _{CLK}
Vertical Active Display Term		Valid	t _{VV}	-	1080	-	t _{HP}
		Total	t _{VP}	1100	1125	1149	t _{HP}

Notes: This product is DE only mode. The input of Hsync & Vsync signal does not have an effect on normal operation.

< Table 11. LVDS Input SSCG >

Symbol	Parameter	Condition	Min	Typ	Max	Unit
F	LVDS Input frequency	-	60	74.25	78	MHz
T _{LVSK}	LVDS channel to channel skew	F=100MHz V _{IC} =1.2V V _{ID} =±400mV	-380	-	+380	ps
F _{LVMOD}	Modulating frequency of input clock during SSC		60	-	85	KHz
F _{LVDEV}	Maximum deviation of input clock frequency during SSC		-3	-	+3	%
T _{CY-CY}	Cycle to Cycle jitter		-	-	100	ps

5.2 Signal Timing Waveform

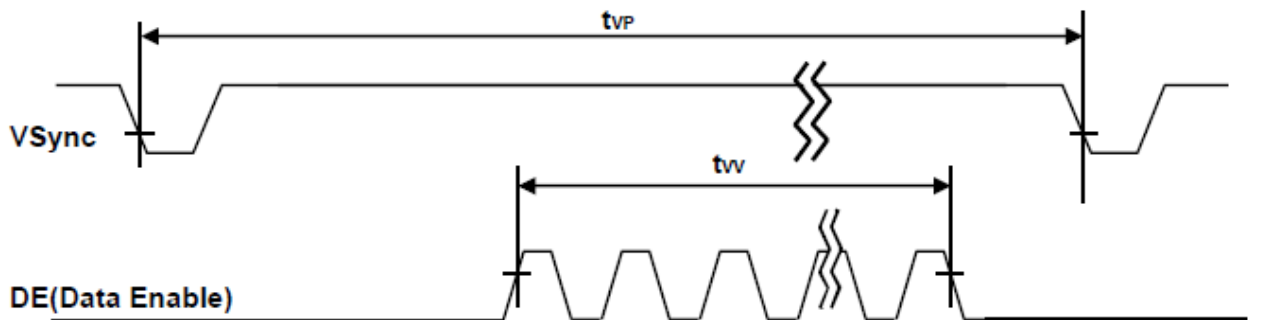
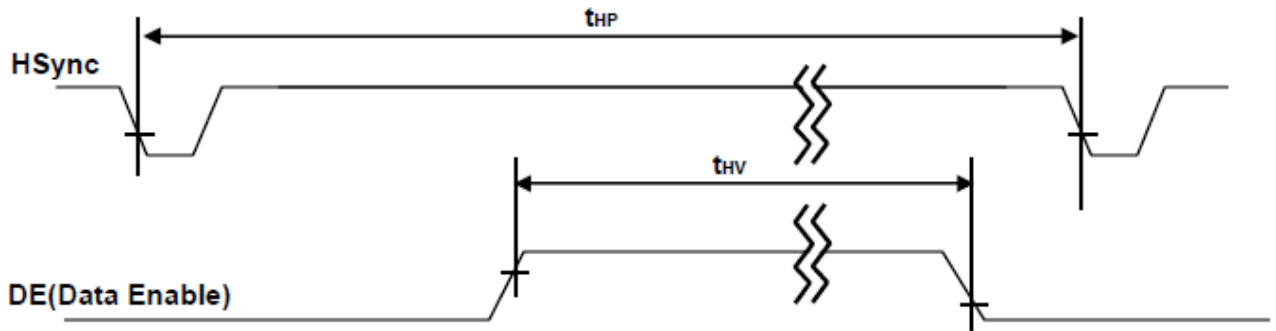
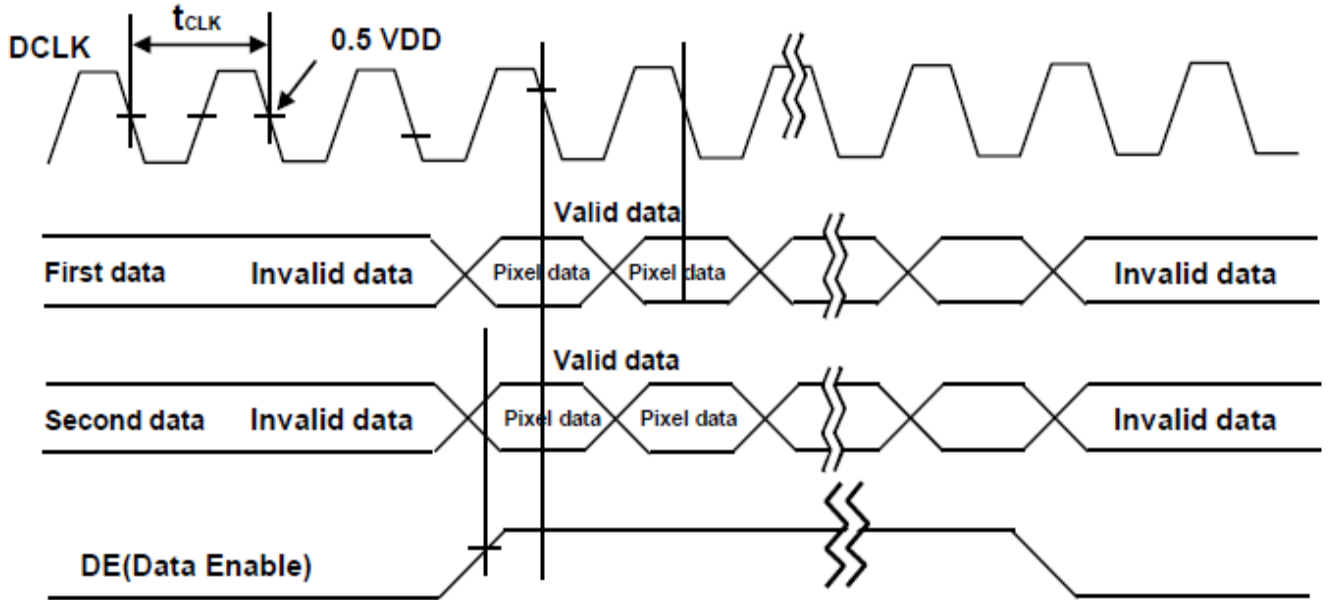

5.3 Input Signals, Basic Display Colors and Gray Scale of Colors

< Table 12. Input Signal and Display Color Table >

Color & Gray Scale		Input Data Signal																							
		Red Data								Green Data								Blue Data							
		R7	R8	R5	R4	R3	R2	R1	R0	G7	G8	G5	G4	G3	G2	G1	G0	B7	B8	B5	B4	B3	B2	B1	B0
Basic Colors	Black	0	0	0	0	0	0	0	0	0	0	0	0	0	0	0	0	0	0	0	0	0	0	0	
	Blue	0	0	0	0	0	0	0	0	0	0	0	0	0	0	0	0	1	1	1	1	1	1	1	
	Green	0	0	0	0	0	0	0	1	1	1	1	1	1	1	1	0	0	0	0	0	0	0		
	Cyan	0	0	0	0	0	0	0	1	1	1	1	1	1	1	1	1	1	1	1	1	1	1		
	Red	1	1	1	1	1	1	1	0	0	0	0	0	0	0	0	0	0	0	0	0	0	0		
	Magenta	1	1	1	1	1	1	1	0	0	0	0	0	0	0	0	1	1	1	1	1	1	1		
	Yellow	1	1	1	1	1	1	1	1	1	1	1	1	1	1	1	0	0	0	0	0	0	0		
	White	1	1	1	1	1	1	1	1	1	1	1	1	1	1	1	1	1	1	1	1	1	1		
Gray Scale of Red	Black	0	0	0	0	0	0	0	0	0	0	0	0	0	0	0	0	0	0	0	0	0	0		
	△	0	0	0	0	0	0	1	0	0	0	0	0	0	0	0	0	0	0	0	0	0	0		
	Darker	0	0	0	0	0	0	1	0	0	0	0	0	0	0	0	0	0	0	0	0	0	0		
	△																								
	▽																								
	Brighter	1	1	1	1	1	1	0	1	0	0	0	0	0	0	0	0	0	0	0	0	0	0		
	▽	1	1	1	1	1	1	1	0	0	0	0	0	0	0	0	0	0	0	0	0	0	0		
	Red	1	1	1	1	1	1	1	0	0	0	0	0	0	0	0	0	0	0	0	0	0	0		
Gray Scale of Green	Black	0	0	0	0	0	0	0	0	0	0	0	0	0	0	0	0	0	0	0	0	0	0		
	△	0	0	0	0	0	0	0	0	0	0	0	0	0	0	1	0	0	0	0	0	0	0		
	Darker	0	0	0	0	0	0	0	0	0	0	0	0	0	1	0	0	0	0	0	0	0	0		
	△																								
	▽																								
	Brighter	0	0	0	0	0	0	0	1	1	1	1	1	1	0	1	0	0	0	0	0	0	0		
	▽	0	0	0	0	0	0	0	1	1	1	1	1	1	1	0	0	0	0	0	0	0	0		
	Green	0	0	0	0	0	0	0	1	1	1	1	1	1	1	1	0	0	0	0	0	0	0		
Gray Scale of Blue	Black	0	0	0	0	0	0	0	0	0	0	0	0	0	0	0	0	0	0	0	0	0	0		
	△	0	0	0	0	0	0	0	0	0	0	0	0	0	0	0	0	0	0	0	0	0	1		
	Darker	0	0	0	0	0	0	0	0	0	0	0	0	0	0	0	0	0	0	0	0	0	1		
	△																								
	▽																								
	Brighter	0	0	0	0	0	0	0	0	0	0	0	0	0	0	0	1	1	1	1	1	1	0		
	▽	0	0	0	0	0	0	0	0	0	0	0	0	0	0	0	1	1	1	1	1	1	0		
	Blue	0	0	0	0	0	0	0	0	0	0	0	0	0	0	0	1	1	1	1	1	1	1		
Gray Scale of White	Black	0	0	0	0	0	0	0	0	0	0	0	0	0	0	0	0	0	0	0	0	0	0		
	△	0	0	0	0	0	0	1	0	0	0	0	0	0	0	1	0	0	0	0	0	0	1		
	Darker	0	0	0	0	0	0	1	0	0	0	0	0	0	1	0	0	0	0	0	0	0	1		
	△																								
	▽																								
	Brighter	1	1	1	1	1	1	0	1	1	1	1	1	1	0	1	1	1	1	1	1	1	0		
	▽	1	1	1	1	1	1	1	0	1	1	1	1	1	1	0	1	1	1	1	1	1	0		
	White	1	1	1	1	1	1	1	1	1	1	1	1	1	1	1	1	1	1	1	1	1	1		

5.4 Power Sequence

To prevent a latch-up or DC operation of the Open Cell, the power on/off sequence shall be as shown in below

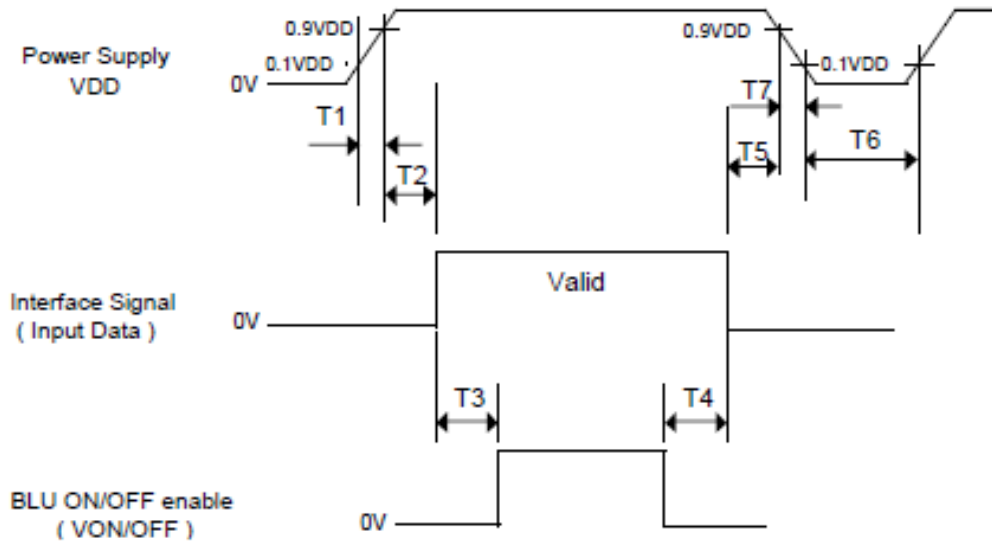

< Table 13. Sequence Table >

Parameter	Values			Units
	Min	Typ	Max	
T1	0.5	-	20	ms
T2	10	-	100	ms
T3	200	-	-	ms
T4	200	-	-	ms
T5	0	-	-	ms
T6	1	-	-	s

- Notes:
1. Back Light must be turn on after power for logic and interface signal are valid.
 2. Even though T1 is out of SPEC, it is still ok if the inrush current of VDD is below the limit.
 3. When $VDD < 0.9VDD$ (Typ.), Power off.
 4. T7 decreases smoothly, if there were rebounding voltage, it must smaller than 5 volts.

6.0 OPTICAL SPECIFICATIONS

The test of optical specifications shall be measured in a dark room (ambient luminance 1 lux and temperature = 25 ± 2 °C) with the equipment of Luminance meter system (Goniometer system and PR730) and test unit shall be located at an approximate distance 180cm from the LCD surface at a viewing angle of θ and ϕ equal to 0°. We refer to $\theta = 0^\circ (= \theta_3)$ as the 3 o'clock direction (the "right"), $\theta = 90^\circ (= \theta_{12})$ as the 12 o'clock direction ("upward"), $\theta = 180^\circ (= \theta_9)$ as the 9 o'clock direction ("left") and $\theta = 270^\circ (= \theta_6)$ as the 6 o'clock direction ("bottom"). While scanning θ and/or ϕ , the center of the measuring spot on the Display surface shall stay fixed. The measurement shall be executed after 30 minutes warm-up period. VDD shall be 12.0V at 25 °C. Optimum viewing angle direction is 6 o'clock.

< Table 14. Optical Table >

[VDD = 12.0V, Frame rate = 60Hz, Ta = 25 ± 2 °C]

Parameter		Symbol	Condition	Min	Typ	Max	Unit	Remark	
Viewing Angle	Horizontal	θ_3	CR > 10		89		Deg.	Note 1	
		θ_9			89		Deg.		
	Vertical	θ_{12}			89		Deg.		
		θ_6			89		Deg.		
Color Temperature				9000	10,000	11,500	K		
Color Gamut				70	72	-	%		
Contrast ratio		CR		800:1	1200:1	-		Note 2	
Luminance of White		Y_w			400	-	cd/m ²	Note 3	
White luminance uniformity		ΔY			70	75		%	Note 4
Reproduction of color	White	W_x		$\theta = 0^\circ$ (Center) Normal Viewing Angle	TYP. - 0.03	0.280	TYP. + 0.03		Note 5
		W_y	0.290						
	Red	R_x	0.640						
		R_y	0.334						
	Green	G_x	0.296						
		G_y	0.607						
	Blue	B_x	0.149						
		B_y	0.069						
Response Time	G to G	T_g		-	8	10	ms	Note 6	
Gamma Scale				2.0	2.2	2.4			

Note :

1. Viewing angle is the angle at which the contrast ratio is greater than 10. The viewing angles are determined for the horizontal or 3, 9 o'clock direction and the vertical or 6, 12 o'clock direction with respect to the optical axis which is normal to the LCD surface.
2. Contrast measurements shall be made at viewing angle of $\theta = 0^\circ$ and at the center of the LCD surface. Luminance shall be measured with all pixels in the view field set first to white, then to the dark (black) state. (See Figure 1 shown in Appendix) Luminance Contrast Ratio (CR) is defined mathematically.

$$CR = \frac{\text{Luminance when displaying a white raster}}{\text{Luminance when displaying a black raster}}$$

3. The color chromaticity coordinates specified in Table 9 shall be calculated from the spectral data measured with all pixels first in red, green, blue and white. Measurements shall be made at the center of the panel. The BLU is used by BOE.
4. Response time T_g is the average time required for display transition by switching the input signal as below table and is based on Frame rate $f_V = 60\text{Hz}$ to optimize. Each time in below table is defined as Figure 2 and shall be measured by switching the

Measured Response Time	Target																
	0	15	31	47	63	79	95	111	127	143	159	175	191	207	223	239	255
Start	0																
	15																
	31																
	47																
	63																
	79																
	95																
	111																
	127																
	143																
	159																
	175																
	191																
	207																
	223																
	239																
	255																

5. Definition of Transmittance (T%) :
Module is with white(L255) signal input

$$\text{Transmittance} = \frac{\text{Luminance of LCD Module}}{\text{Luminance of BLU}} \times 100 \%$$

7.0 MECHANICAL CHARACTERISTICS

7.1 Dimensional Requirements

Figure 4 (located in Appendix) shows mechanical outlines for the model DV430FHM-NN0. Other parameters are shown in Table 15.

< Table 15. Dimensional Parameters >

Parameter	Specification	Unit
Dimensional outline	961.7(H)x550.0(V)× 11.7(B)	mm
Weight	8.36	Kg
Active area	940.896(H) × 529.254(V)	mm
Pixel pitch	163.35(H) × 490.05(V)	mm
Number of pixels	1920(H) × 1080(V) (1 pixel = R + G + B dots)	pixels
Back-light	E-LED Backlight	

7.2 Mounting

See Figure 5. (Shown in Appendix)

7.3 Anti-Glare and Polarizer Hardness

The surface of the LCD has an low haze coating to reduce scratching. Front Polarizer hardness is at less 3H.

8.0 RELIABILITY TEST

The Reliability test items and its conditions are shown in below.

< Table 16. Reliability Test Parameters >

No	Test Items	Conditions
1	High temperature storage test	Ta = 60 °C, 240 hrs
2	Low temperature storage test	Ta = -20 °C, 240 hrs
3	High temperature & high humidity operation test	Ta = 50 °C, 80%RH, 240hrs
4	High temperature operation test	Ta = 50 °C, 240hrs
5	Low temperature operation test	Ta = -5 °C, 240hrs
6	Thermal shock	Ta = -20 °C ↔ 60 °C (0.5 hr), 100 cycle
7	Vibration test (non-operating)	Frequency : 10 ~ 300 Hz, Random Gravity / AMP : 1.0 Grms Period : X, Y, Z 30 min/axis
8	Shock test (non-operating)	Gravity : 50G Pulse width : 11msec, Sine wave ± X, ± Y, ± Z Once for each direction
9	Electro-static discharge test	Air : ± 15kV , 150pF/330Ω , 100Point , 1time/Point Contact : ± 8kV , 150pF/330Ω , 100Point , 1time/Point Non operation Contact: ± 4KV~ ± 6KV, 150pF/330Ω, 100Point, Input connector Pin, 3 times/pin with no function loss

9.0 PRODCUT SERIAL NUMBER

XXXX
XXXXXX ④

XXXXXXXX-XXX ①

B10

Module ID 条形码

XXXX ⑤

XXXXXXXXXXXXXXXXXXXX ②

PP ID 条形码

XX-XXXXXX-XXXXX-XXX-XXXX ③

MADE IN CHINA

Module ID编码原则

打印内容，说明如下:

- ① FG-CODE
- ② Module ID，最后一位为Revision Code（扫描不显示），前17位编码规则如下
- ③ PPID（客户端ID）
- ④ D/PN码
- ⑤ 生产年份+生产周别（中间无空格）

Digit	1	2	3	4	5	6	7	8	9	10	11	12	13	14	15	16	17
Code	S	L	S	A	1	0	8	5	9	4	2	0	0	0	1	D	B
Description	Product Code/GBN → FG-CODE— —对应		Grade	line	Year	Month	Model Extension Code (Last 4 Digits of FG-CODE)				Serial No. Hex-Decimal 000000-FFFFFF						

10.0 PACKING INFORMATION

BOE provides the standard shipping container for customers, unless customer specifies their packing information. The standard packing method and Barcode information are shown in below

10.1 Packing Order

Put inner EPS-lower on the pallet

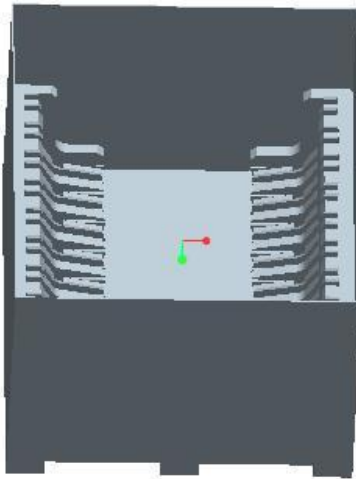

Put 20pcs MDL inside the BOX

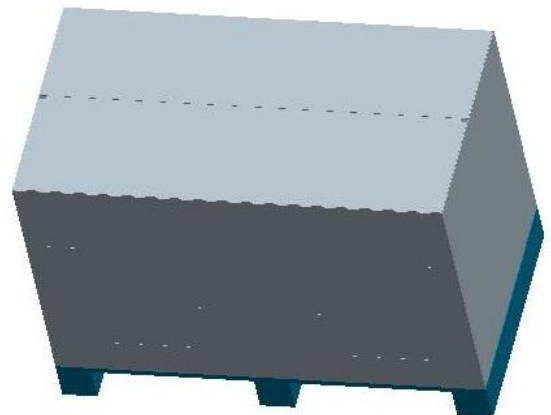
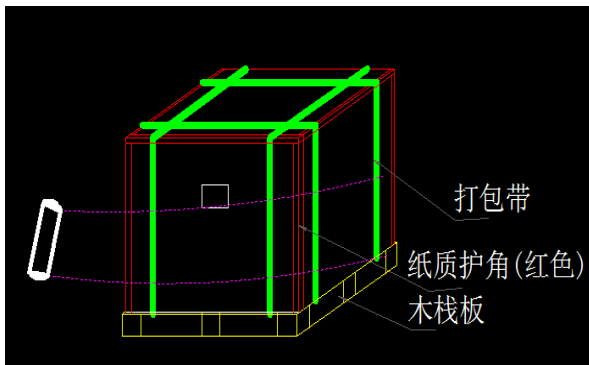

Seal the box and stick label to the assigned area

Put the other EPS-box on the first

10.2 Packing Note

- Box Dimension : 1140mm (L) × 1070mm (W) × 640mm (H)
- Package Quantity in one Box : 20pcs

10.3 Box Label

- Label Size : 100 mm (L) × 50 mm (W)
- Contents

Model : DV430FHM-NN1

Q`ty : 20 Module in one box.

Serial No. : Box Serial No. See next page for detail description.

Date : Packing Date

FG Code : FG Code of Product

BOE FUZHOU JINGDONGFANG OPTOELECTRONICS TECHNOLOGY Co.,LTD

MODEL:	DV430FHM-NN1 ①	Q`TY:	20	②
SERIAL NO.:	XXXXXXXXXXXXX ③	DATE:	XXXX.XX.XX	④

Box ID 条形码

XXXX ⑤

➤ 打印标识, 说明如下:

1. FG-CODE
2. 产品数量
3. Box ID, 编码规则如下
4. Box Packing 日期
5. FG-CODE 后四位

BOX ID编码原则

Digit	1	2	3	4	5	6	7	8	9	10	11	12	13
Code	S	L	S	A	1	6	3	D	0	0	1	A	1
Description	Products GBN		Grade	Line	Year		Month	Revision Code	Serial No.				

11.0 HANDLING & CAUTIONS

- (1) Cautions when taking out the module
 - Pick the pouch only, when taking out module from a shipping package.
- (2) Cautions for handling the module
 - As the electrostatic discharges may break the LCD module, handle the LCD module with care. Peel a protection sheet off from the LCD panel surface as slowly as possible.
 - As the LCD panel and back - light element are made from fragile glass material, impulse and pressure to the LCD module should be avoided.
 - As the surface of the polarizer is very soft and easily scratched, use a soft dry cloth without chemicals for cleaning.
 - Do not pull the interface connector in or out while the LCD module is operating.
 - Put the module display side down on a flat horizontal plane.
 - Handle connectors and cables with care.
- (3) Cautions for the operation
 - When the module is operating, do not lose CLK, ENAB signals. If any one of these signals is lost, the LCD panel would be damaged.
 - Obey the supply voltage sequence. If wrong sequence is applied, the module would be damaged.
- (4) Cautions for the atmosphere
 - Dew drop atmosphere should be avoided.
 - Do not store and/or operate the LCD module in a high temperature and/or humidity atmosphere. Storage in an electro-conductive polymer packing pouch and under relatively low temperature atmosphere is recommended.
- (5) Cautions for the module characteristics
 - Do not apply fixed pattern data signal to the LCD module at product aging.
 - Applying fixed pattern for a long time may cause image sticking.
- (6) Other cautions
 - Do not disassemble and/or re-assemble LCD module.
 - Do not re-adjust variable resistor or switch etc.
 - When returning the module for repair or etc., Please pack the module not to be broken. We recommend to use the original shipping packages.

12.0 APPENDIX

< Figure 1. Measurement Set Up >

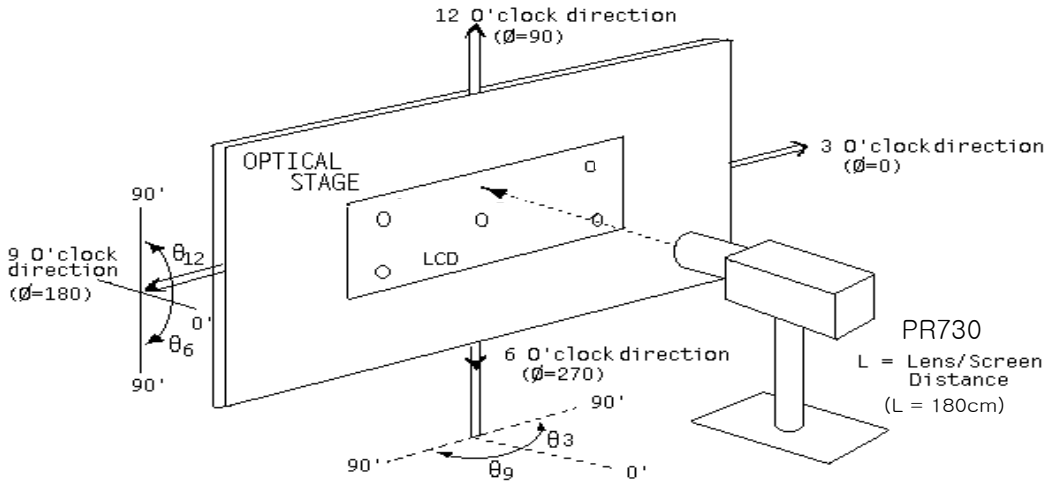

< Figure 2. White Luminance and Uniformity Measurement Locations >

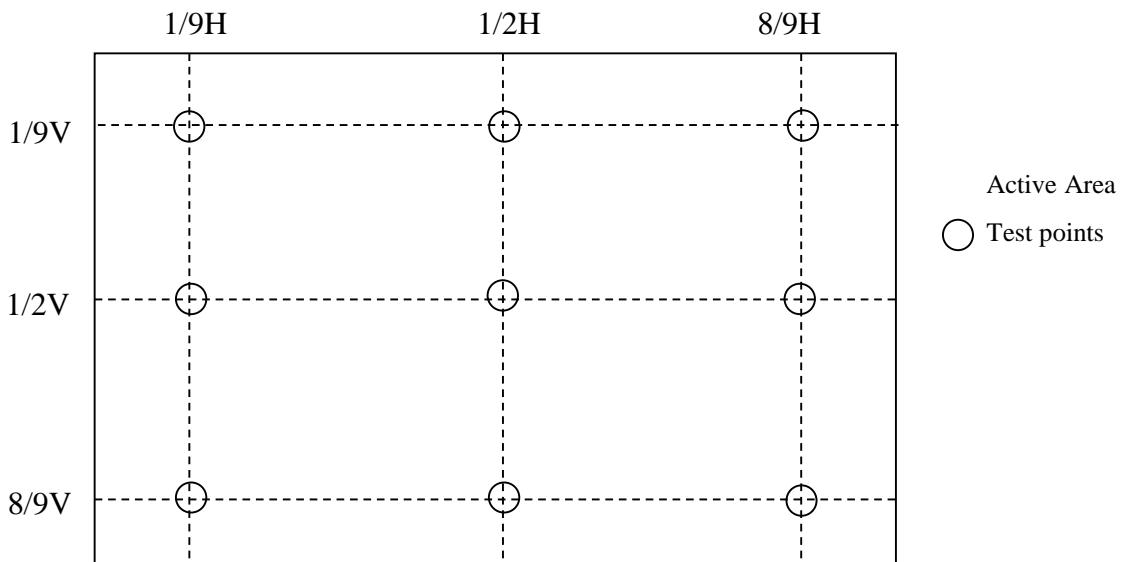

< Figure 3. Response Time Testing >

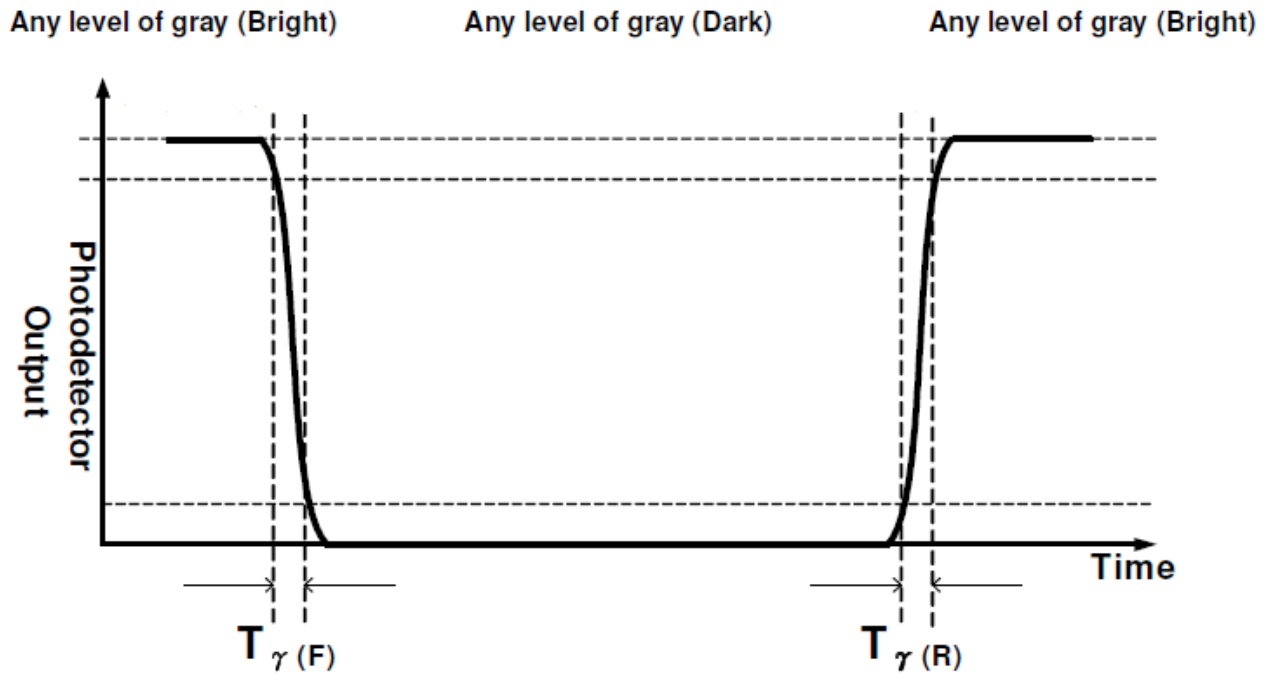

< Figure 4. TFT-LCD Module Outline Dimensions (Front View) >

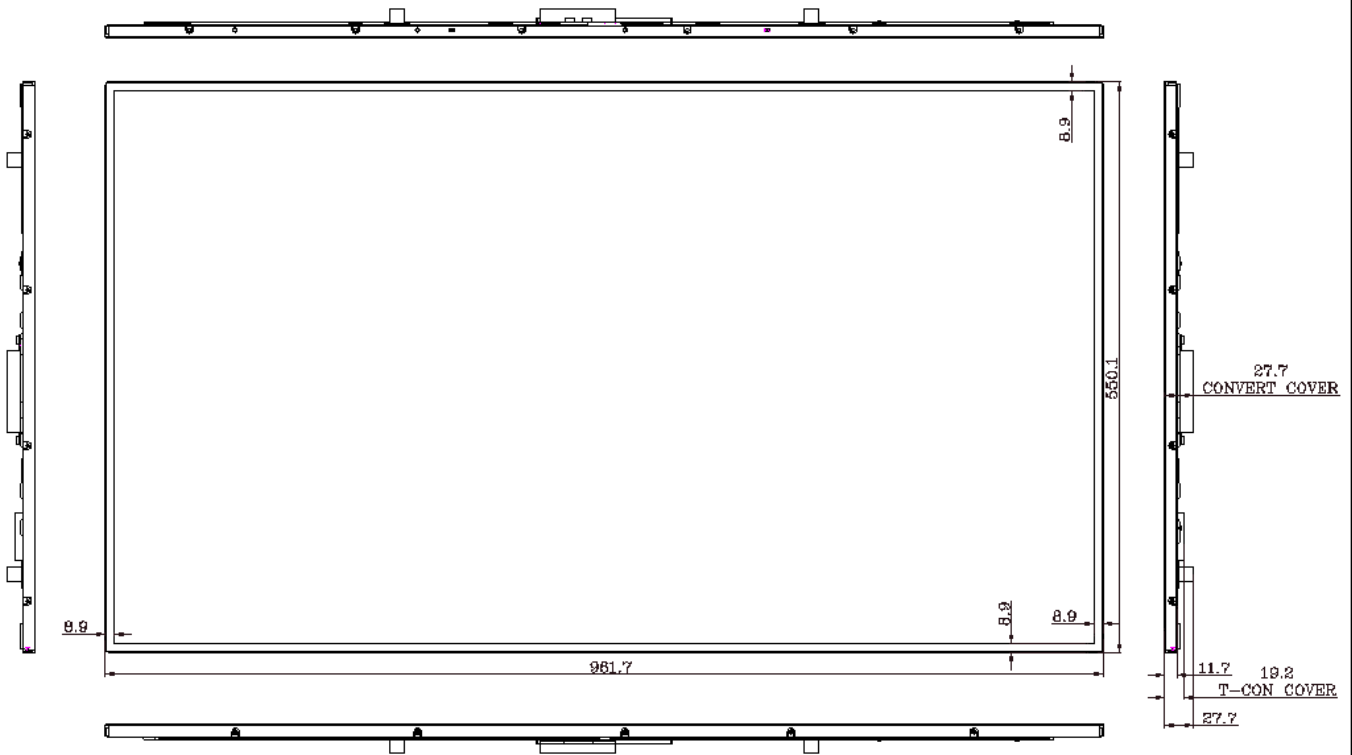

< Figure 5. TFT-LCD Module Outline Dimensions (Rear View) >

