



# 产品规格书

## Product Specification

产品名  
Product FRD130OL12002-A

机种名  
Model \_\_\_\_\_

For Customer's Acceptance	
Approved by	Comment

	Signature	Date
Prepared by		
Checked by		
Approved by		

深圳市福瑞达显示技术有限公司

地址：深圳市光明新区公明田寮第二工业区田荣路 68 号

Add:The 68th,Tianrong Road,Tianliao Community,Gongming Town,Guangming new district, shenzhen.

电话(Tel):0755-23422110

网址(Web):www.fridalcd.com

sales@fridalcd.com

# PRODUCT CONTENTS

■ PHYSICAL DATA (物理参数)	5
■ ABSOLUTE MAXIMUM RATINGS (极限参数)	6
■ EXTERNAL DIMENSIONS (外形尺寸)	7
■ ELECTRICAL CHARACTERISTICS (电气特性)	8
◆ DC Characteristics (直流特性)	8
◆ AC Characteristics (交流特性)	9
■ ELECTRO-OPTICAL CHARACTERISTICS (光电参数)	12
■ INTERFACE PIN CONNECTIONS	13
■ COMMAND TABLE	14
■ INITIALIZATION CODE	16
■ SCHEMATIC EXAMPLE	17
■ RELIABILITY TESTS (可靠性测试)	19
■ OUTGOING QUALITY CONTROL SPECIFICATION (出厂质量控制规范)	20
◆ Standard (标准)	20
◆ Definition (定义)	20
◆ Inspection Methods (检查方法)	20
◆ Inspection Criteria (检查标准)	20
■ CAUTIONS IN USING OLED MODULE (OLED 模块使用注意事项)	23
◆ Precautions for Handling OLED Module (处理 OLED 模块的注意事项)	23
◆ Precautions for Storing OLED Module (OLED 模块存储注意事项)	26
◆ Using OLED Modules (OLED 模块使用注意事项)	27
◆ Precautions for Soldering OLED Module (OLED 模块焊接注意事项)	28
◆ Precautions for Operation (工作运行注意事项)	29
◆ Safety (安全)	29
◆ Limited Warranty (有限质保)	30
◆ Return OLED Module under Warranty (OLED 模块返修质保)	30
■ PRIOR CONSULT MATTER (提前商议事项)	31
■ FACTORY CONTACT INFORMATION (工厂联系信息)	31



<b>WRITTEN BY</b> 编写	<b>CHECKED BY</b> 审核	<b>APPROVED BY</b> 审批

■ PHYSICAL DATA (物理参数)

	Items 项目	Specification 规格	Unit 单位
1	Diagonal Size 尺寸	1.3	Inch
2	Resolution 分辨率	64(H) x 128(V)	Dots
3	Active Area 有效显示区域	14.70(W) x 29.42(H)	mm <sup>2</sup>
4	Outline Dimension 外围尺寸	17.10(W) x 35.80(H)	mm <sup>2</sup>
5	Pixel Pitch 像素间距	0.23 (W) x 0.23 (H)	mm <sup>2</sup>
6	Pixel Size 像素尺寸	0.21 (W) x 0.21 (H)	mm <sup>2</sup>
7	Driver IC 驱动 IC	SH1107	-
8	Display Color 显示色彩	White	-
9	Gray Scale 灰阶	1	Bit
10	Interface 接口	4-SPI/I2C	-
11	IC Package Type IC 封装类型	COG	-
12	Module Connecting Type 模块连接方式	Plug in	-
13	Thickness 厚度	1.43 ±0.1	mm
14	Weight 重量	2 ± 10%	g
15	Duty 占空比	1/64	-

## ■ ABSOLUTE MAXIMUM RATINGS (极限参数)

Unless otherwise specified, VSS = 0V

(Ta=25°C)

除另行规定外, VSS=0V

Items 项目	Min. 最小值	Max. 最大值	Unit 单位	Remark 备注
Supply Voltage(VDD) 逻辑电压 (VDD)	-0.3	+3.6	V	IC maximum rating IC 极限参数
Supply Voltage(VPP) 驱动电压 (VPP)	-0.3	+17.0	V	IC maximum rating IC 极限参数
Operating Temperature(T <sub>OP</sub> ) 操作温度 (T <sub>OP</sub> )	-10	50	°C	-
Storage Temperature(T <sub>ST</sub> ) 存储温度 (T <sub>SP</sub> )	-20	60	°C	Note 2

### NOTE:

1. Permanent device damage may occur if ABSOLUTE MAXIMUM RATINGS are exceeded. Functional operation should be restricted to the conditions as detailed in the operational sections of this data sheet. Exposure to absolute maximum rating conditions for extended periods may affect reliability.  
如果超过极限参数可能会导致器件永久性损坏。实际工作条件应仅限于在本数据表格中详述的操作部分。在极限参数条件下长时间工作会影响其可靠性。
2. The defined temperature ranges do not include the polarizer. The maximum withstood temperature of the polarizer should be 60 °C.  
定义的温度范围不包括偏光片。偏光片的最大值耐温应为 60°C。

# EXTERNAL DIMENSIONS (外形尺寸)

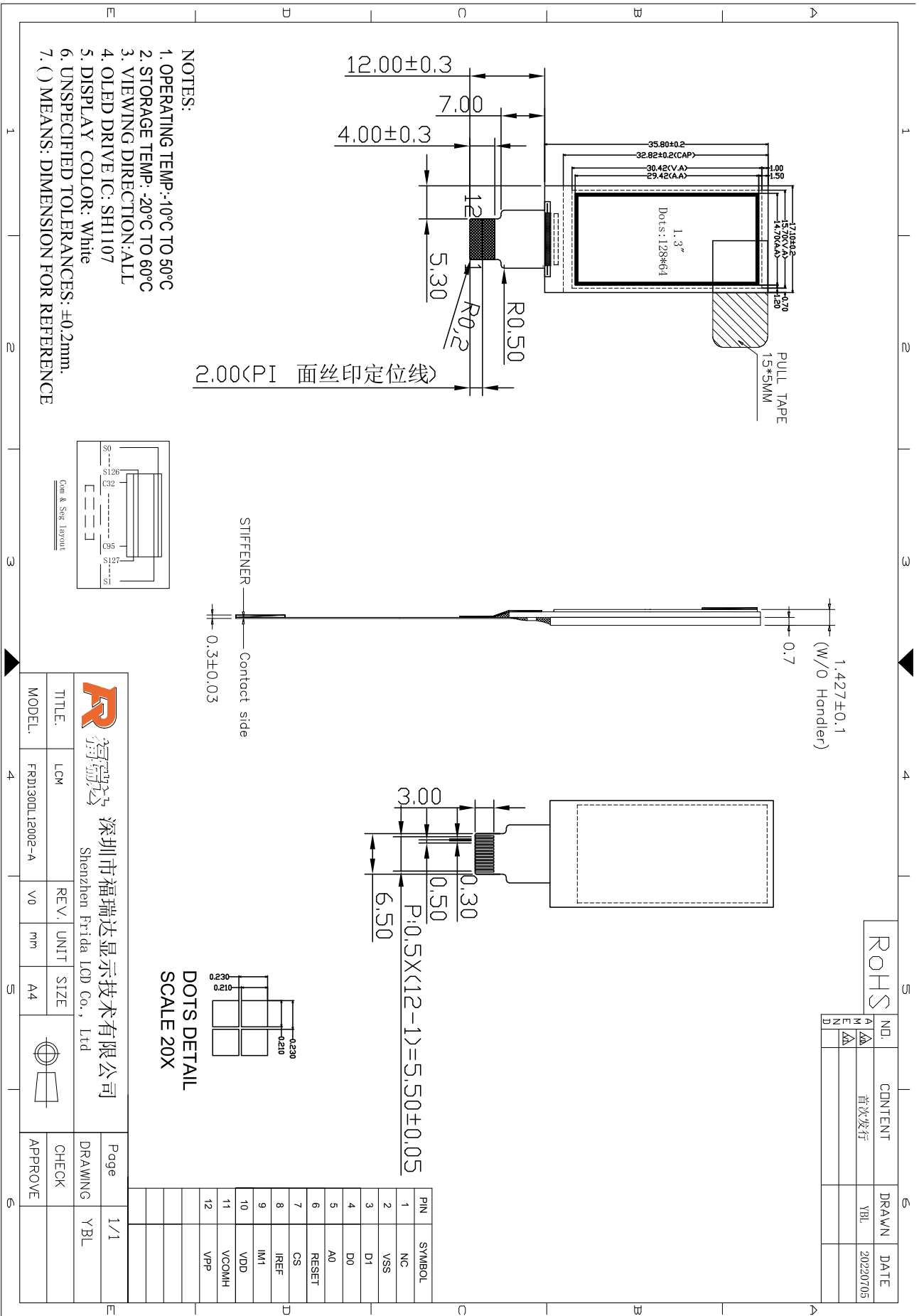

- NOTES:
1. OPERATING TEMP: -10°C TO 50°C
  2. STORAGE TEMP: -20°C TO 60°C
  3. VIEWING DIRECTION: ALL
  4. OLED DRIVE IC: SH1107
  5. DISPLAY COLOR: White
  6. UNSPECIFIED TOLERANCES: ±0.2mm.
  7. ( ) MEANS: DIMENSION FOR REFERENCE

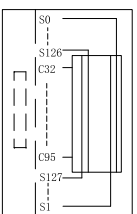

ROHS		NL		CONTENT		DRAWN		DATE	
A	△	M	△	首次发行	YBL	20220705			
M	△	N	△						

**FR** 福瑞达显示技术有限公司  
Shenzhen Frida LCD Co., Ltd

TITLE:	LCM	REV:	UNIT	SIZE	Page
MODEL:	FRD130DL12002-A	V0	mm	A4	DRAWING
					CHECK
					APPROVE
					YBL
					1/1

## ■ ELECTRICAL CHARACTERISTICS (电气特性)

### ◆ DC Characteristics (直流特性)

Unless otherwise specified, Voltage referenced to VSS;

除另行规定外，参考电平为 VSS；

VDD=2.8V, VPP = 9.0V, IREF = 10uA,

(Ta = 22 ± 3°C, 60 ± 10%RH)

Items 项目		Symbol 符号	Min. 最小值	Typ. 典型值	Max. 最大值	Unit 单位
Supply Voltage 供电电压	Logic Supply Voltage IC 逻辑电压	V <sub>DD</sub>	1.65	3.0	3.5	V
	Operating (for OLED panel) 操作电压 (供 OLED 面板)	V <sub>PP</sub>	7.0	15	16.5	V
Input Voltage 输入电压	High Voltage 高电平	V <sub>IH</sub>	0.8 x V <sub>DD</sub>	-	V <sub>DD</sub>	V
	Low Voltage 低电平	V <sub>IL</sub>	0	-	0.2 x V <sub>DD</sub>	V
Output Voltage 输出电压	High Voltage 高电平	V <sub>OH</sub>	0.8 x V <sub>DD</sub>	-	V <sub>DD</sub>	V
	Low Voltage 低电平	V <sub>OL</sub>	V <sub>SS</sub>	-	0.2 x V <sub>DD</sub>	V

◆ AC Characteristics (交流特性)

1. 4-SPI Serial Interface Timing Characteristics

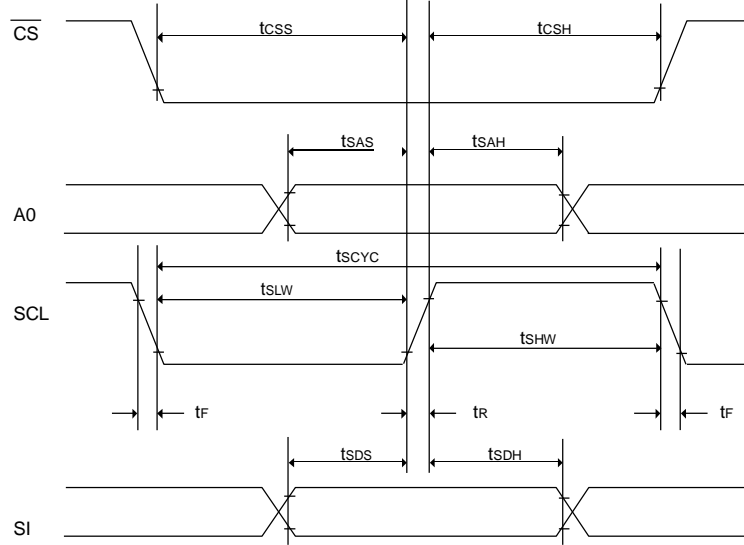

( $V_{DD1} = 1.65 - 2.4V, T_A = +25^\circ C$ )

Symbol	Parameter	Min.	Typ.	Max.	Unit	Condition
tSCYC	Serial clock cycle	500	-	-	ns	
tSAS	Address setup time	300	-	-	ns	
tSAH	Address hold time	300	-	-	ns	
tSDS	Data setup time	200	-	-	ns	
tSDH	Data hold time	200	-	-	ns	
tCSS	$\overline{CS}$ setup time	240	-	-	ns	
tCSH	$\overline{CS}$ hold time	120	-	-	ns	
tSHW	Serial clock H pulse width	200	-	-	ns	
tSLW	Serial clock L pulse width	200	-	-	ns	
tR	Rise time	-	-	30	ns	
tF	Fall time	-	-	30	ns	

( $V_{DD1} = 2.4 - 3.5V, T_A = +25^\circ C$ )

Symbol	Parameter	Min.	Typ.	Max.	Unit	Condition
tSCYC	Serial clock cycle	250	-	-	ns	
tSAS	Address setup time	150	-	-	ns	
tSAH	Address hold time	150	-	-	ns	
tSDS	Data setup time	100	-	-	ns	
tSDH	Data hold time	100	-	-	ns	
tCSS	$\overline{CS}$ setup time	120	-	-	ns	
tCSH	$\overline{CS}$ hold time	60	-	-	ns	
tSHW	Serial clock H pulse width	100	-	-	ns	
tSLW	Serial clock L pulse width	100	-	-	ns	
tR	Rise time	-	-	15	ns	
tF	Fall time	-	-	15	ns	

## 2. I2C Serial Interface Timing Characteristics

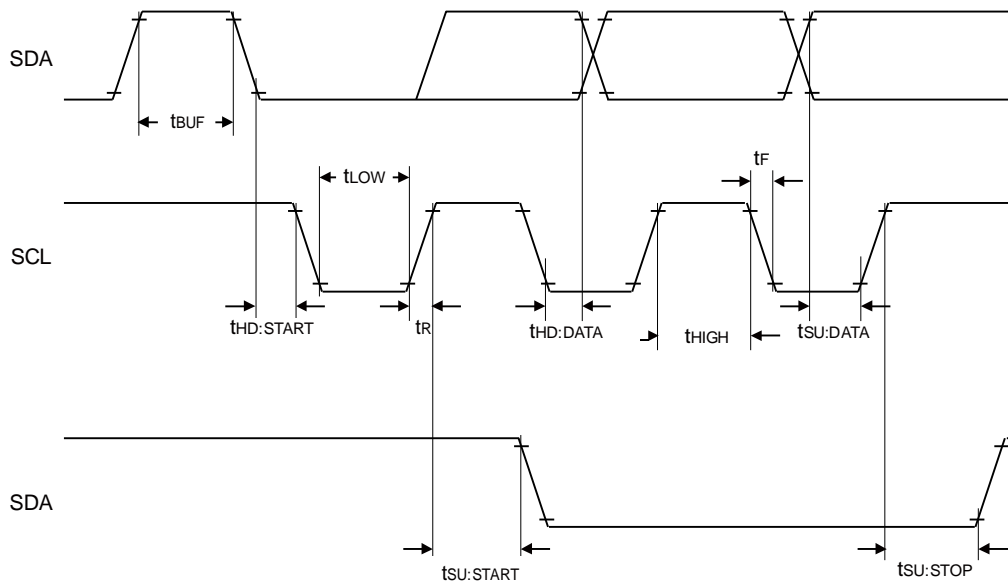

( $V_{DD} = 1.65 - 3.5V$ ,  $T_A = +25^\circ C$ )

Symbol	Parameter	Min.	Typ.	Max.	Unit	Condition
fSCL	SCL clock frequency	DC	-	400	kHz	
TLOW	SCL clock Low pulse width	1.3	-	-	$\mu s$	
THIGH	SCL clock H pulse width	0.6	-	-	$\mu s$	
TSU:DATA	data setup time	100	-	-	ns	
T <sub>HD</sub> :DATA	data hold time	0	-	0.9	$\mu s$	
TR	SCL& SDA rise time	$20+0.1C_b$	-	300	ns	
TF	SCL& SDA fall time	$20+0.1C_b$	-	300	ns	
C <sub>b</sub>	Capacity load on each bus line	-	-	400	pF	
TSU:START	Setup time for re-START	0.6	-	-	$\mu s$	
T <sub>HD</sub> :START	START Hold time	0.6	-	-	$\mu s$	
TSU:STOP	Setup time for STOP	0.6	-	-	$\mu s$	
T <sub>BUF</sub>	Bus free times between STOP and START condition	1.3	-	-	$\mu s$	

### 3. Reset Timing

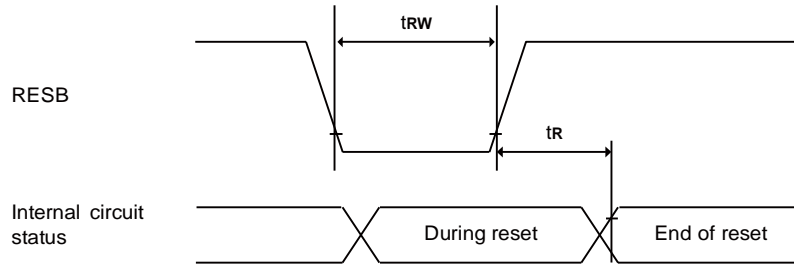

(VDD = 1.65 - 3.5V, TA = +25 C)

Symbol	Parameter	Min.	Typ.	Max.	Unit	Condition
tR	Reset time	-	-	2.0	s	
tRW	Reset low pulse width	10.0	-	-	s	

### 4. Power on and off sequence

Power on sequence :

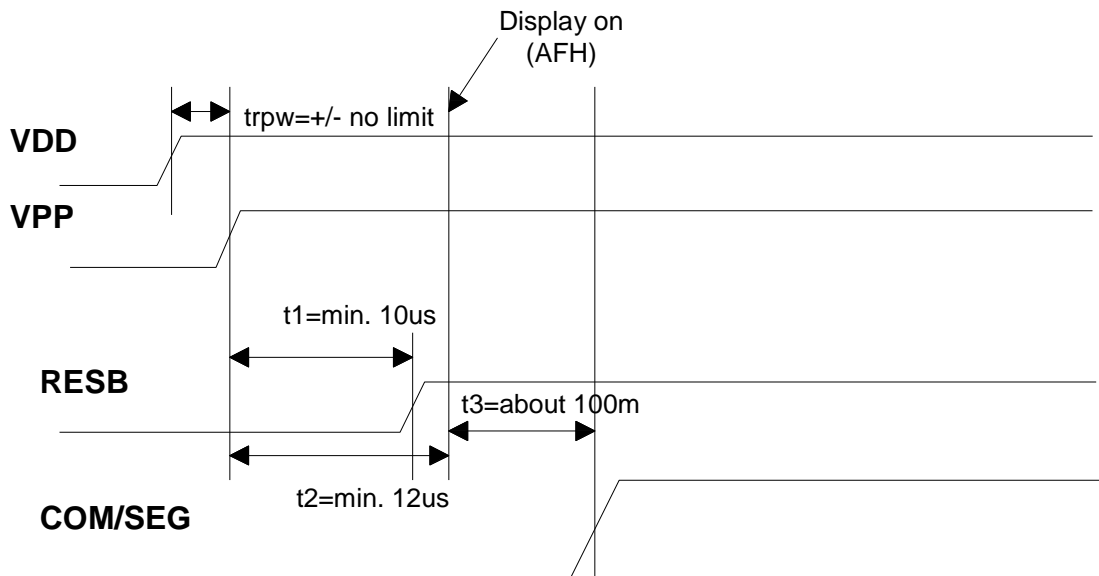

Power off sequence :

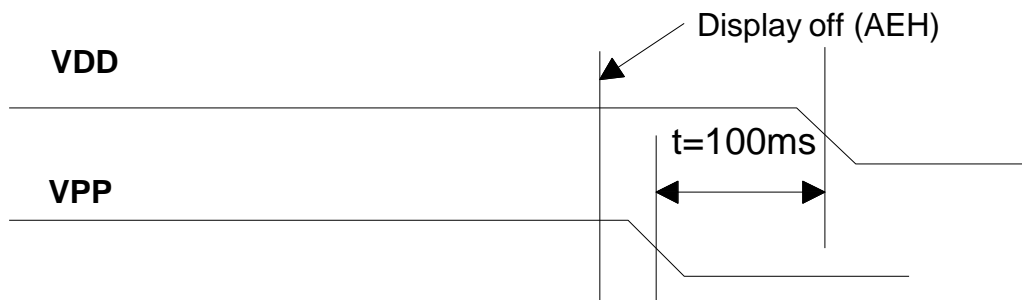

## ■ ELECTRO-OPTICAL CHARACTERISTICS (光电参数)

All data in below based the condition ( $T_a = 22 \pm 3^\circ\text{C}$ ,  $60 \pm 10\% \text{RH}$ ).

以下参数均基于  $T_a = 22 \pm 3^\circ\text{C}$ ,  $60 \pm 10\% \text{RH}$  的条件。

Items 项目		Symbol 符号	Min. 最小值	Typ. 典型值	Max. 最大值	Unit 单位	Remark 备注
Operating Luminance 工作亮度		L	70	90*	-	cd/m <sup>2</sup>	-
Color Coordinate 色坐标	White	CIE x	0.24	0.28	0.32	CIE1931	Darkroom
		CIE y	0.27	0.31	0.35		
Operating Life Time* 工作寿命		Top	20,000	-	-	Hours	L= 90 cd/m <sup>2</sup>

### Note(注意事项):

1.  $L=90 \text{ cd/m}^2$  is based on  $VDD=3.0\text{V}$ ,  $VPP=13.0\text{V}$ , Contrast command setting 0x2F.

$L=90 \text{ cd/m}^2$  基于  $VDD=3.0\text{V}$ ,  $VPP=13.0\text{V}$ , 对比度设置为 0x2F。

2. **Life Time** is defined when the Luminance has decayed to less than 50% of the initial Luminance specification.

(Odd and even chess board alternately displayed).

(The initial value should be closed to the typical value after adjusting.)

寿命的定义为当亮度衰减到初始亮度 50%时所消耗的时间。

(奇数和偶数棋盘交替显示)。

(初始亮度值应调试到接近典型值的大小)。

The above data are the data of OLED MODULE with polarizer, for reference only.

以上数据为带偏光片的 OLED 模块数据，仅供参考。

## ■ INTERFACE PIN CONNECTIONS

No.	Symbol	Description
1	NC	No connection.
2	VSS	Ground.
3	D1	Serial data input.
4	D0	Serial clock input.
5	A0/DC	This is the Data/Command control pad that determines whether the data bits are data or a command. A0 = "H": the inputs at D0 to D7 are treated as display data. A0 = "L": the inputs at D0 to D7 are transferred to the command registers. In I2C interface, this pad serves as SA0 to distinguish the different address of OLED driver.
6	RES	This is a reset signal input pad. When RES is set to "L", the settings are initialized. The reset operation is performed by the RES signal level.
7	CS	This pad is the chip select input. When CS = "L", then the chip select becomes active, and data/command I/O is enabled.
8	IREF	This is a segment current reference pad. A resistor should be connected between this pad and VSS. Set the current at 15.625 $\mu$ A.
9	IM1	L:4-SPI    H:I <sup>2</sup> C
10	VDD	1.65 - 3.5V Power supply for logic and input.
11	VCOMH	This is a pad for the voltage output high level for common signals. A capacitor should be connected between this pad and VSS.
12	VPP	This is the most positive voltage supply pad of the chip. It should be supplied externally.

## ■ COMMAND TABLE

Command	Code											Function	
	A0	$\overline{RD}$	$\overline{WR}$	D7	D6	D5	D4	D3	D2	D1	D0		
1. Set Column Address 4 lower bits	0	1	0	0	0	0	0	Lower column address				0	Sets 4 lower bits of column address of display RAM in register. (POR = 00H)
2. Set Column Address 4 higher bits	0	1	0	0	0	0	1	0	Higher column address			0	Sets 4 higher bits of column address of display RAM in register. (POR = 10H)
3. Set memory addressing mode	0	1	0	0	0	1	0	0	0	0	D	D = 1, Vertical Addressing Mode D = 0, Page Addressing Mode (POR=20H)	
4. The Contrast Control Mode Set	0	1	0	1	0	0	0	0	0	0	1	This command is to set Contrast Setting of the display. The chip has 256 contrast steps from 00 to FF. (POR = 80H)	
Contrast Data Register Set	0	1	0	Contrast Data									
5. Set Segment Re-map (ADC)	0	1	0	1	0	1	0	0	0	0	ADC	The down (0) or up (1) rotation. (POR = A0H)	
6. Set Multiplex Ration	0	1	0	1	0	1	0	1	0	0	0	This command switches multiplex mode to any multiplex ratio from 1 to 128. (POR = 7FH )	
	0	1	0	-	Multiplex Ratio								
7. Set Entire Display OFF/ON	0	1	0	1	0	1	0	0	1	0	D	Selects normal display (0) or Entire Display ON (1). (POR = A4H)	
8. Set Normal/ Reverse Display	0	1	0	1	0	1	0	0	1	1	D	Normal indication (0) when low, but reverse indication (1) when high. (POR = A6H)	
9. Set display offset	0	1	0	1	1	0	1	0	0	1	1	This is a double byte command that specifies the mapping of display start line to one of COM0 -127. (POR = 00H)	
	0	1	0	-	COMx								
10. DC-DC Control Mode Set DC-DC Setting Mode Set	0	1	0	1	0	1	0	1	1	0	1	This command is to control the DC-DC voltage DC-DC will be turned on when display on converter (1) or DC-DC OFF (0). (POR = 81H)	
	0	1	0	1	0	0	0	F2	F1	F0	D		

Command	Code											Function
	A0	$\overline{RD}$	$\overline{WR}$	D7	D6	D5	D4	D3	D2	D1	D0	
11. Display OFF/ON	0	1	0	1	0	1	0	1	1	1	D	Turns on OLED panel (1) or turns off (0). (POR = AEH)
12. Set Page Address	0	1	0	1	0	1	1	Page Address				Specifies page address to load display RAM data to page address register. (POR = B0H)
13 Set Common Output Scan Direction	0	1	0	1	1	0	0	D	*	*	*	Scan from COM0 to COM [N - 1] (0) or Scan from COM [N - 1] to COM0 (1). (POR = C0H)
14. Set Display Divide Ratio/Oscillator Frequency Mode Set	0	1	0	1	1	0	1	0	1	0	1	This command is used to set the frequency of the internal display clocks. (POR = 50H)
Divide Ratio/Oscillator Frequency Data Set	0	1	0	Oscillator Frequency				Divide Ratio				
15. Dis-charge / Pre-charge Period Mode Set	0	1	0	1	1	0	1	1	0	0	1	This command is used to set the duration of the dis-charge and pre-charge period. (POR = 22H)
Dis-charge /Pre-charge Period Data Set	0	1	0	Dis-charge Period				Pre-charge Period				
16. VCOM Deselect Level Mode Set	0	1	0	1	1	0	1	1	0	1	1	This command is to set the common pad output voltage level at deselect stage. (POR = 35H)
VCOM Deselect Level Data Set	0	1	0	VCOM = ( $\beta_1$ X VREF )								
17. Set Display Start Line	0	1	0	1	1	0	1	1	1	0	0	Specify RAM display line for COM0.
	0	1	0	-	Start line							
18. Read-Modify-Write	0	1	0	1	1	1	0	0	0	0	0	Read-Modify-Write start.
19. End	0	1	0	1	1	1	0	1	1	1	0	Read-Modify-Write end.
20. NOP	0	1	0	1	1	1	0	0	0	1	1	Non-Operation Command
21 Write Display Data	1	1	0	Write RAM data								
22 Read ID	0	0	1	BUSY	ON/OFF	ID						
23. Read Display Data	1	0	1	Read RAM data								

**Note:** \*Do not use any other commands, or the system malfunction may result.

\*When the display OFF command(AEH) is executed, power saver mode(**Sleep mode**) will be entered.

This mode stops every operation of the OLED display system, and can reduce current consumption nearly to a static current value if no access is made from the microprocessor. The internal status in the sleep mode is as follows:

- 1) Stops the oscillator circuit.
- 2) Stops the OLED drive and outputs Hz as the segment/common driver output.
- 3) Holds the display data and operation mode provided before the start of the sleep mode.
- 4) The MPU can access to the built-in display RAM.

## ■ INITIALIZATION CODE

```
void Init_SH1107G(void)
{
    Write_Command(0xAE);           // Display OFF

    Write_Command(0xA8);           // Set Multiplex Ration
    Write_Command(0x3F);

    Write_Command(0xD5);           // Set Frame Frequency
    Write_Command(0xF1);

    Write_Command(0xC0);           // Set Common scan direction

    Write_Command(0xD3);           // Set Display Offset
    Write_Command(0x60);

    Write_Command(0xDC);           // Set Display Start Line
    Write_Command(0x20);

    Write_Command(0x20);           // Set Page Addressing Mode

    Write_Command(0x81);           // Set Contrast Control
    Write_Command(0x6E);

    Write_Command(0xA0);           // Set Segment Re-map

    Write_Command(0xA4);           // Set Entire Display OFF/ON

    Write_Command(0xA6);           // Set Normal/Reverse Display
    Write_Command(0xAD);           // Set External VPP
    Write_Command(0x8A);

    Write_Command(0xD9);           // Set Phase Leghth
    Write_Command(0x22);

    Write_Command(0xDB);           // Set VCOMH Voltage
    Write_Command(0x35);

    ClearRAM();

    Write_Command(0xAF);           //Display ON
}
```

## ■ SCHEMATIC EXAMPLE

◆ Serial Interface Application Circuit:

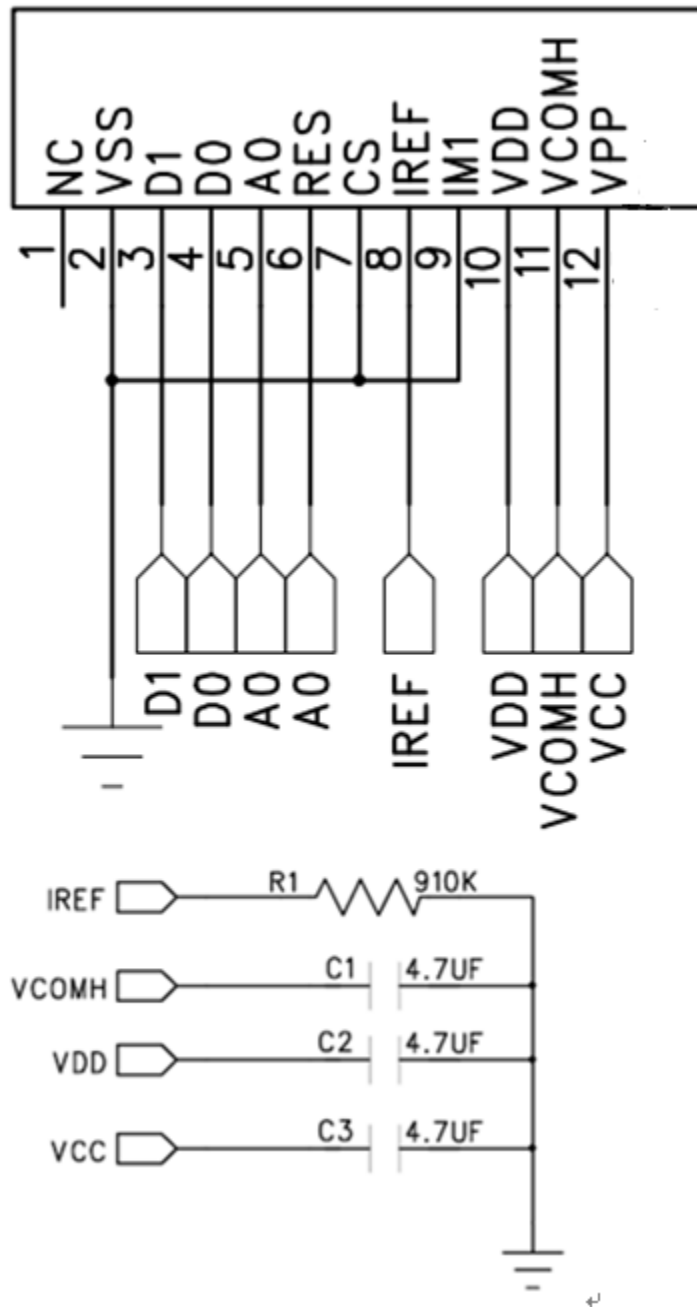

◆ IIC Interface Application Circuit:

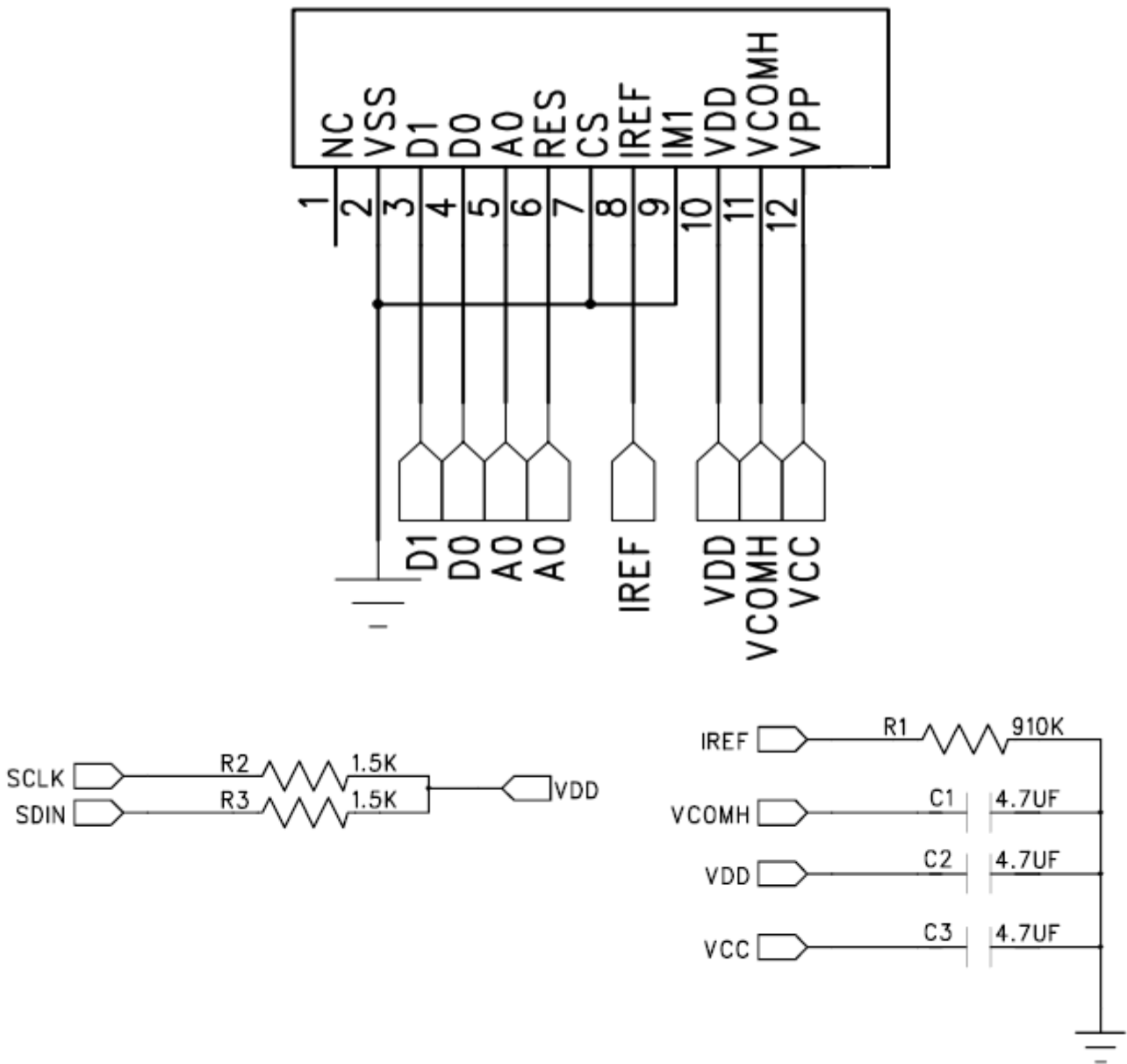

**NOTE:**

1. The VCOMH capacitor is recommended to use tantalum capacitor to reduce noise.
2. The capacitor and the resistor value are recommended value. Select the appropriate value against module application.

## ■ RELIABILITY TESTS (可靠性测试)

NO.	Item	Condition	Quantity
1	High Temperature Storage (HTS)	60 ±2°C, 96 hours	3
2	High Temperature Operating (HTO)	50 ±2°C, 96 hours	3
3	Low Temperature Storage (LTS)	-20±2°C, 96hours	3
4	Low Temperature Operating (LTO)	-10±2°C, 96 hours	3
5	High Temperature / High Humidity Storage (HTHHS)	40±3°C, 90% ±3%RH,48hours	3
6	Thermal Shock (Non-operation) (TS)	-20±2°C ~ 25°C ~ 60±2°C (30min) (5min) (30min) 5cycles	3
7	Vibration (Packing)	10~55~10Hz, amplitude 1.5mm, 1 hour for each direction x, y, z	1 Carton
8	Drop (Packing)	Height : 1 m, each time for 6 sides, 3 edges, 1 angle	1 Carton
9	ESD (finished product housing)	±4kVR:330Ω; C:150pF 10times,air discharge	3

### Test and measurement conditions (测试与测量条件)

1. All measurements shall not be started until the specimens attain to temperature stability.
2. The degradation of Polarizer is ignored for item 1, 3 & 4.

### Evaluation criteria (评估标准)

1. The function test is ok.
2. No addition to the defect.
3. The change of luminance should be within ±50% of initial value.
4. The change for the color must be within (±0.02)of initial value based on 1931 CIE coordinates.
5. The change of total current consumption should be within ±50% of initial value.
6. In case of malfunction or defect caused by ESD damage, it would be judged as a good part if it would be recovered to normal state after resetting.

## ■ OUTGOING QUALITY CONTROL SPECIFICATION (出厂质量控制规范)

### ◆ Standard (标准)

According to GB/T2828.1-2003/ISO 2859-1: 1999 and ANSI/ASQC Z1.4-1993, General Inspection Level II.

### ◆ Definition (定义)

1. Major defect: The defect that greatly affect the usability of product.
2. Minor defect: The other defects, such as cosmetic defects, etc.
3. Definition of inspection zone:

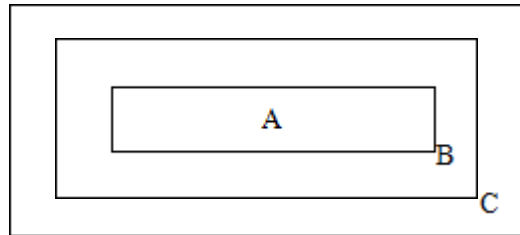

Zone A: Active Area

Zone B: Viewing Area except Zone A

Zone C: Outside Viewing Area

Note: As a general rule, visual defects in Zone C are permissible, when it is no trouble of quality and assembly to customer`s product.

### ◆ Inspection Methods (检查方法)

1. The general inspection: under 20W x 2 or 40W fluorescent light, about 30cm viewing distance, within 45 °viewing angle, under  $25 \pm 5^\circ\text{C}$ .

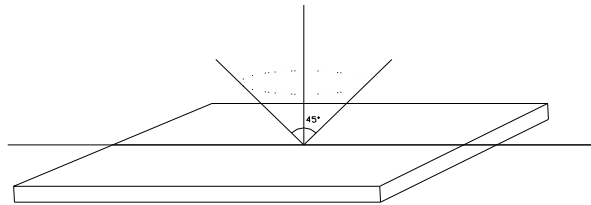

2. The luminance and color coordinate inspection: By CS2000/09A-OLED-117 or the equal equipment, in the dark room, under  $25 \pm 5^\circ\text{C}$ .

### ◆ Inspection Criteria (检查标准)

1. Major defect: AQL= 0.65

Item	Criterion
Function Defect	1. No display or abnormal display is not accepted
	2. Open or short is not accepted.
	3. Power consumption exceeding the spec is not accepted.
Outline Dimension	Outline dimension exceeding the spec is not accepted.
Glass Crack	Glass crack tends to enlarge is not accepted.

2. Minor Defect: AQL= 1.5

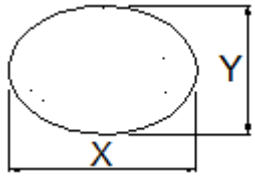
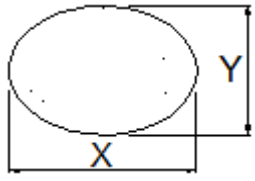
Item	Criterion				
Spot Defect (dimming and lighting spot)	Size (mm)		Accepted Qty.		
			Area A + Area B	Area C	
		$\Phi \leq 0.10$		Ignored	
		$0.10 < \Phi \leq 0.15$		3	Ignored
		$0.15 < \Phi \leq 0.20$		1	
$0.20 < \Phi$		0			
Note : $\Phi = (x + y) / 2$					
Line Defect (dimming and lighting line)	L ( Length ) : mm	W ( Width ) : mm	Area A + Area B	Area C	
	/	$W \leq 0.02$	Ignored		
	$L \leq 3.0$	$0.02 < W \leq 0.03$	2	Ignored	
	$L \leq 2.0$	$0.03 < W \leq 0.05$	1		
	/	$0.05 < W$	As spot defect		
Remarks: The total of spot defect and line defect shall not exceed 4 PCS. The distance between two lines defects must exceed 1 mm					
Polarizer Stain	Stain which can be wiped off lightly with a soft cloth or similar cleaning is accepted, otherwise, according to the Spot Defect and the Line Defect.				
Polarizer Scratch	1. If scratch can be seen during operation, according to the criterions of the Spot Defect and the Line Defect.				
	2. If scratch can be seen only under non-operation or some special angle, the criterion is as below:				
	L ( Length ) : mm	W ( Width ) : mm	Area A + Area B	Area C	
	/	$W \leq 0.02$	Ignore		
	$3.0 < L \leq 5.0$	$0.02 < W \leq 0.04$	2	Ignore	
	$L \leq 3.0$	$0.04 < W \leq 0.06$	1		
/	$0.06 < W$	0			
Polarizer Air Bubble	Size		Area A + Area B	Area C	
		$\Phi \leq 0.20$		Ignored	
		$0.20 < \Phi \leq 0.30$		2	Ignored
		$0.30 < \Phi \leq 0.50$		1	
		$0.50 < \Phi$		0	

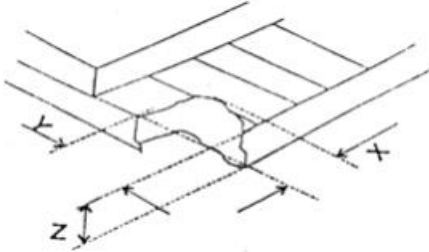
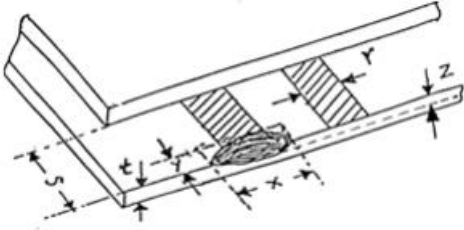
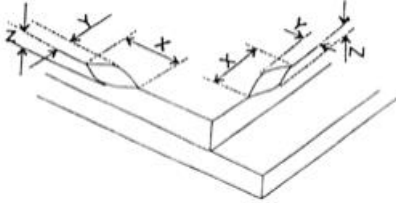
Glass Defect (Glass Chipped)	1. on the corner (mm)	 <table border="1" style="margin-left: auto; margin-right: auto;"> <tr> <td><b>x</b></td> <td><math>\leq 1.5</math></td> </tr> <tr> <td><b>y</b></td> <td><math>\leq 1.5</math></td> </tr> <tr> <td><b>z</b></td> <td><math>\leq t</math></td> </tr> </table>	<b>x</b>	$\leq 1.5$	<b>y</b>	$\leq 1.5$	<b>z</b>	$\leq t$
	<b>x</b>	$\leq 1.5$						
	<b>y</b>	$\leq 1.5$						
	<b>z</b>	$\leq t$						
2. On the bonding edge (mm)	 <table border="1" style="margin-left: auto; margin-right: auto;"> <tr> <td><b>x</b></td> <td><math>\leq a/4</math></td> </tr> <tr> <td><b>y</b></td> <td><math>\leq s/3 \ \&amp; \ \leq 0.7</math></td> </tr> <tr> <td><b>z</b></td> <td><math>\leq t</math></td> </tr> </table>	<b>x</b>	$\leq a/4$	<b>y</b>	$\leq s/3 \ \& \ \leq 0.7$	<b>z</b>	$\leq t$	
<b>x</b>	$\leq a/4$							
<b>y</b>	$\leq s/3 \ \& \ \leq 0.7$							
<b>z</b>	$\leq t$							
3. On the other edges (mm)	 <table border="1" style="margin-left: auto; margin-right: auto;"> <tr> <td><b>x</b></td> <td><math>\leq a / 8</math></td> </tr> <tr> <td><b>y</b></td> <td><math>\leq 0.7</math></td> </tr> <tr> <td><b>z</b></td> <td><math>\leq t</math></td> </tr> </table>	<b>x</b>	$\leq a / 8$	<b>y</b>	$\leq 0.7$	<b>z</b>	$\leq t$	
<b>x</b>	$\leq a / 8$							
<b>y</b>	$\leq 0.7$							
<b>z</b>	$\leq t$							
Note: t: glass thickness; s: pad width; a: the length of the edge.								
TCP Defect	Crack, deep fold and deep pressure mark on the TCP are not accepted							
Pixel Size	The tolerance of display pixel dimension should be within $\pm 20\%$ of the spec.							
Luminance	Refer to the spec or the reference sample.							
Color	Refer to the spec or the reference sample.							

## ■ CAUTIONS IN USING OLED MODULE (OLED 模块使用注意事项)

### ◆ Precautions for Handling OLED Module (处理 OLED 模块的注意事项)

1. The display panel is made of glass and polarizer. As glass is fragile. It tends to become chipped during handling especially on the edges. Please avoid dropping or jarring. Do not subject it to a mechanical shock by dropping it or impact.

显示屏由玻璃和偏光片组成。由于玻璃是脆弱的，使用过程中要特别防止边缘区损伤。请避免显示屏因跌落或振动而受到机械冲击。

2. Do not apply excessive force to the display surface or the adjoining areas since this may cause abnormal. Do not touch the display with bare hands. This will stain the display area (some cosmetics are determined to the polarizer).

请勿施加过大的压力于显示屏或连接部位，否则可能会引起显示异常。不要用手接触显示屏，这将弄脏显示区（一些外观是由偏光片决定的）。

3. The polarizer covering the display surface of the OLED module is soft and easily scratched. Handle this polarizer carefully. Do not touch, push or rub the exposed polarizers with anything harder than an HB pencil lead (glass, tweezers, etc.). Do not put or attach anything on the display area to avoid leaving marks on it. Condensation on the surface and contact with terminals due to cold will damage, stain or dirty the polarizer. After products are tested at low temperature they must be warmed up in a container before coming in to contact with room temperature air.

覆盖 OLED 显示模块显示平面的偏光片是软性的且易被擦伤，请小心，轻拿。请勿用任何硬度大于 HB 铅笔芯的物品（玻璃，镊子等）接触、撞压或摩擦裸露偏光片。不要放置或粘附物体在显示区域上以免留下痕迹。冷凝在表面和端子将会损坏或弄脏偏光片。产品在低温下测试之后，与室温空气接触之前必须在容器内升温。

4. If the display surface becomes contaminated, breathe on the surface and gently wipe it with a soft dry cloth. If it is heavily contaminated, moisten cloth with one of the following solvents.

- Isopropyl alcohol
- Ethyl alcohol

Do not scrub hard to avoid damaging the display surface.

如果显示平面受污，可对平面吹热气且轻轻地用软性干布擦除。如果受污严重，用含下列一种溶剂的湿布擦除：

- 甘油
- 酒精

请勿用力擦拭以免损坏显示平面。

5. Solvents other than those above-mentioned may damage the polarizer. Especially, do not use the following.

- Water
- Ketone
- Aromatic solvents

Wipe off saliva or water drops immediately, contact with water over a long period of time may cause deformation or color fading. Avoid contact with oil and fats.

除以上提到的溶剂外，其他溶剂可能会损坏偏光片，特别要避免使用以下溶剂：

- 水
- 酮
- 芳烃溶剂

立即擦掉唾液或水滴，长时间与水接触会引起变形或褪色。避免接触油和油脂。

6. Exercise care to minimize corrosion of the electrode. Corrosion of the electrodes is accelerated by water droplets, moisture condensation or a current flow in a high-humidity environment.

特别注意最小限度地减少电极腐蚀，电极腐蚀会因水滴、湿度冷凝或高湿环境下通电而加速。

7. When mounting the OLED module make sure it is free of twisting, warping and distortion. In particular, do not forcibly pull or bend the I/O cable.



安装 OLED 模块时一定不要弯曲、扭曲和变形。要特别注意不要用力拔，弯曲传输线。

8. Do not attempt to disassemble or process the OLED module.  
请勿拆卸 OLED 模块。
9. NC terminal should be open. Do not connect anything.  
悬空端应断开，不要连接任何器件。
10. If the logic circuit power is off, do not apply the input signals.  
如果逻辑电路电源是断开的，不要施加输入信号。
11. Electro-Static Discharge Control, Since this module uses a CMOS LSI, the same careful attention should be paid to electrostatic discharge as for an ordinary CMOS IC. To prevent destruction of the elements by static electricity, be careful to maintain an optimum work environment.  
由于 OLED 显示模块使用 CMOS 集成，要特别注意静电放电问题。对 CMOS 器件，要特别注意静电。为防止静电造成的损坏，注意保持合宜的工作环境。
  - Before removing OLED from its packing case or incorporating it into a set, be sure the module and your body have the same electric potential. Be sure to ground the body when handling the OLED modules.  
- OLED 模块移出包装盒和安装之前，要保证模块和人体具有相同的电位。处理模块时可靠接地。
  - Tools required for assembling, such as soldering irons, must be properly grounded. Make certain the AC power source for the soldering iron does not leak. When using an electric screwdriver to attach LCM, the screwdriver should be of ground potentiality to minimize as much as possible any transmission of electromagnetic waves produced sparks coming from the commutator of the motor.  
- 使用工具如电烙铁，必须正确接地，并确保烙铁使用的交流电不会漏电。用电动螺丝刀固定模块时，电动螺丝刀应接地，尽可能降低电动换向器火花产生的电磁波。
  - To reduce the amount of static electricity generated, do not conduct assembling and other work under dry conditions. To reduce the generation of static electricity be careful that the air in the work is not too dry. A relative humidity of 50%-60% is recommended. As far as possible make the electric potential of your work clothes and that of the work bench the ground potential.  
- 为减少静电产生，不要在干燥的条件下进行组装等工作。为降低静电，工作环境一定不要干燥。建议相对湿度为 50%-60%。尽可能使你的工作服和工作台接地。
  - The OLED module is coated with a film to protect the display surface. Exercise care when peeling off this protective film since static electricity may be generated.  
- OLED 模块表面有保护膜。需要小心操作因为撕保护膜时可能产生静电。





12. OLED module is easy to be damaged. Please note below and be careful for handling.

OLED 显示模块很容易被损坏. 请注意以下并小心操作

i. Correct handling (正确操作):

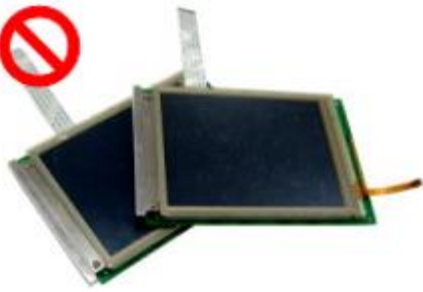
	
<p>As above picture, please handle with anti-static gloves around OLED module edges. 像上面的图片,请戴抗静电手套,并拿模块边缘.</p>	

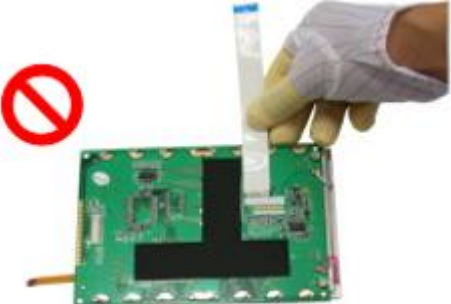
ii. Incorrect handling(错误操作):

	
<p>Don't touch IC directly 不要直接触摸 IC</p>	<p>Don't stack OLED modules 不要堆叠 OLED 模块</p>
	
<p>Don't hold the surface of panel 不要拿着面板的表面</p>	<p>Don't stretch interface of input, such as FPC 不要拉扯输入接口, 如软排线</p>
	
<p>Don't hold the surface of IC 不要拿着 IC 的表面</p>	<p>Don't operate with sharp stick such as pens 不要用尖锐的物体来操作, 如笔尖</p>

◆ **Precautions for Storing OLED Module (OLED 模块存储注意事项)**

1. When storing the OLED modules, the following precautions are necessary.

OLED 模块的存储依照以下几点:

i. Store them in a sealed polyethylene bag with the desiccant.

使用干燥剂和聚乙烯袋密封包装。

ii. Store them in a dark place. Do not expose to sunlight or fluorescent light, keep the temperature between 0°C and 35°C, and keep the relative humidity between 40%RH and 60%RH.

避光保存, 避免直接暴露在太阳光或黄光灯下, 保持温度在 0~35 摄氏度之间, 保持相对湿度在 40%RH 和 60%RH 之间。

iii. The polarizer surface should not come in contact with any other objects (We advise you to store them in the anti-static electricity container in which they were shipped).

偏光片表面避免接触其他物质 (建议存放在货运防静电包装中)。

2. Others

i. If the OLED modules have been operating for a long time, it will cause brightness decay. It is not recommended to showing the same display patterns for a long time, otherwise the display patterns may remain on the screen as ghost images and it is unrecoverable.

OLED 长时间点亮会有亮度衰减, 所以尽量避免长时间工作于同一个显示图案, 否则会造成鬼影, 这是不可恢复的。

ii. To minimize the performance degradation of the OLED modules resulting from destruction caused by static electricity etc., exercise care to avoid holding the following sections when handling the modules.

为最小限度地降低由静电等导致 OLED 模块性能降低, 使用模块时慎重使用下列区域:

- Exposed area of the printed circuit board.

印制电路板裸露区域。

-Terminal electrode sections.

印制电路板引出端子区域。

## ◆ Using OLED Modules (OLED 模块使用注意事项)

### Installing OLED Modules (安装 OLED 模块)

- i. When assembling the OLED module into other equipment, the spacer to the bit between the OLED module and the fitting plate should have enough height to avoid causing stress to the module surface, refer to the individual specifications for measurements. The measurement tolerance should be  $\pm 0.1\text{mm}$ .

将 OLED 模块安装进入其它设备时，模块和安装板之间间隔应有足够的高度以避免模块表面受压。参照专业度量技术标准。量度公差应是  $\pm 0.1$  毫米。

- ii. Precaution for assemble the module with BTB connector:

用板对板连接器安装 OLED 显示模块注意事项:

Please note the position of the male and female connector position, don't assemble or assemble like the method which the following picture shows.

请注意连接器的公母及连接位置，请勿出现下图所示的连接方式。

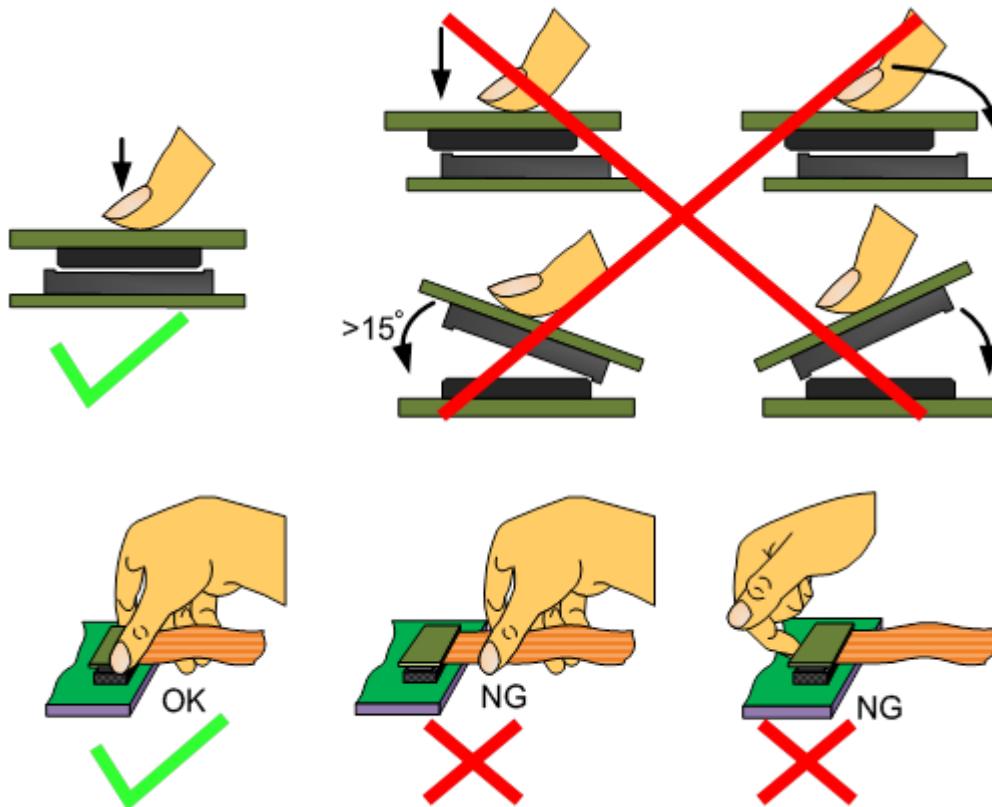

◆ **Precautions for Soldering OLED Module (OLED 模块焊接注意事项)**

	Manual soldering 手工焊接	Machine drag soldering 机器拖焊	Machine press soldering 机器压焊
No RoHS Product 非环保产品	290°C ~350°C. Time: 3-5S.	330°C ~350°C. Speed : 15-17 mm/s.	300°C ~330°C. Time: 3-6S. Press: 0.8~1.2Mpa
RoHS Product 环保产品	340°C ~370°C. Time: 3-5S.	350°C ~370°C. Speed : 15-17 mm/s.	330°C ~360°C. Time: 3-6S. Press: 0.8~1.2Mpa

1. If soldering flux is used, be sure to remove any remaining flux after finishing to soldering operation (This does not apply in the case of a non-halogen type of flux). It is recommended that you protect the OLED surface with a cover during soldering to prevent any damage due to flux spatters.  
如果使用助焊剂，完成焊接后一定要清除剩余的助焊剂（除非卤化物助焊剂）。建议焊接时用盖子保护显示屏面以避免因助焊剂溅出造成的任何损坏。
2. When soldering the OLED module and PC board, the panel and board should not be detached more than three times. This maximum number is determined by the temperature and time conditions mentioned above, though there may be some variance depending on the temperature of the soldering iron.  
焊接 OLED 模块和线路板时，不应装卸多于三次。尽管焊接温度会有变化，但不应超过上面提到的焊接温度和时间最大值。
3. When remove the OLED module from the PC board, be sure the solder has completely melted, the soldered pad on the PC board could be damaged.  
从线路板上移除 OLED 模块时，要保证焊锡已完全熔化，不要损坏线路板上的焊接位。

#### ◆ Precautions for Operation (工作运行注意事项)

1. OLED is a self-light device, do not use back character on a white background display mode, otherwise the power consumption will be higher and it will cause crosstalk.  
OLED 是自发光器件，不要使用白底黑字显示模式，否则功耗增大，并且会有交叉效应。
2. It is an indispensable condition to drive OLED's within the specified voltage limit since the higher voltage than the limit will damage the driver IC.  
在 OLED 驱动电压内来操作模块是必要的。超过限定电压会损坏集成电路。
3. The brightness will be lower at lower temperature than the normal temperature and will be higher at higher temperature. However those phenomena do not mean malfunction or out of order with OLED's, which will come back in the normal temperature.  
OLED 亮度在低温时比常温要暗，高温时，会比常温要高。然而,这并不是指 OLED 示屏工作异常，显示屏在恢复常温时，效果会恢复正常。
4. If the display area is pushed hard, the display will cause pixel short, it will become the display defect.  
如果在运行过程中显示区受到挤压,将可能引起像素短路，引起显示缺陷。
5. A slight dew depositing on terminals is a cause for electro-chemical reaction resulting in terminal open circuit. Usage under the maximum operating temperature, 50%RH or less is required.  
接线端冷凝会引起电化学反应而断路。因此必须在最大的操作温度之内，湿度小于 50% 的条件下使用 OLED 模块。
6. Input logic voltage before apply analog high voltage such as OLED driving voltage when power on. Remove analog high voltage before logic voltage when power off the module. Input each signal after the positive/negative voltage becomes stable.  
开机时，先接通逻辑电压，再接通模拟高压，比如 OLED 驱动电压。关机时，先断开模拟高压，再关逻辑电压。正负电源都稳定后再送控制信号。
7. Please keep the temperature within the specified range for use and storage. Polarization degradation, bubble generation or polarizer peel-off may occur with high temperature and high humidity.  
模块在操作和存储规格范围内使用。高温高湿可能会引起偏振退化，起泡，偏光片脱落等问题。

#### ◆ Safety (安全)

1. It is recommended to crush damaged or unnecessary OLED into pieces.  
建议将损坏的 OLED 显示屏压成碎片。
2. If any solid or powder leaks out of a damaged glass cell and comes in contact with the hands, wash off thoroughly with soap and water.  
如果任何固体或粉末从玻璃种泄漏出且与手接触,要用肥皂和水彻底清洗。

### ◆ Limited Warranty (有限质保)

Unless agreed between TRULY and the customer, TRULY will replace or repair any of its OLED modules which are found to be functionally defective when inspected in accordance with TRULY OLED acceptance standards (copies available upon request) for a period of one year from date of production. Cosmetic/visual defects must be returned to TRULY within 90 days of shipment. Confirmation of such date shall be based on data code on product. The warranty liability of TRULY limited to repair and/or replace on the terms set forth above. TRULY will not be responsible for any subsequent or consequential events.

除信利和客户之间另有协议外，自生产之日起一年内，根据信利的OLED显示屏品质标准，信利将对有功能缺陷的OLED显示模块换货或返工。外观/视觉缺陷产品，必须在出货后90天内归还信利。以产品上标识日期为准。信利保修责任仅限于对符合上述规定的货品进行返工和/或换货。对此后发生的任何情况，信利均不承担任何责任。

### ◆ Return OLED Module under Warranty (OLED 模块返修质保)

1. No warranty can be granted if the precautions stated above have been disregarded. The typical examples of violations are :

保修是以上述注意事项未被忽视为先决条件的。典型的违反例子如下：

- Broken OLED glass.

-断裂的 OLED 显示屏玻璃。

- PCB eyelet is damaged or modified.

-印制线路板孔修改或损坏。

-PCB conductors damaged.

-线路板导体损坏。

- Circuit modified in any way, including addition of components.

-线路随意变更，包括元件变化。

- PCB tampered with by grinding, engraving or painting varnish.

-印制电路板已修改，如研磨，雕刻，绘涂等。

- Soldering to or modifying the bezel in any manner.

-焊接或变动模块

2. Module repairs will be invoiced to the customer upon mutual agreement. Modules must be returned with sufficient description of the failures or defects. Any connectors or cable installed by the customer must be removed completely without damaging the PCB eyelet, conductors and terminals.

模块维修清单将按双方协议送呈客户。模块详细缺陷描述须模块一并退回。顾客安装的连接器和电缆必须在不破坏线路板孔，线路和引线端条件下全部移去。

## ■ PRIOR CONSULT MATTER（提前商议事项）

1. For Truly standard products, we keep the right to change material, process ... for improving the product property without prior notice to our customer.  
对于信利的标准产品，我们保留在不通知客户的情况下,为提高产品性能而改变原材料及加工方法等的权利。
2. For OEM products, if any changes are needed which may affect the product property, we will consult with our customer in advance.  
对于 OEM 产品，如果需要做任何会影响到产品性能的改变，我们会提前和客户商议。
3. If you have special requirement about reliability condition, please let us know before you start the test on our samples.  
如对可靠性条件有特殊要求，请在产品测试前通知我们。