

Wibbow

Wireless SGWPT800P

Pressure Sensor

Compatible with LoraWAN Protocol



The wireless pressure sensor achieves pressure acquisition and utilizes the LoraWAN transmission protocol to realize wireless data collection, transmission, and monitoring. It is embedded with certain intelligent diagnostic algorithms, enabling self-diagnosis. This sensor is suitable for pressure monitoring of industrial equipment.

Product Size: $\phi 50\text{mm} \times 108.5\text{mm}$ ().

Materials of Enclosure: Metal Parts: 304 Stainless Steel(inlet pressure head);
Plastic Parts: PC(Orange Enclosure).

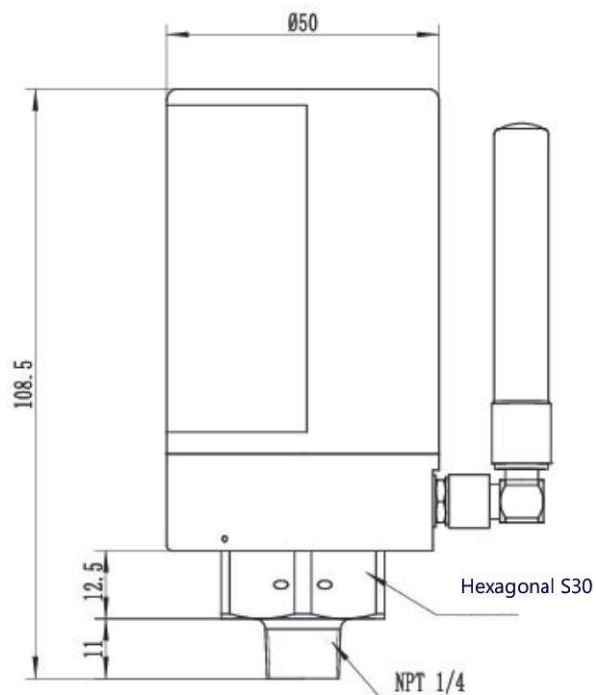

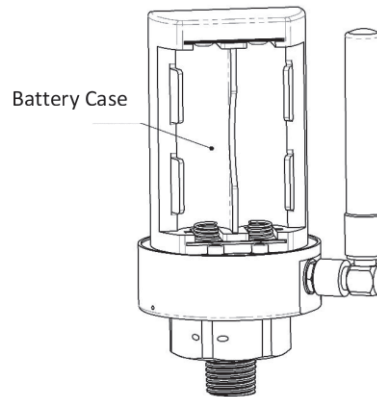
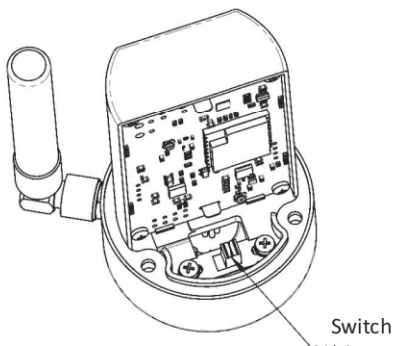

Open the enclosure, then you will see the switch ():

Switch : It employs a mechanical switch. Sliding this switch left or right can control the circuit's on/off state.

Electrical Connection ():

The top is the positive pole, and the bottom is the negative pole. It can accommodate two AA batteries inserted in the same orientation.

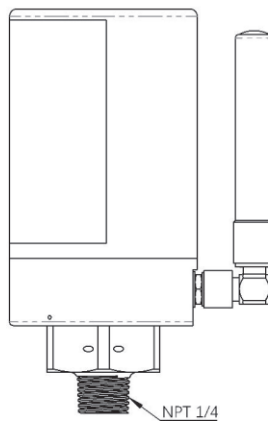

It is tightened and fixed through the NPT 1/4 threaded connection at the bottom, and the safety hole is provided for installing a fuse to prevent loosening, see .

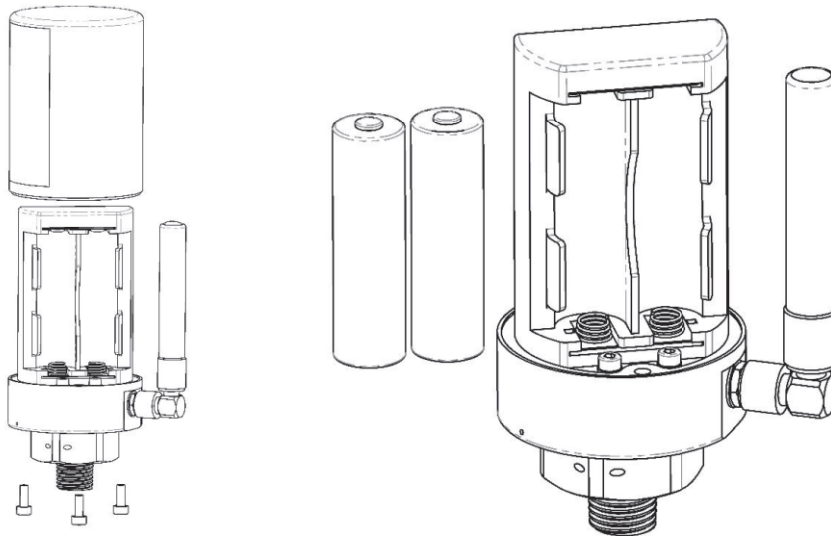

See

- (1) Unscrewing the three screws to remove the the outer casing;
- (2) Insert two AA batteries into the battery compartment with the positive end facing up and the negative end facing down, in the same orientation.

Wireless pressure sensors have been applied in various fields such as industrial monitoring, hydrological monitoring, petrochemicals, environmental protection, water supply pipe network supervision, reservoir level monitoring, power station inspections and locomotive braking systems. This information is quite extensive and can serve as the foundation for industrial automation and infrastructure monitoring.

Production Process Monitoring:

- Used in industries such as petroleum, chemicals, metallurgy and pharmaceuticals to monitor the fluid pressure in reactors and pipelines, ensuring production safety and stability.
- Monitors equipment pressure in food processing to ensure that the process flow conforms to standards.

Equipment Operation Status Monitoring:

- Real-time monitoring of pressure changes in equipment such as compressors and pumps to predict maintenance needs and reduce the risk of downtime.

Energy Sector:

- **Oil and Gas Industry:** Monitoring wellheads and pipeline pressures and optimize extraction and transportation efficiency 35.

-
- **Electricity Industry:** Utilized for power station inspections and hydraulic system pressure monitoring to ensure the safe operation of equipment 15.
 - **Wind Power Sector:** Monitoring hydraulic systems, gearbox lubricating oil pressure, and blade root pressure to prevent equipment failures 5.
- Environmental Protection Monitoring
- **Air Pollution Monitoring:** Analyzing the dispersion of pollutants.
 - **Wastewater Treatment:** Real-time monitoring of pipeline pressure to ensure treatment effectiveness.

- **Multi-protocol Compatibility:** Supports a variety of communication protocols such as NB-IoT, LoRaWAN, CLAA, LinkWAN and GPRS, adapting to networking needs in different scenarios 25.
- **Integrated Bluetooth Functionality:** Allows for parameter configuration and data viewing through a mobile phone APP.

- **Ultra-low Standby Current.**
- **Standby current** $\leq 50 \mu A$, paired with a high-capacity rechargeable lithium battery of 19000mAh.
- **Utilizes solar charging** to achieve ultra-long battery life spanning several years.
- **Implements a sleep-wake mechanism** and energy-saving algorithms to further reduce energy consumption.

- **Cloud Platform Integration:** Supports seamless integration with cloud management platforms, enabling remote storage, historical querying, and visual analysis of pressure data, as well as the generation of customized reports.
- **Mobile Control:** Offers a mobile app(such as MultiGage), supporting real-time data viewing, alarm threshold setting, and device status monitoring, compatible with iOS, Android, and Windows systems.

- **Remote Parameter Setting:** Allows for remote adjustment of parameters such as sampling interval, data upload frequency, and trigger alarm values via the cloud or app, eliminating the need for on-site operations.
- **Firmware Online Upgrade:** Supports remote software upgrade functionality, ensuring continuous optimization and expansion of device capabilities.

- **Dynamic Alarm System:** Supports active alarms for overpressure and underpressure conditions, with customizable alarm methods (such as SMS, email, or platform push notifications) to enhance the efficiency of response to anomalies.

➤ Data Resend and Redundancy: Automatically caches data during network interruptions and immediately resends it upon reconnection to ensure data integrity.

The wireless pressure sensor adopts an intrinsically safe design, supporting hazardous locations in Zone 0.

- Zone 0, Category IIC gas environment, ExialICT4

Number	Category	Indicator	Note
1	Measurement Range	0~10Mpa (Optional)	Gauge pressure
2	Operating Temperature	-40°C ~85°C	
3	Measured Medium	Oxygen, Helium, Nitrogen and Kerosene (in gaseous and liquid states)	
4	Total Measurement Accuracy	≤±1%FS	Full temperature range
5	Normal Accuracy	≤±0.5%FS	Normal temperature
6	Overload Pressure	1.5 times the full scale	
7	Safety Pressure	2 times the full scale	
8	Leak Rate	≤1×10 ⁻⁷ Pa*m ³ /s (mandatory inspection point)	
9	Power Supply Voltage	Battery-powered	
10	Power Consumption	During sleep mode <60uA	
		Data acquisition and transmission <160mA	
11	Battery Life	3-5 years	
12	Transmission Frequency	Once every 10 minutes	
13	Interface Type	Wireless Lora	
14	Communication Band	915MHz	
15	Transmission Power	≥11.5dBm	
16	Operating Range	2.5km	
17	Receiver Sensitivity	-100dBm	
18	Transmission Rate	50kbps	Adjustment during design
19	Weight	<500g	
20	Waterproof Rating	IP66	