

PROPRIETARY NOTE

THIS SPECIFICATION IS THE PROPERTY OF BOE BJ AND SHALL NOT BE REPRODUCED OR COPIED WITHOUT THE WRITTEN PERMISSION OF BOE BJ AND MUST BE RETURNED TO BOE BJ UPON ITS REQUEST



SPEC. NUMBER

PRODUCT GROUP

REV.

ISSUE DATE

PAGE

S8-64-8A-247

DID

P2

2020.06.10

1 OF 35

DV980QUM-N10 Product Specification Rev.P1

Fuzhou BOE Optoelectronics CO., LTD

PROPRIETARY NOTE

THIS SPECIFICATION IS THE PROPERTY OF BOE BJ AND SHALL NOT BE REPRODUCED OR COPIED WITHOUT THE WRITTEN PERMISSION OF BOE BJ AND MUST BE RETURNED TO BOE BJ UPON ITS REQUEST



SPEC. NUMBER
S8-64-8A-247

PRODUCT GROUP
DID

REV.
P2

ISSUE DATE
2020.06.10

PAGE
2 OF 35

REVISION HISTORY

() Preliminary specification

() Final specification

Revision No.	Page	Description of changes	Date	Prepared
P0	-	Initial Release	2020/03/31	Enlong.Wu
P1	5	Power Consumption	2020/04/30	Enlong.Wu
P2	4	Local Dimming Description	2020/06/10	Peng.Li

PROPRIETARY NOTE

THIS SPECIFICATION IS THE PROPERTY OF BOE BJ AND SHALL NOT BE REPRODUCED OR COPIED WITHOUT THE WRITTEN PERMISSION OF BOE BJ AND MUST BE RETURNED TO BOE BJ UPON ITS REQUEST



SPEC. NUMBER

PRODUCT GROUP

REV.

ISSUE DATE

PAGE

S8-64-8A-247

DID

P2

2020.06.10

3 OF 35

Contents

No	ITEM	Page
	REVISIONS HISTORY	2
	CONTENTS	3
1	GENERAL DESCRIPTION	4
	1.1 Introduction	
	1.2 Features	
	1.3 Applications	
	1.4 General Specification	
2	ABSOLUTE MAXIMUM RATINGS	6
3	ELECTRICAL SPECIFICATIONS	7
	3.1 Open Cell Electrical Specifications	
	3.2 Converter Electrical Specifications	
4	INTERFACE CONNECTION	9
	4.1 Open Cell Input Signal & Power	
	4.2 BLU Input Signal & Power	
	4.3 VBO Interface	
5	SIGNAL TIMING SPECIFICATIONS	15
	5.1 Timing Parameters	
	5.2 Vx1 Input Signal Timing	
	5.3 Input Signals, Basic Display Colors and Gray Scale of Colors	
	5.4 Power Sequence	
6	OPTICAL SPECIFICATIONS	19
7	MECHANICAL CHARACTERISTICS	21
8	RELIABILITY	22
9	PRODUCT SERIAL NUMBER	23
10	PACKING INFORMATION	24
11	PRECAUTIONS	26
12	APPENDIX	31

PROPRIETARY NOTE

THIS SPECIFICATION IS THE PROPERTY OF BOE BJ AND SHALL NOT BE REPRODUCED OR COPIED WITHOUT THE WRITTEN PERMISSION OF BOE BJ AND MUST BE RETURNED TO BOE BJ UPON ITS REQUEST

BOE

SPEC. NUMBER

S8-64-8A-247

PRODUCT GROUP

DID

REV.

P2

ISSUE DATE

2020.06.10

PAGE

4 OF 35

1.0 GENERAL DESCRIPTION

1.1 Introduction

DV980QUM-N10 a color active matrix TFT LCD open cell using amorphous silicon TFT's (Thin Film Transistors) as an active switching devices. This OC has a 98 inch diagonally measured active area with resolutions (3840 horizontal by 2160 vertical pixel array). Each pixel is divided into RED, GREEN, BLUE dots which are arranged in vertical stripe and this OC can display 1.07G colors. The TFT-LCD panel used for this OC is adapted for a low reflection and higher color type.

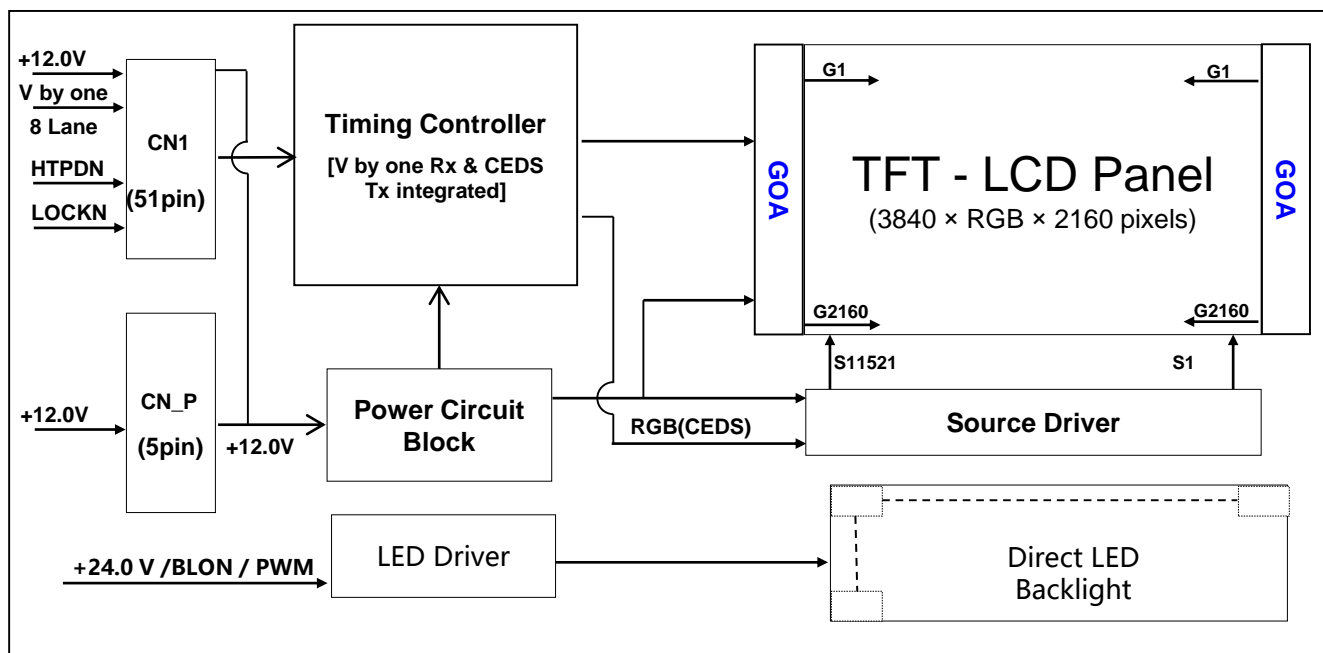

1.2 Features

- V by one interface with 8 lanes
- High-speed response
- Low color shift image quality
- 8-bit + FRC color depth, display 1.07G colors
- High luminance and contrast ratio, low reflection and wide viewing angle
- GOA mode
- ADS technology is applied for high display quality
- RoHS compliant
- Supports Local Dimming, block number : 224

PROPRIETARY NOTE

THIS SPECIFICATION IS THE PROPERTY OF BOE BJ AND SHALL NOT BE REPRODUCED OR COPIED WITHOUT THE WRITTEN PERMISSION OF BOE BJ AND MUST BE RETURNED TO BOE BJ UPON ITS REQUEST



SPEC. NUMBER
S8-64-8A-247

PRODUCT GROUP
DID

REV.
P2

ISSUE DATE
2020.06.10

PAGE
5 OF 35

1.3 Application

- Display Terminals for Control System
- Ultra High Definition Public Monitor

1.4 General Specification

< Table 1. General Specifications >

Parameter	Specification	Unit	Remark
MDL Outline	2187.8(H)X 1242.8(V)	mm	
Active area	2158.848(H)X 1214.352(V)	mm	
Number of pixels	3840(H) ×2160(V)	pixels	
Pixel pitch	562.2(H) ×562.2(V)	μm	
Pixel arrangement	1G1D, Z Inversion, 2T1C GOA		
Display colors	1.07G (8bits+FRC)	colors	
Display mode	Normally Black		
Brightness	500(Typ.)	nit	Center point
MDL Thickness	33.2mm	mm	Body
Weight	61,000(Typ.)	gram	
Power Consumption	253*2 =506W(Max.)	Watt	Note 1
Surface Treatment	AG25/Clear(CF /TFT POL)		
Life time	50000	Hrs	Note 2
Remark	7*24Hrs Continuous Operation Horizontal and Perpendicular Compatibility		

Note 1: Total power consumption = $P_{DD} * 2$.

BLU power efficiency is calculated as 85% , $P_{BLU} = P_{DD} * 2 * 85\%$

Note 2: The life time is determined as the time which luminance of LED is 50% compare to the initial value at the typical LED current on condition of continuous operating in LCM state at $25 \pm 2 \text{ } ^\circ\text{C}$

PROPRIETARY NOTE

THIS SPECIFICATION IS THE PROPERTY OF BOE BJ AND SHALL NOT BE REPRODUCED OR COPIED WITHOUT THE WRITTEN PERMISSION OF BOE BJ AND MUST BE RETURNED TO BOE BJ UPON ITS REQUEST



SPEC. NUMBER S8-64-8A-247	PRODUCT GROUP DID	REV. P2	ISSUE DATE 2020.06.10	PAGE 6 OF 35
------------------------------	----------------------	------------	--------------------------	-----------------

2.0 ABSOLUTE MAXIMUM RATINGS

The followings are maximum values which, if exceed, may cause faulty operation or damage to the unit. The operational and non-operational maximum voltage and current values are listed in Table 2.

< Table 2. Open Cell Electrical Specifications >

[VSS=GND=0V]

Parameter	Symbol	Min.	Max.	Unit	Remark
Power Supply Voltage	VDD	VSS-0.3	13.5	V	Ta = 25 °C
Operating Temperature	T _{OP}	0	+50	°C	Note 1
Storage Temperature	T _{SUR}	-20	+60	°C	
	T _{ST}	-20	+60	°C	
Operating Ambient Humidity	Hop	10	90	%RH	
Storage Humidity	Hst	10	90	%RH	
Panel Surface Temperature	PST	-	65	°C	Note 2

Note 1 : Temperature and relative humidity range are shown in the figure below.

Wet bulb temperature should be 39 °C max. and no condensation of water.

Note 2 : Surface temperature is measure at 50°C Dry condition

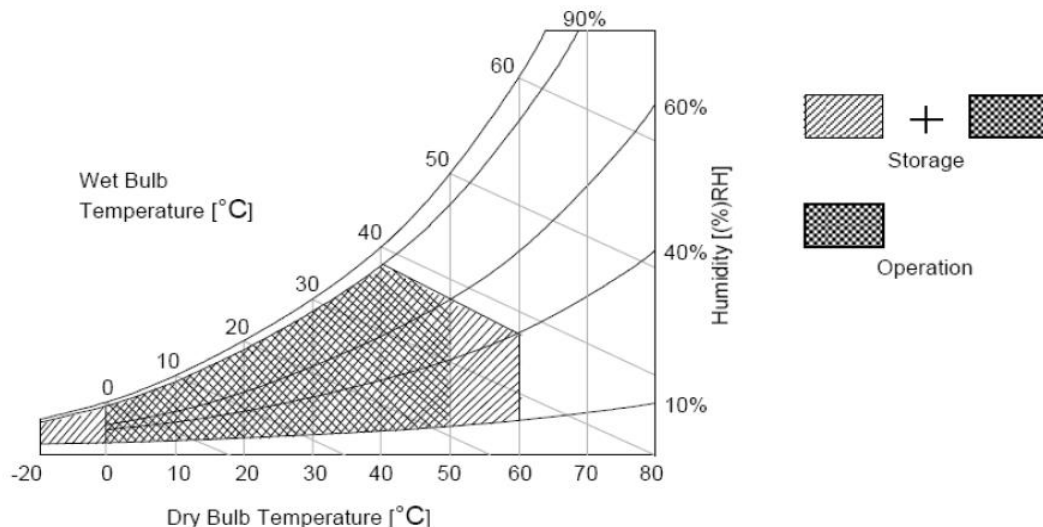

PROPRIETARY NOTE

THIS SPECIFICATION IS THE PROPERTY OF BOE BJ AND SHALL NOT BE REPRODUCED OR COPIED WITHOUT THE WRITTEN PERMISSION OF BOE BJ AND MUST BE RETURNED TO BOE BJ UPON ITS REQUEST



SPEC. NUMBER S8-64-8A-247	PRODUCT GROUP DID	REV. P2	ISSUE DATE 2020.06.10	PAGE 7 OF 35
------------------------------	----------------------	------------	--------------------------	-----------------

3.0 ELECTRICAL SPECIFICATIONS

3.1 TFT LCD Open Cell

< Table 3. Open Cell Electrical Specifications >

[Ta =25±2 °C]

Parameter		Symbol	Values			Unit	Remark
			Min	Typ	Max		
Power Supply Input Voltage		VDD	10.8	12	13.2	Vdc	
Power Supply Ripple Voltage		VRP	-	-	600	mV	
Power Supply Current		IDD	-	1400	3600	mA	Note 1
Power Consumption		PDD	-	16.8	38	Watt	
Rush current		IRUSH	-	-	4	A	Note 2
V by One Interface	Differential Input High Threshold Voltage	VLVTH	-	-	+50	mV	-
	Differential Input Low Threshold Voltage	VLVTL	-50	-	-	mV	-
	Common Input Voltage	VLVC	-	0	-	V	-
	Terminating Resistor	Rt	80	100	120	ohm	-
CMOS Interface	Input High Threshold Voltage	VIH	2.7	-	3.3	V	
	Input Low Threshold Voltage	VIL	0	-	0.6	V	

Note 1 : The supply voltage is measured and specified at the interface connector of LCM.

The current draw and power consumption specified is for VDD=12.0V,

Frame rate $f_v=60\text{Hz}$ and Clock frequency = 74.25MHz.

Test Pattern of power supply current

Note 2 : The duration of rush current is about 2ms and rising time of Power Input is 0.5ms(min)

a) Typ : Mosaic 7X5 (L0/L255)

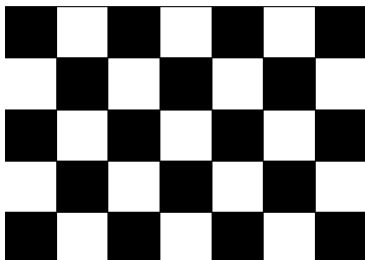

b) Max : Horizontal 1 Line (L0/L255)



c) Flicker Test Pattern

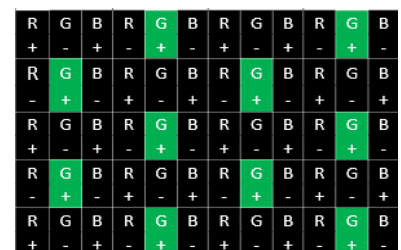

PROPRIETARY NOTE

THIS SPECIFICATION IS THE PROPERTY OF BOE BJ AND SHALL NOT BE REPRODUCED OR COPIED WITHOUT THE WRITTEN PERMISSION OF BOE BJ AND MUST BE RETURNED TO BOE BJ UPON ITS REQUEST

BOE

SPEC. NUMBER
S8-64-8A-247

PRODUCT GROUP
DID

REV.
P2

ISSUE DATE
2020.06.10

PAGE
8 OF 35

3.2 Converter Electrical Specifications

< Table 4. Converter Electrical Specifications >

[Ta =25±2 °C]

Parameter	Symbol	Values			Unit	Remark
		Min	Typ	Max		
Power Supply Input Voltage	V _{BL}	21.6	24	26.4	Vdc	
Power Supply Ripple Voltage	V _{RP}	-	-	300	mV	
Power Supply Current	I _{DD}	-	10.1	10.6	A	
Power Consumption	P _{DD}	-	242	253	Watt	Note 1
Backlight On/Off Control Voltage	V _{BLON} (off)	0	-	0.3	V	
	V _{BLON} (on)	2.4	3.3	3.6	V	
Backlight PWM	High Level	2.4	3.3	3.6	V	On duty
	Low Level	0	-	0.3	V	Off duty
	Dimming Ratio	1	-	100	%	Note 2
	PWM Frequency	100	-	300	Hz	

Note 1: The specified current and power consumption are under the typical supply input voltage, 24V.

It is power consumption for each board. Total power consumption = P_{DD}*2.

BLU power efficiency is calculated as 85%, P_{BLU} = P_{DD}*2*85%

Note 2 : High-duty = On/(On+Off) * 100

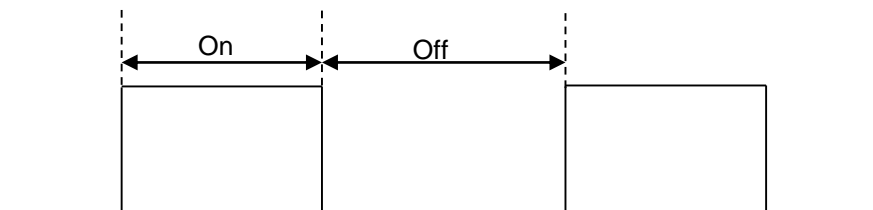

PROPRIETARY NOTE

THIS SPECIFICATION IS THE PROPERTY OF BOE BJ AND SHALL NOT BE REPRODUCED OR COPIED WITHOUT THE WRITTEN PERMISSION OF BOE BJ AND MUST BE RETURNED TO BOE BJ UPON ITS REQUEST



SPEC. NUMBER

PRODUCT GROUP

REV.

ISSUE DATE

PAGE

S8-648D-106

DID

P2

2020.06.10

9 OF 35

3.0 ELECTRICAL SPECIFICATIONS

3.2 TCON Characteristics

< Table 4. TCON Characteristics >

Parameter	Symbol	Values			Unit	Remark
		Min	Typ	Max		
TCON Surface Temperature	T_{TS}	-	-	95	°C	Note

Note 1 : Any point on the TCON surface must be less than 104 °C under any conditions.

Note 2 : This test condition is based on BOE module.

3.3 Driver Characteristics

< Table 5. Driver Characteristics >

Parameter	Symbol	Values			Unit	Remark
		Min	Typ	Max		
Driver Surface Temperature	T_{DS}	-	-	110	°C	Note

Note 3 : Any point on the driver surface must be less than 110 °C under any conditions.

Note 4: This test condition is based on BOE module.

3.4 PMIC Characteristics

< Table 6. PMIC Characteristics >

Parameter	Symbol	Values			Unit	Remark
		Min	Typ	Max		
PMIC Surface Temperature	T_{PS}	-	-	110	°C	Note

Note 5 : Any point on the PMIC surface must be less than 110 °C under any conditions.

Note 6: This test condition is based on BOE module.

PROPRIETARY NOTE

THIS SPECIFICATION IS THE PROPERTY OF BOE BJ AND SHALL NOT BE REPRODUCED OR COPIED WITHOUT THE WRITTEN PERMISSION OF BOE BJ AND MUST BE RETURNED TO BOE BJ UPON ITS REQUEST



SPEC. NUMBER S8648D106 S8648A127	PRODUCT GROUP DID	REV. P2	ISSUE DATE 2020.06.10	PAGE 10 OF 35
--	----------------------	------------	--------------------------	------------------

3.0 ELECTRICAL SPECIFICATIONS

3.5 VCOM I2C Bus Format

Slave Address

Bit7	Bit6	Bit 5	Bit 4	Bit 3	Bit 2	Bit 1	Bit 0 = LSB
0	1	0	0	0	0	0	R/ \bar{W}

Write Command

(a) Write single byte of data to Register

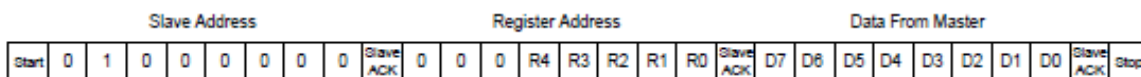

(b) Write multiple bytes of data to Registers

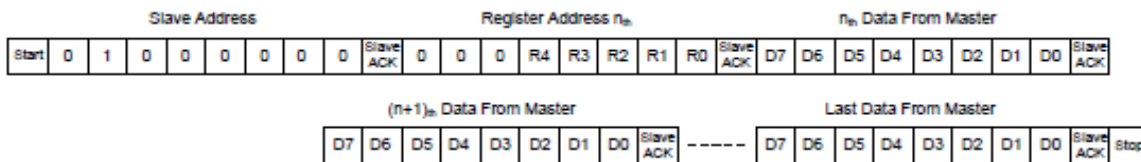

(c) Write All Registers into EEPROM

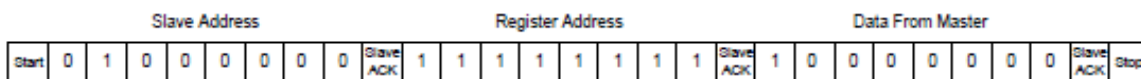

(d) Write VCOM data Registers into EEPROM

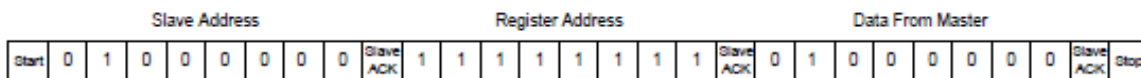

Read Command

(a) Read single byte of data from Register

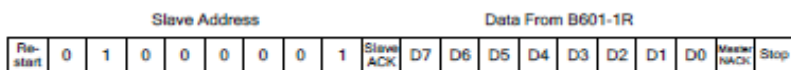
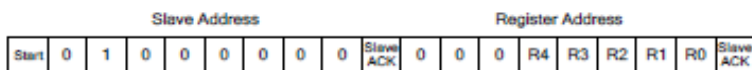
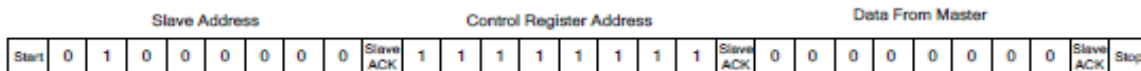

PROPRIETARY NOTE

THIS SPECIFICATION IS THE PROPERTY OF BOE BJ AND SHALL NOT BE REPRODUCED OR COPIED WITHOUT THE WRITTEN PERMISSION OF BOE BJ AND MUST BE RETURNED TO BOE BJ UPON ITS REQUEST



SPEC. NUMBER S8648D106 S8648A147	PRODUCT GROUP DID	REV. P2	ISSUE DATE 2020.06.10	PAGE 11 OF 35
--	----------------------	------------	--------------------------	------------------

3.0 ELECTRICAL SPECIFICATIONS

3.5 VCOM I2C Bus Format

(b) Read multiple bytes of data from Registers

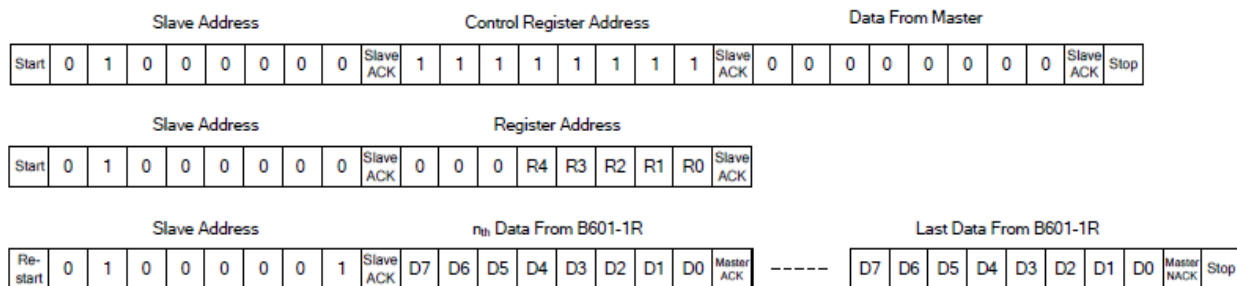

(c) Read data from EEPROM

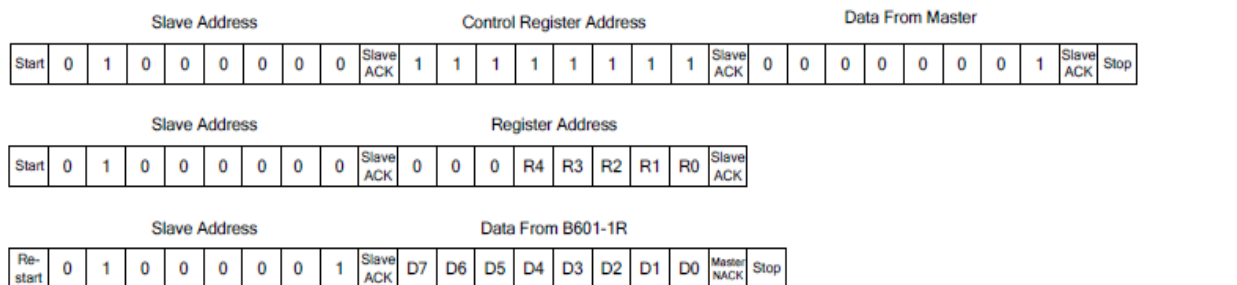

(d) Read multiple bytes of data from EEPROM

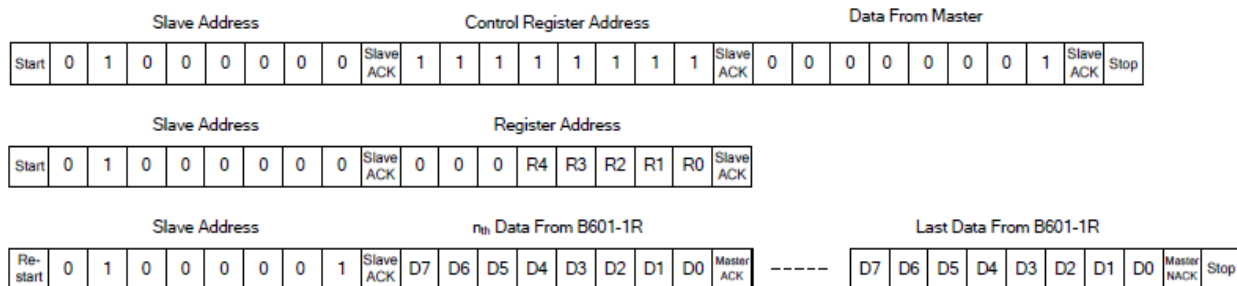

PROPRIETARY NOTE

THIS SPECIFICATION IS THE PROPERTY OF BOE BJ AND SHALL NOT BE REPRODUCED OR COPIED WITHOUT THE WRITTEN PERMISSION OF BOE BJ AND MUST BE RETURNED TO BOE BJ UPON ITS REQUEST



SPEC. NUMBER
S8-64-8A-247

PRODUCT GROUP
DID

REV.
P2

ISSUE DATE
2020.06.10

PAGE
12 OF 35

4.0 INTERFACE CONNECTION

4.1 Open Cell Input Signal & Power

- V by one Connector : F05035-51P-H(Changtong) or **PM.FPC.LVS0505101(UJC)**.

- < Table 5. Open Cell Input Connector Pin Configuration >

Pin No	Symbol	Description	Pin No	Symbol	Description
1	VDD	Power Supply +12.0V	27	GND	Ground
2	VDD	Power Supply +12.0V	28	Rx0n	V-by-One HS Data Lane 0
3	VDD	Power Supply +12.0V	29	Rx0p	V-by-One HS Data Lane 0
4	VDD	Power Supply +12.0V	30	GND	Ground
5	VDD	Power Supply +12.0V	31	Rx1n	V-by-One HS Data Lane 1
6	VDD	Power Supply +12.0V	32	Rx1p	V-by-One HS Data Lane 1
7	VDD	Power Supply +12.0V	33	GND	Ground
8	VDD	Power Supply +12.0V	34	Rx2n	V-by-One HS Data Lane 2
9	NC	No Connection	35	Rx2p	V-by-One HS Data Lane 2
10	GND	Ground	36	GND	Ground
11	GND	Ground	37	Rx3n	V-by-One HS Data Lane 3
12	GND	Ground	38	Rx3p	V-by-One HS Data Lane 3
13	GND	Ground	39	GND	Ground
14	GND	Ground	40	Rx4n	V-by-One HS Data Lane 4
15	NC	No Connection	41	Rx4p	V-by-One HS Data Lane 4
16	NC	No Connection	42	GND	Ground
17	NC	No Connection	43	Rx5n	V-by-One HS Data Lane 5
18	SDA	SDA(For I2C)	44	Rx5p	V-by-One HS Data Lane 5
19	SCL	SCL(For I2C)	45	GND	Ground
20	NC	No Connection	46	Rx6n	V-by-One HS Data Lane 6
21	Aging (BIST)	H : Enable (Default) L : Disable	47	Rx6p	V-by-One HS Data Lane 6
22	SEL_SECTI ON	H : 2 Section L : 1 Section (Default)	48	GND	Ground
23	NC	No Connection	49	Rx7n	V-by-One HS Data Lane 7
24	GND	Ground	50	Rx7p	V-by-One HS Data Lane 7
25	HTPDN	Hot Plug Detect	51	GND	Ground
26	LOCKN	Lock Detect			

Notes : 1. NC (Not Connected) : This pins are only used for BOE internal operations.

2.BIST : This pin is used for selecting display pattern mode when input DE or input CLOCK quits toggling.

Rear view of LCM

BIST Pattern

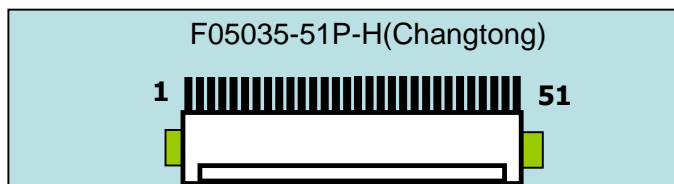

PT1: Black (2 sec)	PT2: White (2 sec)	PT3: Red (2 sec)	PT4: Green (2 sec)	PT5: Blue (2 sec)

PROPRIETARY NOTE

THIS SPECIFICATION IS THE PROPERTY OF BOE BJ AND SHALL NOT BE REPRODUCED OR COPIED WITHOUT THE WRITTEN PERMISSION OF BOE BJ AND MUST BE RETURNED TO BOE BJ UPON ITS REQUEST



SPEC. NUMBER

PRODUCT GROUP

REV.

ISSUE DATE

PAGE

S8-64-8A-247

DID

P2

2020.06.10

13 OF 35

4.2 BLU Input Signal & Power

4.2.1 Master Converter Interface

- BLU Connector(CN1 & CN2) : CI0114M1HR0-NH (Cvilux)or Equivalent.

< Table 6. Input Connector Pin Configuration CN1&CN2>

Pin No	Symbol	Description	Pin No	Symbol	Description
1	V _{BL}	Operating Voltage Supply, +24V DC regulated	8	GND	Ground and Current Return
2	V _{BL}	Operating Voltage Supply, +24V DC regulated	9	GND	Ground and Current Return
3	V _{BL}	Operating Voltage Supply, +24V DC regulated	10	GND	Ground and Current Return
4	V _{BL}	Operating Voltage Supply, +24V DC regulated	11	NC	No Connection
5	V _{BL}	Operating Voltage Supply, +24V DC regulated	12	BLON	BLU On-Off control: DC 0 to 0.8V off, DC 2.4 to 5.25V On
6	GND	Ground and Current Return	13	PWM	0V:Min, 3.3V:Max
7	GND	Ground and Current Return	14	NC	No Connection

PROPRIETARY NOTE

THIS SPECIFICATION IS THE PROPERTY OF BOE BJ AND SHALL NOT BE REPRODUCED OR COPIED WITHOUT THE WRITTEN PERMISSION OF BOE BJ AND MUST BE RETURNED TO BOE BJ UPON ITS REQUEST



SPEC. NUMBER

PRODUCT GROUP

REV.

ISSUE DATE

PAGE

S8-64-8A-247

DID

P2

2020.06.10

14 OF 35

4.2.2 Slave Converter Interface

- BLU Connector(CN1 & CN2) : CI0114M1HR0-NH (Cvilux)or Equivalent.

< Table 7. Input Connector Pin Configuration CN1&CN2>

Pin No	Symbol	Description	Pin No	Symbol	Description
1	VBL	Operating Voltage Supply, +24V DC regulated	8	GND	Ground and Current Return
2	VBL	Operating Voltage Supply, +24V DC regulated	9	GND	Ground and Current Return
3	VBL	Operating Voltage Supply, +24V DC regulated	10	GND	Ground and Current Return
4	VBL	Operating Voltage Supply, +24V DC regulated	11	NC	No Connection
5	VBL	Operating Voltage Supply, +24V DC regulated	12	BLON	BLU On-Off control: DC 0 to 0.8V off, DC 2.4 to 5.25V On
6	GND	Ground and Current Return	13	PWM	0V:Min, 3.3V:Max
7	GND	Ground and Current Return	14	NC	No Connection

PROPRIETARY NOTE

THIS SPECIFICATION IS THE PROPERTY OF BOE BJ AND SHALL NOT BE REPRODUCED OR COPIED WITHOUT THE WRITTEN PERMISSION OF BOE BJ AND MUST BE RETURNED TO BOE BJ UPON ITS REQUEST



SPEC. NUMBER

PRODUCT GROUP

REV.

ISSUE DATE

PAGE

S8-64-8A-247

DID

P2

2020.06.10

15 OF 35

4.3 VBO Interface

- VBO Receiver : Timing Controller (VBO Rx merged)

< Table 8. Input Connector Pin Configuration >

Byte	Packer input	Color data mapping
		30 bpp RGB
0	Bit-0	R2
	Bit-1	R3
	Bit-2	R4
	Bit-3	R5
	Bit-4	R6
	Bit-5	R7
	Bit-6	R8
	Bit-7	R9
1	Bit-8	G2
	Bit-9	G3
	Bit-10	G4
	Bit-11	G5
	Bit-12	G6
	Bit-13	G7
	Bit-14	G8
	Bit-15	G9
2	Bit-16	B2
	Bit-17	B3
	Bit-18	B4
	Bit-19	B5
	Bit-20	B6
	Bit-21	B7
	Bit-22	B8
	Bit-23	B9
3	Bit-24	-
	Bit-25	-
	Bit-26	B0
	Bit-27	B1
	Bit-28	G0
	Bit-29	G1
	Bit-30	R0
	Bit-31	R1

PROPRIETARY NOTE

THIS SPECIFICATION IS THE PROPERTY OF BOE BJ AND SHALL NOT BE REPRODUCED OR COPIED WITHOUT THE WRITTEN PERMISSION OF BOE BJ AND MUST BE RETURNED TO BOE BJ UPON ITS REQUEST



SPEC. NUMBER

PRODUCT GROUP

REV.

ISSUE DATE

PAGE

S8-64-8A-247

DID

P2

2020.06.10

16 OF 35

5.0 SIGNAL TIMING SPECIFICATION**5.1 Timing Parameters (DE only mode)**

< Table 9. Timing Table >

Item		Symbols	Min	Typ	Max	Unit
Frequency		1/Tc	68.24	74.25	79.97	MHz
Vertical	Frame Rate	F	58	60	61	Hz
	Total	T _V	2220	2250	2300	T _H
	Display	T _{VD}	2160			T _H
	Blank	T _{VB}	60	90	140	T _H
Horizontal	Total	T _H	530	550	570	T _{CLK}
	Display	T _{HD}	-	480	-	T _{CLK}
	Blank	T _{HB}	50	70	90	T _{CLK}

PROPRIETARY NOTE

THIS SPECIFICATION IS THE PROPERTY OF BOE BJ AND SHALL NOT BE REPRODUCED OR COPIED WITHOUT THE WRITTEN PERMISSION OF BOE BJ AND MUST BE RETURNED TO BOE BJ UPON ITS REQUEST



SPEC. NUMBER S8-64-8A-247	PRODUCT GROUP DID	REV. P2	ISSUE DATE 2020.06.10	PAGE 17 OF 35
------------------------------	----------------------	------------	--------------------------	------------------

5.2 Vx1 Input Signal Timing

< Table 10. Signal Timing Waveforms Table >

Parameter	Symbol	Condition	Min	Typ	Max	Unit
Unit Interval(VBO Operation Bit Rate)	tRBIT	3-byte	380	tTCIP/30	1667	PS
		4-byte	285	tTCIP/40	1250	PS
		5-byte	266	tTCIP/50	1000	PS
Eye Width at Package Pin	tREYE	-	-	0.5	-	UI
Eye Width Position A at Package Pin	tA	-	-	0.25	-	UI
Eye Width Position B at Package Pin	tB	-	-	0.3	-	UI
Eye Width Position Cat Package Pin	tC	-	-	0.7	-	UI
Eye Width Position D at Package Pin	tD	-	-	0.75	-	UI
Eye Width Position E at Package Pin	tE	-	-	0.7	-	UI
Eye Width Position F at Package Pin	tF	-	-	0.3	-	UI
Intra – pair Skew	TTOSK_intra	-	-	-	0.3	UI
Inter – pair Skew	TTOSK_inter	-	-	-	40	UI
SSCG						%

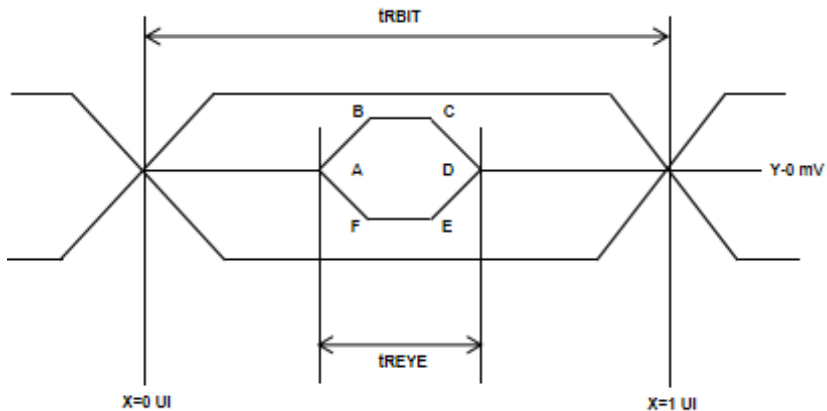

	Y[mV]
A	0
B	50
C	50
D	0
E	-50
F	-50

PROPRIETARY NOTE

THIS SPECIFICATION IS THE PROPERTY OF BOE BJ AND SHALL NOT BE REPRODUCED OR COPIED WITHOUT THE WRITTEN PERMISSION OF BOE BJ AND MUST BE RETURNED TO BOE BJ UPON ITS REQUEST



SPEC. NUMBER
S8-64-8A-247

PRODUCT GROUP
DID

REV.
P2

ISSUE DATE
2020.06.10

PAGE
19 OF 35

5.4 Power Sequence

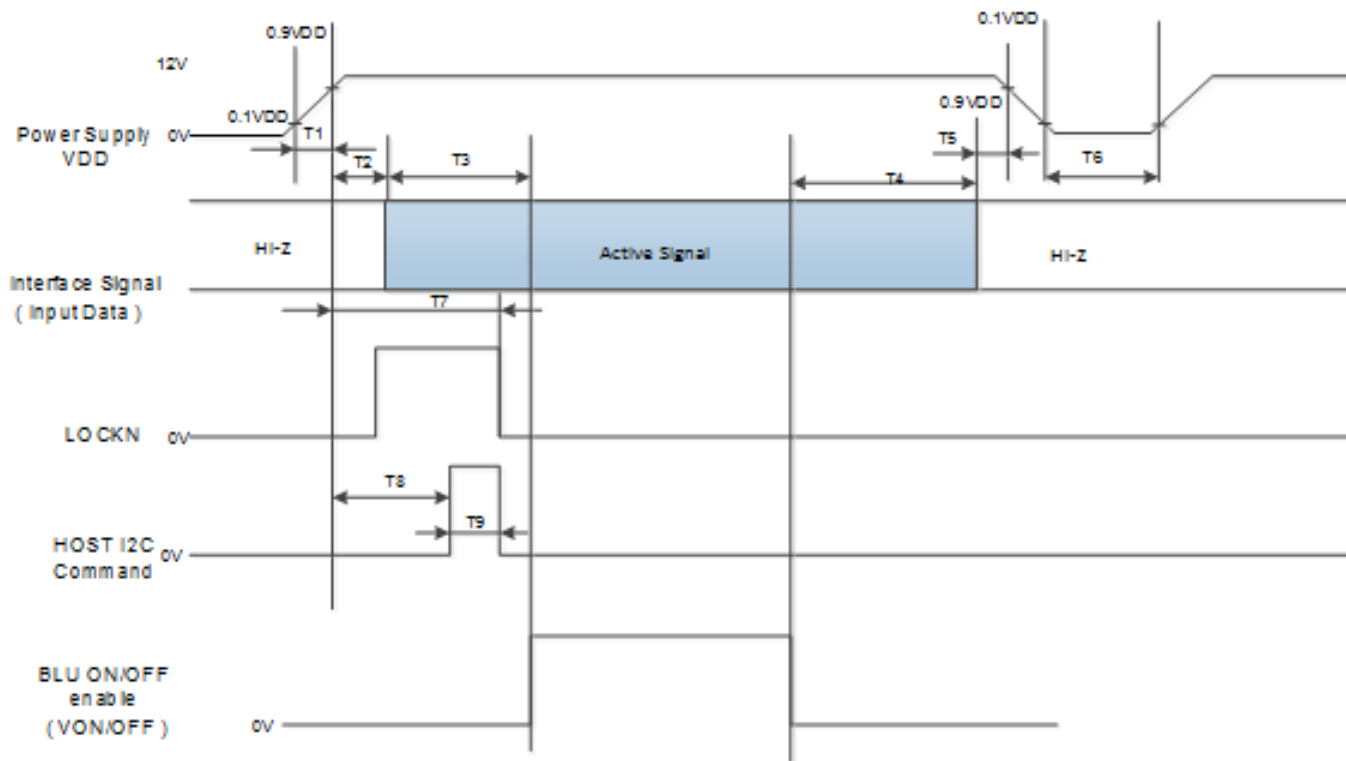

< Table 12. Sequence Table >

Parameter	Values			Units
	Min	Typ	Max	
T1	0.5	-	10	ms
T2	0	-	-	ms
T3	200	-	-	ms
T4	100	-	-	ms
T5	0	-	50	ms
T8	1	-	-	s
T7	200	-	-	ms
T8	0	-	1200	ms
T9	Depends on I2C command			ms

- Notes: 1. Even though T1 is over the specified value, there is no problem if I2T spec of fuse is satisfied.
2. Back Light must be turn on after power for logic and interface signal are valid.

PROPRIETARY NOTE

THIS SPECIFICATION IS THE PROPERTY OF BOE BJ AND SHALL NOT BE REPRODUCED OR COPIED WITHOUT THE WRITTEN PERMISSION OF BOE BJ AND MUST BE RETURNED TO BOE BJ UPON ITS REQUEST



SPEC. NUMBER S8-64-8A-247	PRODUCT GROUP DID	REV. P2	ISSUE DATE 2020.06.10	PAGE 20 OF 35
------------------------------	----------------------	------------	--------------------------	------------------

6.0 OPTICAL SPECIFICATIONS

The test of optical specifications shall be measured in a dark room (ambient luminance \leq 1 lux and temperature $=25\pm 2^{\circ}\text{C}$) with the equipment of Luminance meter system (Goniometer system and PR730) and test unit shall be located at an approximate distance 50cm from the LCD surface at a viewing angle of θ and Φ equal to 0° . We refer to $\theta_{\phi=0}$ ($=\theta_3$) as the 3 o'clock direction (the "right"), $\theta_{\phi=90}$ ($=\theta_{12}$) as the 12 o'clock direction ("upward"), $\theta_{\phi=180}$ ($=\theta_9$) as the 9 o'clock direction ("left") and $\theta_{\phi=270}$ ($=\theta_6$) as the 6 o'clock direction ("bottom"). While scanning θ and/or ϕ , the center of the measuring spot on the Display surface shall stay fixed. The measurement shall be executed after 30 minutes warm-up period. VDD shall be 12.0V +/-10% at 25°C . Optimum viewing angle direction is 6 'clock.

< Table 13. Optical Table >

[VDD = 12.0V, Frame rate = 60Hz, Ta = $25\pm 2^{\circ}\text{C}$]

Parameter		Symbol	Condition	Min	Typ	Max	Unit	Remark
Viewing Angle	Horizontal	Θ_3	CR > 10		89		Deg.	Note 1
		Θ_9			89		Deg.	
	Vertical	Θ_{12}			89		Deg.	
		Θ_6			89		Deg.	
Contrast ratio		CR		900:1	1200:1	-		Note 2
Chromaticity coordinate	White	W_x	$\Theta = 0^{\circ}$ (Center) Normal Viewing Angle	TYP. - 0.03	0.28	TYP. + 0.03		Note 3
		W_y			0.29			
	Red	R_x			0.652			
		R_y			0.339			
	Green	G_x			0.312			
		G_y			0.624			
	Blue	B_x			0.153			
		B_y			0.054			
Response Time	G to G	T_g		-	8	10	ms	Note 4
Color Gamut				-	72	-	%	NTSC
Gamma Scale				2.0	2.2	2.4		
Color Temp				8000	10000	12000	K	
Brightness				400	500		nit	
Uniformity				75			%	Note 5

PROPRIETARY NOTE

THIS SPECIFICATION IS THE PROPERTY OF BOE BJ AND SHALL NOT BE REPRODUCED OR COPIED WITHOUT THE WRITTEN PERMISSION OF BOE BJ AND MUST BE RETURNED TO BOE BJ UPON ITS REQUEST



SPEC. NUMBER S8-64-8A-247	PRODUCT GROUP DID	REV. P2	ISSUE DATE 2020.06.10	PAGE 21 OF 35
------------------------------	----------------------	------------	--------------------------	------------------

Notes :

- Viewing angle is the angle at which the contrast ratio is greater than 10. The viewing are determined for the horizontal or 3, 9 o' clock direction and the vertical or 6, 12 o' clock direction with respect to the optical axis which is normal to the LCD surface.
- Contrast measurements shall be made at viewing angle of $\theta = 0^\circ$ and at the center of the LCD surface. Luminance shall be measured with all pixels in the view field set first to white, then to the dark (black) state. (See Figure 1 shown in Appendix) Luminance Contrast Ratio (CR) is defined mathematically.

$$CR = \frac{\text{Luminance when displaying a white raster}}{\text{Luminance when displaying a black raster}}$$

- The color chromaticity coordinates specified in Table 14 .shall be calculated from the spectral data measured with all pixels first in red, green, blue and white. Measurements shall be made at the center of the panel.
- Response time Tg is the average time required for display transition by switching the input signal as below table and is based on Frame rate fV =60Hz to optimize. Each ti me in below table is defined as Figure2 and shall be measured by switching the input signal;

Measured Response Time	Target																
	0	15	31	47	63	79	95	111	127	143	159	175	191	207	223	239	255
Start																	
0																	
15																	
31																	
47																	
63																	
79																	
95																	
111																	
127																	
143																	
159																	
175																	
191																	
207																	
223																	
239																	
255																	

- Brightness Uniformity measurement shall be taken at the locations shown in Figure 3.

PROPRIETARY NOTE

THIS SPECIFICATION IS THE PROPERTY OF BOE BJ AND SHALL NOT BE REPRODUCED OR COPIED WITHOUT THE WRITTEN PERMISSION OF BOE BJ AND MUST BE RETURNED TO BOE BJ UPON ITS REQUEST



SPEC. NUMBER

PRODUCT GROUP

REV.

ISSUE DATE

PAGE

S8-64-8A-247

DID

P2

2020.06.10

22 OF 35

7.0 MECHANICAL CHARACTERISTICS

7.1 Dimensional Requirements

Table 15 provides general mechanical characteristics.
Other parameters are shown in Figure 4、 Figure 5.

< Table 14. Dimensional Parameters >

Parameter	Specification	Unit
MDL Outline	2187.8(H)X 1242.8(V)	mm
Active area	2158.848(H)X 1214.352(V)	mm
MDL Thickness	33.2 (Body)	mm
Weight	61000(Typ.)	gram

7.2 Surface treatment

The surface of the LCD has an Anti-glare coating to minimize reflection and a coating to Reduce scratching.

PROPRIETARY NOTE

THIS SPECIFICATION IS THE PROPERTY OF BOE BJ AND SHALL NOT BE REPRODUCED OR COPIED WITHOUT THE WRITTEN PERMISSION OF BOE BJ AND MUST BE RETURNED TO BOE BJ UPON ITS REQUEST



SPEC. NUMBER
S8-64-8A-247

PRODUCT GROUP
DID

REV.
P2

ISSUE DATE
2020.06.10

PAGE
23 OF 35

8.0 RELIABILITY TEST

The Reliability test items and its conditions are shown in below.

< Table 15. Reliability Test Parameters >

No	Test Items	Conditions
1	High temperature storage test	Ta = 60 °C, 240 hrs
2	Low temperature storage test	Ta = -20 °C, 240 hrs
3	High temperature & high humidity operation test	Ta = 50 °C, 80%RH, 240hrs
4	Low temperature operation test	Ta =0 °C, 240hrs
5	High temperature operation test	Ta =50 °C, 240hrs
6	Vibration test (non-operating)	Frequency : 5~ 200 Hz, Random Gravity / AMP : 1.05Grms Period : +Z
7	Electro-static discharge test	Air : ±15kV ,150pF/330Ω ,100Point ,1time/Point MDL Contact :±8kV ,150pF/330Ω ,100Point , 1time/Point Pin Contact:±5KV, 150pF/330Ω, Input connector Pin, 3 times/pin with no function loss

PROPRIETARY NOTE

THIS SPECIFICATION IS THE PROPERTY OF BOE BJ AND SHALL NOT BE REPRODUCED OR COPIED WITHOUT THE WRITTEN PERMISSION OF BOE BJ AND MUST BE RETURNED TO BOE BJ UPON ITS REQUEST



SPEC. NUMBER S8-64-8A-247	PRODUCT GROUP DID	REV. P2	ISSUE DATE 2020.06.10	PAGE 24 OF 35
------------------------------	----------------------	------------	--------------------------	------------------

9.0 PRODCUT SERIAL NUMBER

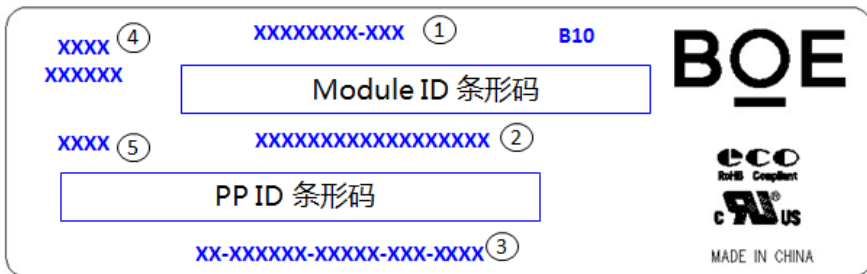

- ① FG-CODE
- ② Module ID, 最后一位为Revision Code (扫描不显示), 前17位编码规则如下
- ③ PPID (客户端ID)
- ④ D/PN码, 规格待确定
- ⑤ 生产年份+生产周别 (中间无空格)

MDL ID Naming Rule:

Digit	1	2	3	4	5	6	7	8	9	10	11	12	13	14	15	16	17
Code	S	L	S	A	1	0	8	5	9	4	2	0	0	0	1	D	B
Description	Product Code/GBN→FG-CODE—一对应		Grade	line	Year	Month	Model Extension Code (Last 4 Digits of FG-CODE)				Serial No. Hex-Decimal 000000-FFFFFF						

PROPRIETARY NOTE

THIS SPECIFICATION IS THE PROPERTY OF BOE BJ AND SHALL NOT BE REPRODUCED OR COPIED WITHOUT THE WRITTEN PERMISSION OF BOE BJ AND MUST BE RETURNED TO BOE BJ UPON ITS REQUEST



SPEC. NUMBER
S8-64-8A-247

PRODUCT GROUP
DID

REV.
P2

ISSUE DATE
2020.06.10

PAGE
25 OF 35

10.0 PACKING INFORMATION

BOE provides the standard shipping container for customers, unless customer specifies their packing information. The standard packing method and Barcode information are shown in below.

10.1 Packing Order

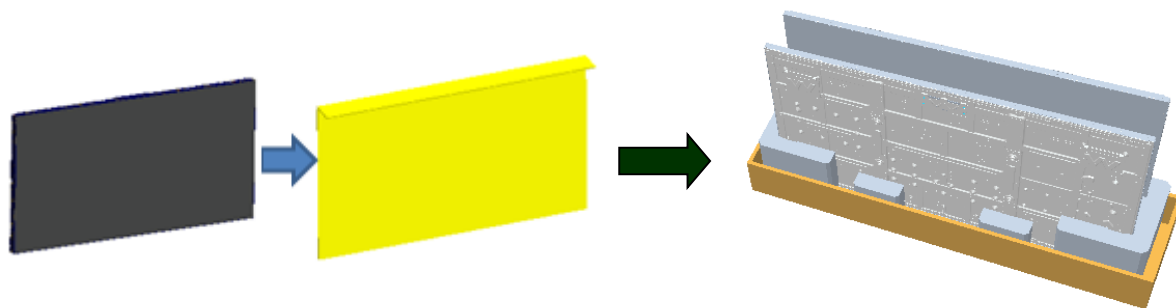

Put one Pcs into the PE Bag

Put Two Pcs LCD MDL in the EPE With Carton BOX.

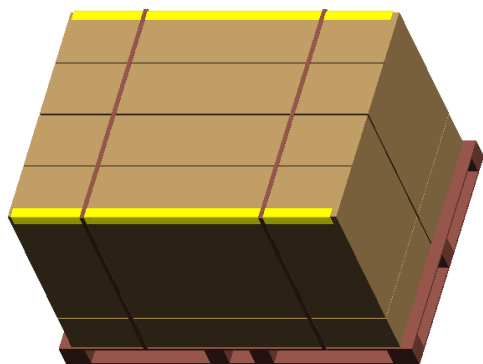

Put the Top-cover on the Box (4ea MDLs per pallet) and Pack with 2 packing belts.

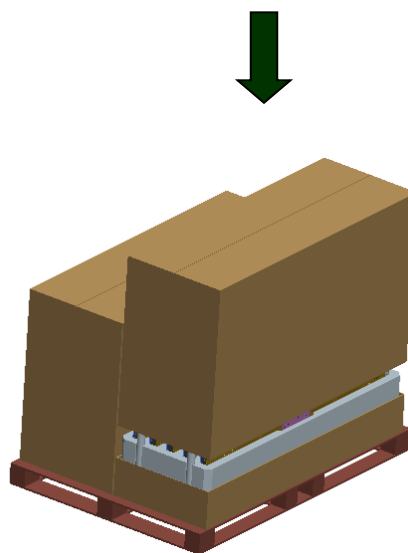

Put 2 EPE BOX on the pallet.

PROPRIETARY NOTE

THIS SPECIFICATION IS THE PROPERTY OF BOE BJ AND SHALL NOT BE REPRODUCED OR COPIED WITHOUT THE WRITTEN PERMISSION OF BOE BJ AND MUST BE RETURNED TO BOE BJ UPON ITS REQUEST



SPEC. NUMBER S8-64-8A-247	PRODUCT GROUP DID	REV. P2	ISSUE DATE 2020.06.10	PAGE 26 OF 35
------------------------------	----------------------	------------	--------------------------	------------------

10.2 Packing Note

- Box Dimension : 2424mm (L) × 554mm (W) × 1375mm (H)
- Package Quantity in one Box : 2pcs

10.3 Box Label

- Label Size : 100 mm (L) × 50 mm (W)
- Contents

Model : UV980QUB-N10

Q`ty : Module 2 Q`ty in one box

Serial No. : Box Serial No. See next page for detail description.

Date : Packing Date

FG Code : FG Code of Product

BOE
FUZHOU BOE OPTOELECTRONICS
TECHNOLOGY Co.,LTD

MODEL: XXXXXXXX-XXX ① Q'TY: XXX ②

SERIAL NO: XXXXXXXXXXXXXX③ DATE: XXXX.XX.XX ④

Box ID 条形码

XXXXXXXXXXXXXX ⑤ XXXX ⑥

打印内容, 说明如下:

- ① FG-CODE
- ② 产品数量
- ③ Box ID, 编码规则如下
- ④ Box Packing 日期
- ⑤ 产品物料号(客户端)
- ⑥ FG-CODE 后四位

Digit Code	1	2	3	4	5	6	7	8	9	10	11	12	13
Code	X	X	X	X	1	6	3	D	0	0	1	A	1
Descripti on	Products G BN		Gra de	Line	Year		Mon th	Revisi on Code	Serial No.				

PROPRIETARY NOTE

THIS SPECIFICATION IS THE PROPERTY OF BOE BJ AND SHALL NOT BE REPRODUCED OR COPIED WITHOUT THE WRITTEN PERMISSION OF BOE BJ AND MUST BE RETURNED TO BOE BJ UPON ITS REQUEST

BOE

SPEC. NUMBER

PRODUCT GROUP

REV.

ISSUE DATE

PAGE

S8-64-8A-247

DID

P2

2020.06.10

27 OF 35

11.0 PRECAUTIONS

Please pay attention to the followings when you use this TFT LCD Module.

11.1 Mounting Precautions

- Use finger-stalls with soft gloves in order to keep display clean during the incoming inspection and assembly process.
- You must mount a module using specified mounting holes (Details refer to the drawings).
- You should consider the mounting structure so that uneven force (ex. Twisted stress, Concentrated stress) is not applied to the module. And the case on which a module is mounted should have sufficient strength so that external force is not transmitted directly to the module.
- Do not apply mechanical stress or static pressure on module; Abnormal display cause by pressing some parts of module during assembly process, do not belong to product failure, the press should be agreed by two sides.
- Determine the optimum mounting angle, refer to the viewing angle range in the specification for each model.
- You should adopt radiation structure to satisfy the temperature specification.
- Acetic acid type and chlorine type materials for the cover case are not desirable because the former generates corrosive gas of attacking the polarizer at high temperature and the latter causes circuit break by electro-chemical reaction.
- Do not touch, push or rub the exposed polarizers with glass, tweezers or anything harder than HB pencil lead. And please do not rub with dust clothes with chemical treatment.
- Do not touch the surface of polarizer for bare hand or greasy cloth. (Some cosmetics are detrimental to the polarizer.)
- When the surface becomes dusty, please wipe gently with absorbent cotton or other soft materials like chamois soaks with petroleum benzine. Normal-hexane & alcohol is recommended for cleaning the adhesives used to attach front / rear polarizers. Do not use acetone, toluene, because they cause chemical damage to the polarizer.
- Wipe off saliva or water drops as soon as possible. Their long time contact with polarizer causes deformations and color fading.
- Do not apply static pressure on module, and avoid impact, vibration and falling.
- This module has its circuitry PCB's on the rear side and Driver IC, should be handled carefully in order not to be stressed.
- Avoid impose stress on PCB and Driver IC during assembly process, Do not drawing, bending, COF package & wire
- Do not disassemble the module.

PROPRIETARY NOTE

THIS SPECIFICATION IS THE PROPERTY OF BOE BJ AND SHALL NOT BE REPRODUCED OR COPIED WITHOUT THE WRITTEN PERMISSION OF BOE BJ AND MUST BE RETURNED TO BOE BJ UPON ITS REQUEST



SPEC. NUMBER	PRODUCT GROUP	REV.	ISSUE DATE	PAGE
S8-64-8A-247	DID	P2	2020.06.10	28 OF 35

11.2 Operating Precautions

- Do not connector or disconnect the cable to/from the Module at the "Power On" Condition.
- When the module is operating, do not lose CLK, ENAB signals. If any one of these signals is lost, the module would be damaged.
- Obey the supply voltage sequence. If wrong sequence is applied, the module would be damaged.
- The electrochemical reaction caused by DC voltage will lead to LCD module degradation, so DC drive should be avoided.
- The LCD modules use C-MOS LSI drivers, so customers are recommended that any unused input terminal would be connected to Vdd or Vss, do not input any signals before power is turn on, and ground you body, work/assembly area, assembly equipment to protect against static electricity.
- Do not exceed the absolute maximum rating value. (supply voltage variation, input voltage variation, variation in part contents and environmental temperature, and so on) Otherwise the Module may be damaged.
- Module has high frequency circuits. Sufficient suppression to the electromagnetic interference shall be done by system manufacturers. Grounding and shielding methods may be important to minimized the interference.
- Design the length of cable to connect between the connector for back-light and the converter as shorter as possible and the shorter cable shall be connected directly , The long cable between back-light and Converter may cause the Luminance of LED to lower and need a higher startup voltage
- The cables should be as short as possible between System Board and PCB interface.
- Connectors are precision devices to transmit electrical signals, and operators should plug in parallel
- Be careful for condensation at sudden temperature change. Condensation makes damage to polarizer or electrical contacted parts. And after fading condensation, smear or spot will occur.

11.3 Electrostatic Discharge Precautions

- Since a module is composed of electronic circuits, it is not strong to electrostatic discharge. Make certain that treatment persons are connected to ground through wrist band etc.
- Do not touch interface pin directly.

PROPRIETARY NOTE

THIS SPECIFICATION IS THE PROPERTY OF BOE BJ AND SHALL NOT BE REPRODUCED OR COPIED WITHOUT THE WRITTEN PERMISSION OF BOE BJ AND MUST BE RETURNED TO BOE BJ UPON ITS REQUEST



SPEC. NUMBER

PRODUCT GROUP

REV.

ISSUE DATE

PAGE

S8-64-8A-247

DID

P2

2020.06.10

29 OF 35

11.4 Precautions for Strong Light Exposure

- Do not leave the module operation or storage in Strong light . Strong light exposure causes degradation of polarizer and color filter.

11.5 Precautions for Storage

A. Atmosphere Requirement

ITEM	UNIT	MIN	MAX
Storage Temperature	(°C)	5	40
Storage Humidity	(%rH)	35	75
Storage Life	6 months		
Storage Condition	<ul style="list-style-type: none"> • The storage room should be equipped with a dark and good ventilation facility. • Prevent products from being exposed to the direct sunlight, moisture and water. • The product need to keep away from organic solvent and corrosive gas. • Be careful for condensation at sudden temperature change. • Storage condition is guaranteed under packing conditions. 		

B. Package Requirement

- The product should be placed in a sealed polythene bag.
- Product Should be placed on the pallet, Which is away from the floor, Be cautions not to pile the product up.
- As the original protective film, do not use the adhesive protective film to avoid change of Pol color and characteristic.

11.6 Precautions for protection film

- Remove the protective film slowly, keeping the removing direction approximate 30-degree not vertical from panel surface, If possible, under ESD control device like ion blower, and the humidity of working room should be kept over 50%RH to reduce the risk of static charge.
- People who peeled off the protection film should wear anti-static strap and grounded well.

PROPRIETARY NOTE

THIS SPECIFICATION IS THE PROPERTY OF BOE BJ AND SHALL NOT BE REPRODUCED OR COPIED WITHOUT THE WRITTEN PERMISSION OF BOE BJ AND MUST BE RETURNED TO BOE BJ UPON ITS REQUEST



SPEC. NUMBER	PRODUCT GROUP	REV.	ISSUE DATE	PAGE
S8-64-8A-247	DID	P2	2020.06.10	30 OF 35

11.7 Appropriate Condition for Commercial Display

- Generally large-sized LCD modules are designed for consumer applications . Accordingly, long-term display like in Commercial Display application, can cause uneven display including image sticking. To optimize module's lifetime and function, several operating usages are required.

1. Normal operating condition

- Temperature: $20\pm 15^{\circ}\text{C}$
- Operating Ambient Humidity : $55\pm 20\%$
- Display pattern: dynamic pattern (Real display)

2. Special operating condition

a. Ambient condition

- Well-ventilated place is recommended to set up Commercial Display system.

b. Power and screen save

- Periodical power-off or screen save is needed after long-term display.

c. As the low temperature, the response time is greatly delayed. As the high temperatures (higher than the operating temperature) the LCD module may turn black screen. The above phenomenon cannot explain the failure of the display. When the temperature returns to the normal operating temperature, the LCD module will return to normal display.

d. When expose to drastic fluctuation of temperature (hot to cold or cold to hot) ,the LCD module may be affected; Specifically, drastic temperature fluctuation from cold to hot ,produces dew on the LCD module 's surface which may affect the operation of the polarizer and LCD module

e. Do not exceed the absolute maximum rating value. (supply voltage variation, input voltage variation, variation in part contents and environmental temperature, and so on) Otherwise the Module may be damaged.

f. Product reliability and functions are only guaranteed when the product is used under right operation usages. If product will be used in extreme conditions such as high temperature, high humidity, high altitude, special display images, running time, long time operation, outdoor operation, etc. It is strongly recommended to contact BOE for filed application engineering advice. Otherwise, its reliability and function may not be guaranteed. Extreme conditions are commonly found at airports, transit stations, banks, stock market and controlling systems.

PROPRIETARY NOTE

THIS SPECIFICATION IS THE PROPERTY OF BOE BJ AND SHALL NOT BE REPRODUCED OR COPIED WITHOUT THE WRITTEN PERMISSION OF BOE BJ AND MUST BE RETURNED TO BOE BJ UPON ITS REQUEST



SPEC. NUMBER

PRODUCT GROUP

REV.

ISSUE DATE

PAGE

S8-64-8A-247

DID

P2

2020.06.10

31 OF 35

3. Operating usages to protect against image sticking due to long-term static display.

a. Suitable operating time: under 24 hours a day.

(The moving picture can be allowed for 24 hours a day)

b. Static information display recommended to use with moving image.

- Cycling display between 5 minutes' information(static) display and 10 seconds' moving image.

c. Background and character (image) color change

- Use different colors for background and character, respectively.

- Change colors themselves periodically.

d. Avoid combination of background and character with large different luminance.

- Abnormal condition just means conditions except normal condition.

- Black image or moving image is strongly recommended as a screen save

4. Lifetime in this spec. is guaranteed only when Commercial Display is used according to operating usages.

5. Module should be turned clockwise based on front view when used in portrait mode.

11.8 Other Precautions

A. LC Leak

- If the liquid crystal material leaks from the panel, it is recommended to wash the LC with acetone or ethanol and then burn it.
- In case of contact with hands, skin or clothes, it has to be washed away thoroughly with soap.
- If LC in mouth, mouth need to be washed, drink plenty of water to induce vomiting and follow medical advice.
- If LC touch eyes, eyes need to be washed with running water at least 15 minutes.

B. Rework

- When returning the module for repair or etc., Please pack the module not to be broken. We recommend to use the original shipping packages.

PROPRIETARY NOTE

THIS SPECIFICATION IS THE PROPERTY OF BOE BJ AND SHALL NOT BE REPRODUCED OR COPIED WITHOUT THE WRITTEN PERMISSION OF BOE BJ AND MUST BE RETURNED TO BOE BJ UPON ITS REQUEST



SPEC. NUMBER S8-64-8A-247	PRODUCT GROUP DID	REV. P2	ISSUE DATE 2020.06.10	PAGE 32 OF 35
------------------------------	----------------------	------------	--------------------------	------------------

12.0 APPENDIX

< Figure 1. Measurement Set Up >

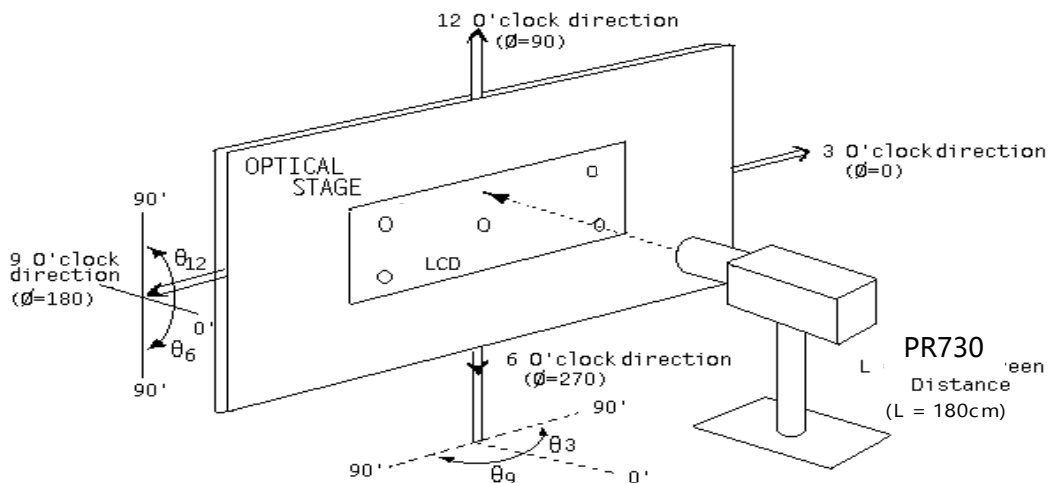

< Figure 2. Response Time Testing >

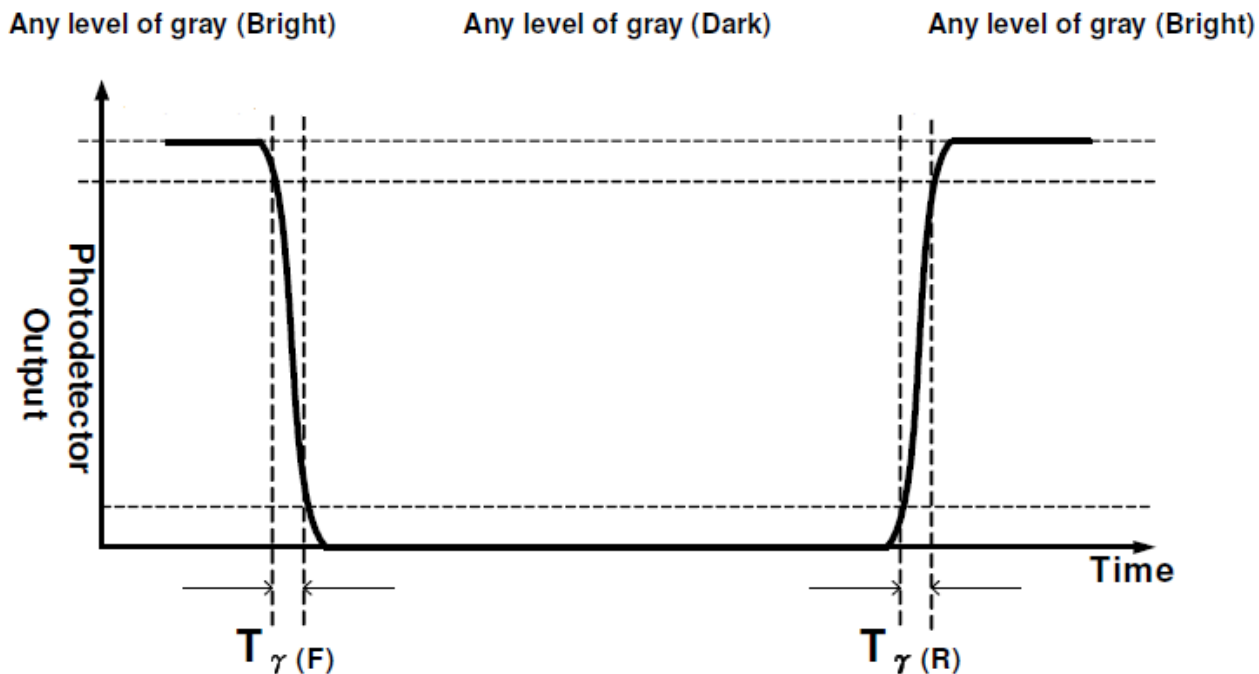

PROPRIETARY NOTE

THIS SPECIFICATION IS THE PROPERTY OF BOE BJ AND SHALL NOT BE REPRODUCED OR COPIED WITHOUT THE WRITTEN PERMISSION OF BOE BJ AND MUST BE RETURNED TO BOE BJ UPON ITS REQUEST



SPEC. NUMBER

PRODUCT GROUP

REV.

ISSUE DATE

PAGE

S8-64-8A-247

DID

P2

2020.06.10

33 OF 35

12.0 APPENDIX

< Figure 3. Uniformity Measurement Locations >

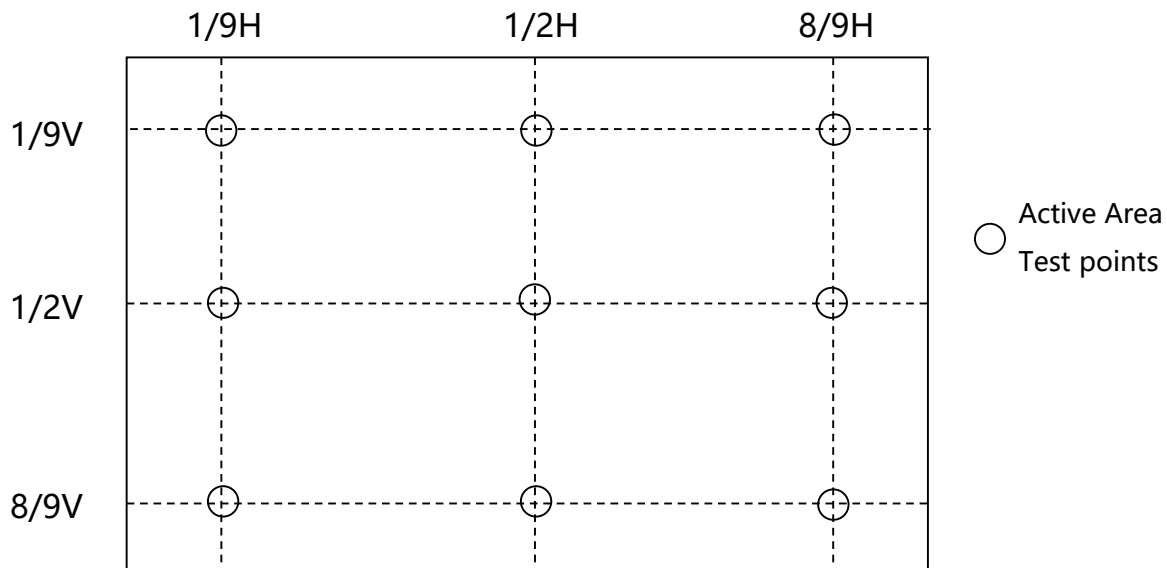

PROPRIETARY NOTE

THIS SPECIFICATION IS THE PROPERTY OF BOE BJ AND SHALL NOT BE REPRODUCED OR COPIED WITHOUT THE WRITTEN PERMISSION OF BOE BJ AND MUST BE RETURNED TO BOE BJ UPON ITS REQUEST



SPEC. NUMBER

PRODUCT GROUP

REV.

ISSUE DATE

PAGE

S8-64-8A-247

DID

P2

2020.06.10

34 OF 35

Figure 4. TFT-LCD Module Outline Dimensions (Front view)

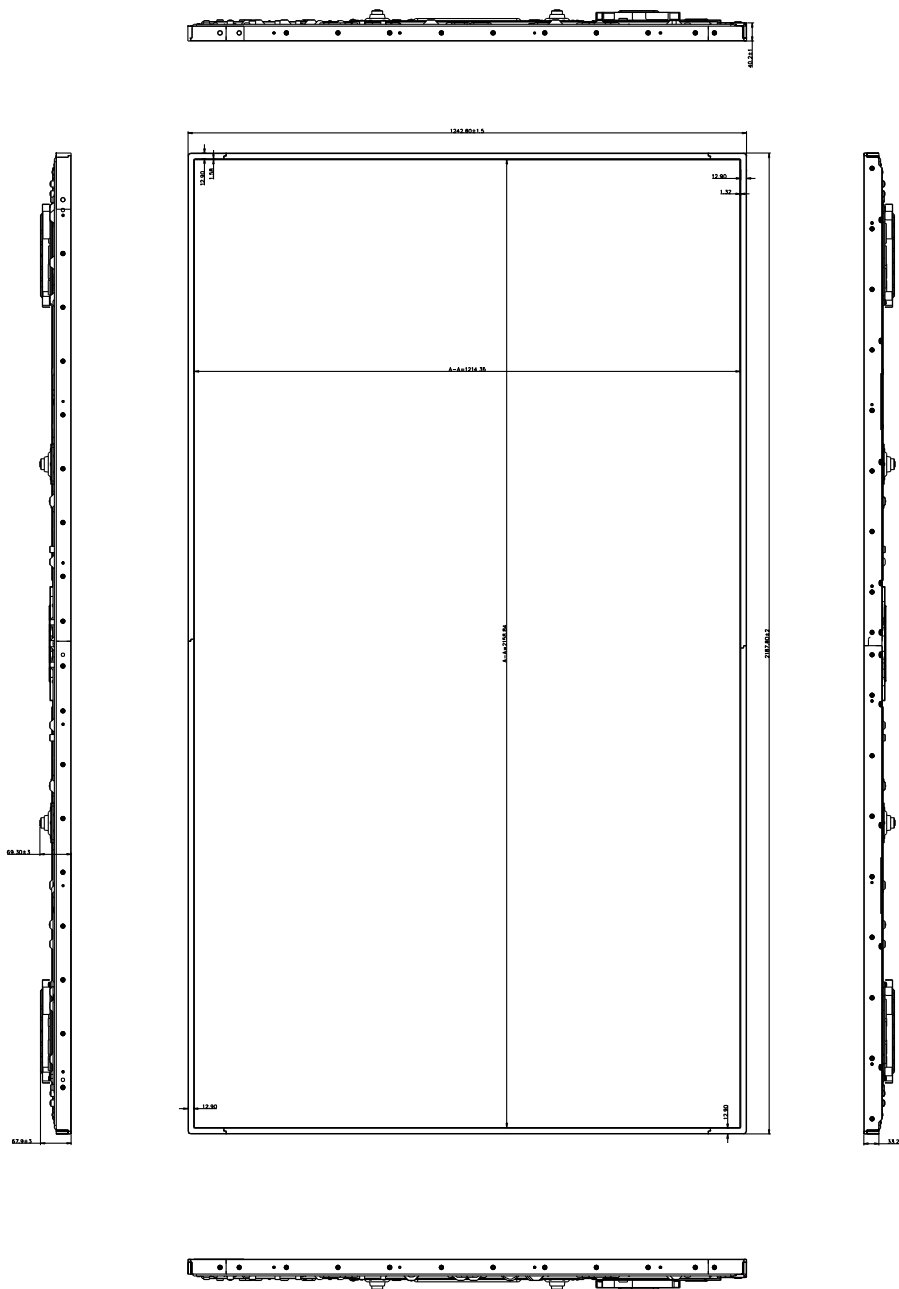

一般公差	A級	B級	C級	D級
0<-0<-10	±0.05	±0.10	±0.20	±0.50
10<-0<-150	±0.10	±0.15	±0.30	±1.00
150<-0<-300	±0.15	±0.2	±0.40	±1.50
300<-0<-600	±0.20	±0.30	±0.60	±2.00
600<-0<-1000	±0.25	±0.40	±0.80	±2.50
1000<-0<-2000	±0.30	±0.50	±1.00	±3.00
角度	±0.5°	±0.8°	±1.0°	±2.0°
圓孔	±0.1	±0.1	±0.3	±0.5

PROPRIETARY NOTE

THIS SPECIFICATION IS THE PROPERTY OF BOE BJ AND SHALL NOT BE REPRODUCED OR COPIED WITHOUT THE WRITTEN PERMISSION OF BOE BJ AND MUST BE RETURNED TO BOE BJ UPON ITS REQUEST



SPEC. NUMBER
S8-64-8A-247

PRODUCT GROUP
DID

REV.
P2

ISSUE DATE
2020.06.10

PAGE
35 OF 35

Figure 5. TFT-LCD Module Outline Dimensions (Back view)

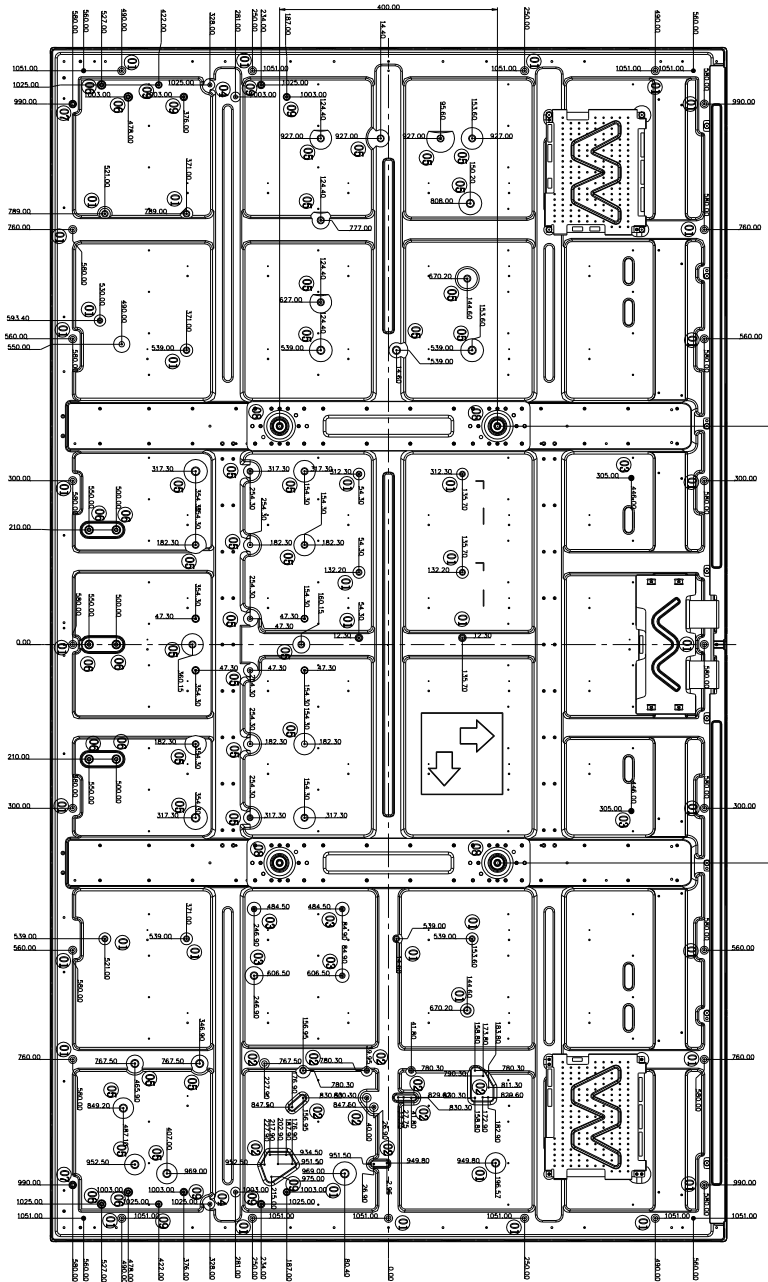

NOTE:
1.USER MOUNTING TORQUE
SPEC:

ITEM	TAP	Max Depth (mm)	Torque (Kgf-cm)
①	M3	6.00	Max 5.00
②	M3	8.00	Max 5.00
③	M3	10.00	Max 5.00
④	M3	12.00	Max 5.00
⑤	M3	14.00	Max 5.00
⑥	M6	12.00	Max 12.00
⑦	M7	12.00	Max 12.00
⑧	M8	12.00	Max 20.00
⑨	M4	12.00	Max 10.00