

SPECIFICATION FOR APPROVAL

() Preliminary Specification

(●) Final Specification

Title	32.0" WUXGA TFT LCD
-------	---------------------

BUYER	General
MODEL	

SUPPLIER	LG Display Co., Ltd.
*MODEL	LD320DPY
SUFFIX	SKA1

APPROVED BY	SIGNATURE DATE
/	_____
/	_____
/	_____

Please return 1 copy for your confirmation with your signature and comments.

APPROVED BY	SIGNATURE DATE
Sungjun Lee/ Team Leader	_____
REVIEWED BY	
Dongsan Kim/ Project Leader	_____
PREPARED BY	
Youngjoo Hong / Engineer	_____

**TV Product Development Dept.
LG Display Co., Ltd.**

Product Specification

CONTENTS

Number	ITEM	Page
	COVER	0
	CONTENTS	1
	RECORD OF REVISIONS	2
1	GENERAL DESCRIPTION	3
2	ABSOLUTE MAXIMUM RATINGS	4
3	ELECTRICAL SPECIFICATIONS	5
3-1	ELECTRICAL CHARACTERISTICS	5
3-2	INTERFACE CONNECTIONS	6
3-3	SIGNAL TIMING SPECIFICATIONS	7
3-4	LVDS SIGNAL SPECIFICATIONS	9
3-5	INTRA INTERFACE SIGNAL SPECIFICATION	12
3-6	COLOR DATA REFERENCE	13
3-7	POWER SEQUENCE	14
4	OPTICAL SPECIFICATIONS	15
5	MECHANICAL CHARACTERISTICS	18
6	MECHANICAL DIMENSION	19
6-1	BOARD ASSEMBLY DIMENSION	19
6-2	CONTROL BOARD ASSEMBLY DIMMENSION	20
7	RELIABILITY	21
8	INTERNATIONAL STANDARDS	22
8-1	SAFETY	22
8-2	ENVIRONMENT	22
9	PACKING	23
9-1	PACKING FORM	23
10	PRECAUTIONS	24
10-1	HANDLING PRECAUTIONS	24
10-2	OPERATING PRECAUTIONS	24
10-3	PROTECTION FILM	25
10-4	STORAGE PRECAUTIONS	25
10-5	PACKING PRECAUTIONS	25

Product Specification

RECORD OF REVISIONS

Revision No.	Revision Date	Page	Description
0.1	Apr. 30, 2016	-	Preliminary Specification(First Draft)
0.2	May. 11, 2016	6	Update MODULE CONNECTOR(CN1) PIN CONFIGURATION
		19	Update Control Board Assembly Dimension
		Appendix-I	Update Pallet Ass'y & Control PCB Packing Ass'y
0.3	Jul. 20. 2016	3, 6	Update MODULE CONNECTOR(CN1) PIN CONFIGURATION
1.0	Aug.09.2016	3	Weight, Surface Treatment (Top) Update
		5	ELECTRICAL CHARACTERISTICS Update
		12	3-5-1. EPI Signal Specification Measure point Update
		15,16	OPTICAL CHARACTERISTICS Update
		18	MECHANICAL CHARACTERISTICS Update
		28	APPENDIX- II-1 Control PCB Label Update
		33	APPENDIX- V-1 Update
1.1	Aug.31.2016	15	OPTICAL CHARACTERISTICS Update
1.2	Sep.06.2016	15,16	OPTICAL CHARACTERISTICS Update

Product Specification

1. General Description

The LD320DPY is a Color Active Matrix Liquid Crystal Display with an integral the Source PCB and Gate implanted on Panel (GIP). The matrix employs a-Si Thin Film Transistor as the active element. It is a transmissive type display operating in the normally black mode. It has a 31.5inch diagonally measured active display area with WUXGA resolution (1080 vertical by 1920 horizontal pixel array). Each pixel is divided into Red, Green, Blue and White sub-pixels or dots which are arranged in vertical stripes. Gray scale or the luminance of the sub-pixel color is determined with a 8-bit gray scale signal for each dot. Therefore, it can present a palette of more than 16.7M(True) colors.

It has been designed to apply the 8-bit 2-port LVDS interface.

It is intended to support LCD TV, PCTV where high brightness, super wide viewing angle, high color gamut, high color depth and fast response time are important.

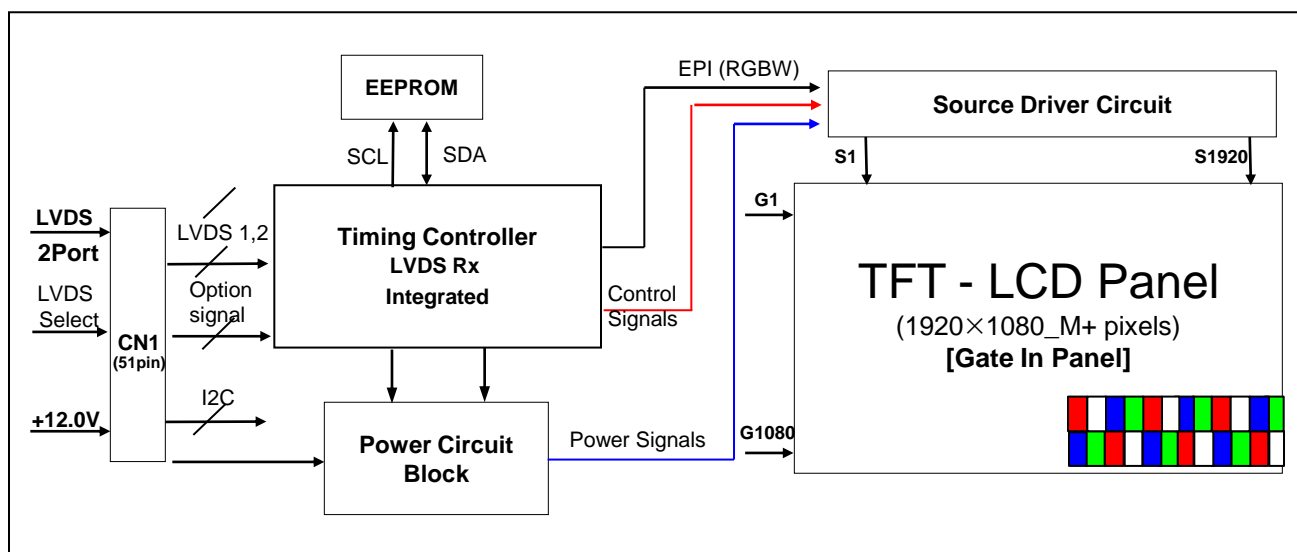

General Features

Active Screen Size	31.55 inches(801.31 mm) diagonal
Outline Dimension	714.0(H) × 411.0(V) X 1.4(D) [mm]
Pixel Pitch	0.36375 [mm] × 0.36375 [mm]
Pixel Format	1920 horiz. by 1080 vert. Pixels, RGBW stripe arrangement
Color Depth	8bit, 16.7 Million colors
Drive IC Data Interface	Source D-IC : 8-bit EPI, gamma reference voltage, and control signals Gate D-IC : Gate In Panel
Viewing Angle (CR>10)	Viewing angle free (R/L 178 (Min.), U/D 178 (Min.))
Weight	0.88Kg (Typ.)
Display Mode	Transmissive mode, Normally black
Surface Treatment (Top)	Hard coating(2H), Anti-reflection treatment of the front polarizer (Reflectance < 2%)

Product Specification

2. Absolute Maximum Ratings

The following items are maximum values which, if exceeded, may cause faulty operation or permanent damage to the LCD module.

Table 1. ABSOLUTE MAXIMUM RATINGS

Parameter		Symbol	Value		Unit	Note
			Min	Max		
Power Input Voltage	LCD Circuit	V _{LCD}	-0.3	+14.0	V _{DC}	1
T-Con Option Selection Voltage		V _{LOGIC}	-0.3	+4.0	V _{DC}	
Operating Temperature		T _{OP}	0	+50	°C	2,3
Storage Temperature(without packing)		T _{ST}	-20	+60	°C	
Panel Front Temperature		T _{SUR}	-	+68	°C	4
Operating Ambient Humidity		H _{OP}	10	90	%RH	2,3
Storage Humidity		H _{ST}	5	90	%RH	

Note1. Ambient temperature condition ($T_a = 25 \pm 2 \text{ }^\circ\text{C}$)

2. Temperature and relative humidity range are shown in the figure below.

Wet bulb temperature should be Max 39°C, and no condensation of water.

3. Gravity mura can be guaranteed below 40°C condition.

4. The maximum operating temperatures is based on the test condition that the surface temperature of display area is less than or equal to 68°C with LCD module alone in a temperature controlled chamber. Thermal management should be considered in final product design to prevent the surface temperature of display area from being over 68°C. The range of operating temperature may be degraded in case of improper thermal management in final product design.

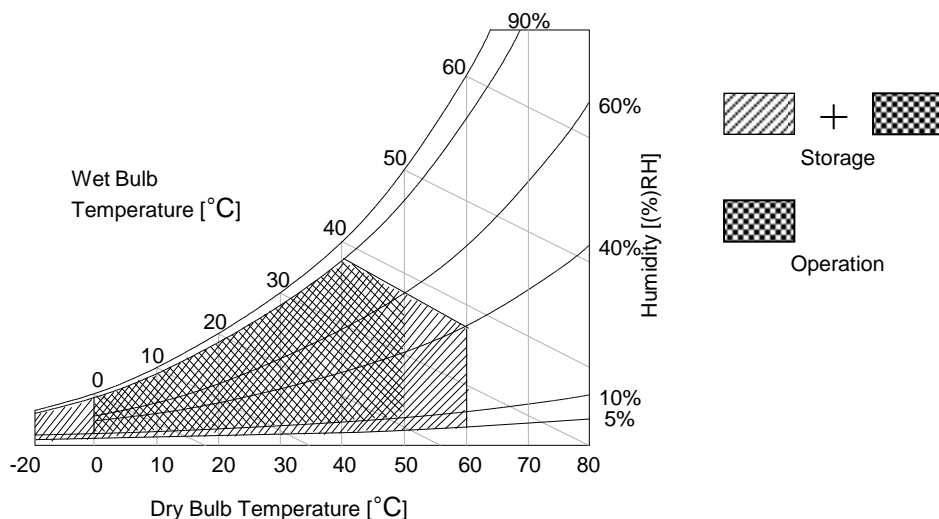

Product Specification

3. Electrical Specifications

3-1. Electrical Characteristics

Table 2. ELECTRICAL CHARACTERISTICS

Parameter		Symbol	Value			Unit	Note
			Min	Typ	Max		
Circuit :							
Power Input Voltage		V _{LCD}	10.8	12.0	14.0	VDC	5
Power Input Current		I _{LCD}	-	467	607	mA	1
			-	639	831	mA	2
T-CON Option Selection Voltage	Input High Voltage	V _{IH}	2.7	-	3.6	VDC	
	Input Low Voltage	V _{IL}	0	-	0.7	VDC	
Power Consumption		P _{LCD}	-	5.6	7.3	Watt	1
Rush current		I _{RUSH}	-	-	5.0	A	3

- Note 1. The specified current and power consumption are under the $V_{LCD}=12.0V$, $T_a=25 \pm 2^\circ C$, $f_v=60Hz$ condition, and mosaic pattern(8 x 6) is displayed and f_v is the frame frequency.
2. The current is specified at the maximum current pattern.
3. The duration of rush current is about 2ms and rising time of power input is 0.5ms (min.).
4. Ripple voltage level is recommended under $\pm 5\%$ of typical voltage
5. Maximum of Power Input Voltage is included with ripple.

White : 255 Gray
Black : 0 Gray

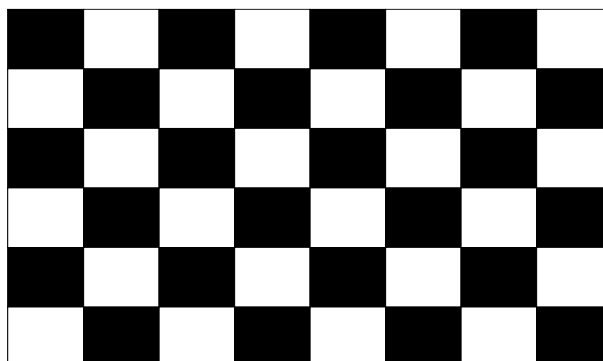

Mosaic Pattern(8 x 6)

Product Specification

3-2. Interface Connections

This LCD module employs two kinds of interface connection, 51-pin connector is used for the module electronics.

3-2-1. LCD Module

- LCD Connector(CN1): FI-RXE51S-HF (manufactured by JAE) or compatible

Table 3. MODULE CONNECTOR(CN1) PIN CONFIGURATION

No	Symbol	Description	No	Symbol	Description
1	NC(Reverse)	No Connection or Ground	27	NC	No Connection (8bit only)
2	NC	No Connection	28	R2AN	SECOND LVDS Receiver Signal (A-)
3	NC	No Connection	29	R2AP	SECOND LVDS Receiver Signal (A+)
4	NC	No Connection	30	R2BN	SECOND LVDS Receiver Signal (B-)
5	NC	No Connection	31	R2BP	SECOND LVDS Receiver Signal (B+)
6	NC	No Connection	32	R2CN	SECOND LVDS Receiver Signal (C-)
7	LVDS Select	'H' =JEIDA , 'L' or Open = VESA	33	R2CP	SECOND LVDS Receiver Signal (C+)
8	NC	No Connection	34	GND	Ground
9	NC	No Connection	35	R2CLKN	SECOND LVDS Receiver Clock Signal(-)
10	NC	No Connection	36	R2CLKP	SECOND LVDS Receiver Clock Signal(+)
11	GND	Ground	37	GND	Ground
12	R1AN	FIRST LVDS Receiver Signal (A-)	38	R2DN	SECOND LVDS Receiver Signal (D-)
13	R1AP	FIRST LVDS Receiver Signal (A+)	39	R2DP	SECOND LVDS Receiver Signal (D+)
14	R1BN	FIRST LVDS Receiver Signal (B-)	40	NC	No Connection
15	R1BP	FIRST LVDS Receiver Signal (B+)	41	NC	No Connection
16	R1CN	FIRST LVDS Receiver Signal (C-)	42	GND	Ground
17	R1CP	FIRST LVDS Receiver Signal (C+)	43	GND	Ground
18	GND	Ground	44	AGP or NSB	'H' or Open= AGP, 'L'= NSB(No signal Black)
19	R1CLKN	FIRST LVDS Receiver Clock Signal(-)	45	GND	Ground
20	R1CLKP	FIRST LVDS Receiver Clock Signal(+)	46	GND	Ground
21	GND	Ground	47	NC	No connection
22	R1DN	FIRST LVDS Receiver Signal (D-)	48	VLCD	Power Supply +12.0V
23	R1DP	FIRST LVDS Receiver Signal (D+)	49	VLCD	Power Supply +12.0V
24	NC	No Connection	50	VLCD	Power Supply +12.0V
25	NC	No Connection	51	VLCD	Power Supply +12.0V
26	GND	Ground	-	-	-

- Note
1. All GND(ground) pins should be connected together to the LCD module's metal frame.
 2. All VLCD (power input) pins should be connected together.
 3. All Input levels of LVDS signals are based on the **EIA 644** Standard.
 4. #1~#6 & #8~#10 NC (No Connection): These pins are used only for LGD (Do not connect)
 5. Specific pin No. **#44** is used for "No signal detection" of system signal interface.
It should be GND for NSB(No Signal Black) during the system interface signal is not.
If this pin is "H", LCD Module displays AGP(Auto Generation Pattern).

Product Specification

3-3. Signal Timing Specifications

Table 4 shows the signal timing required at the input of the LVDS transmitter. All of the interface signal timings should be satisfied with the following specification for normal operation.

Table 4. TIMING TABLE for NTSC & PAL (DE Only Mode)

ITEM		Symbol	Min	Typ	Max	Unit	notes
Horizontal	Display Period	t _{HV}	960	960	960	tCLK	1920 / 2
	Blank	t _{HB}	100	140	240	tCLK	1
	Total	t _{HP}	1060	1100	1200	tCLK	
Vertical	Display Period	t _{VV}	1080	1080	1080	Lines	
	Blank	t _{VB}	20	45	300	Lines	1
	Total	t _{VP}	1100	1125	1380	Lines	

ITEM		Symbol	Min	Typ	Max	Unit	notes
Frequency	DCLK	f _{CLK}	60.00	74.25	78.00	MHz	
	Horizontal	f _H	57.3	67.5	70	KHz	2
	Vertical	f _V	47	60	63	Hz	2

notes: 1. The input of HSYNC & VSYNC signal does not have an effect on normal operation (DE Only Mode).
If you use spread spectrum of EMI, add some additional clock to minimum value for clock margin.

2. The performance of the electro-optical characteristics may be influenced by variance of the vertical refresh rate and the horizontal frequency

3. Spread Spectrum Rate (SSR) for 50KHz ~ 100kHz Modulation Frequency(FMOD) is calculated by $(7 - 0.06 \cdot F_{mod})$, where Modulation Frequency (FMOD) unit is KHz.
LVDS Receiver Spread spectrum Clock is defined as below figure

※ Timing should be set based on clock frequency.

Product Specification

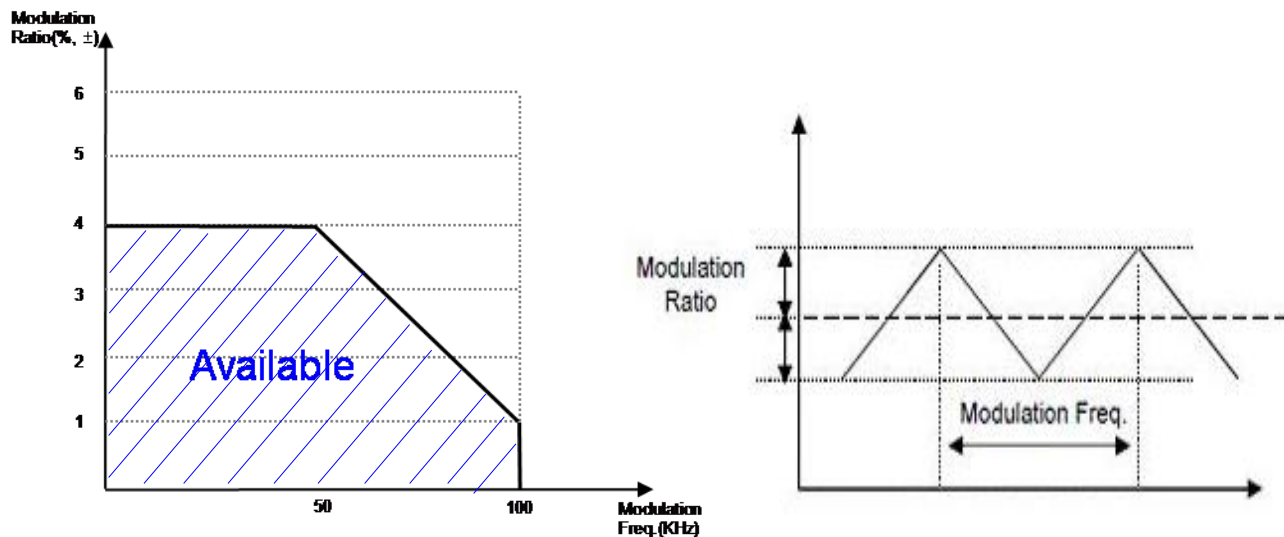

※ Please pay attention to the followings when you set Spread Spectrum Rate(SSR) and Modulation Frequency(FMOD)

1. Please set proper Spread Spectrum Rate(SSR) and Modulation Frequency (FMOD) of TV system LVDS output.
2. Please check FOS after you set Spread Spectrum Rate(SSR) and Modulation Frequency(FMOD) to avoid abnormal display. Especially, harmonic noise can appear when you use Spread Spectrum under FMOD 30 KHz.

3-4. LVDS Signal Specification

3-4-1. LVDS Input Signal Timing Diagram

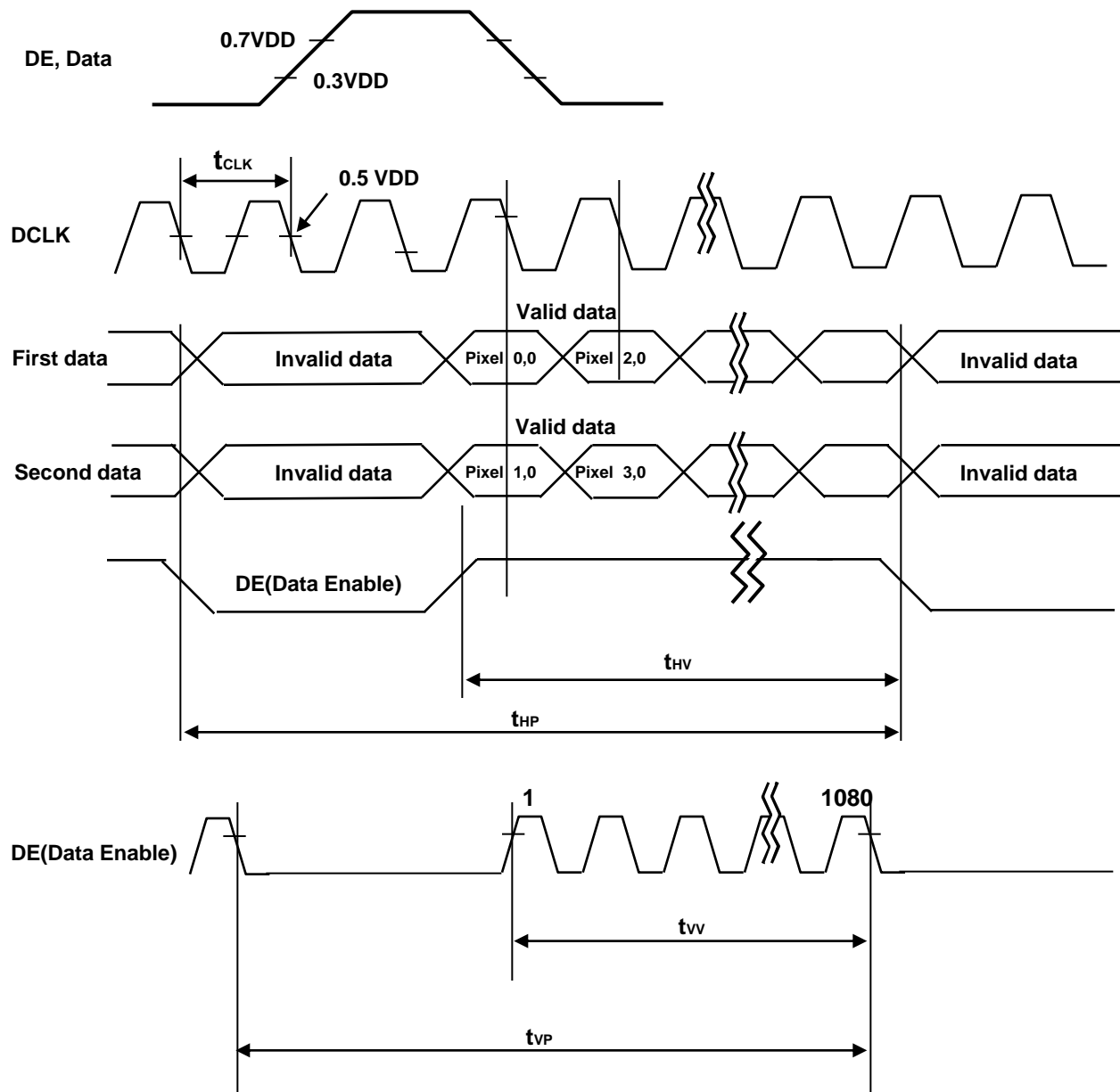

Product Specification

3-4-2. LVDS Input Signal Characteristics

1) DC Specification

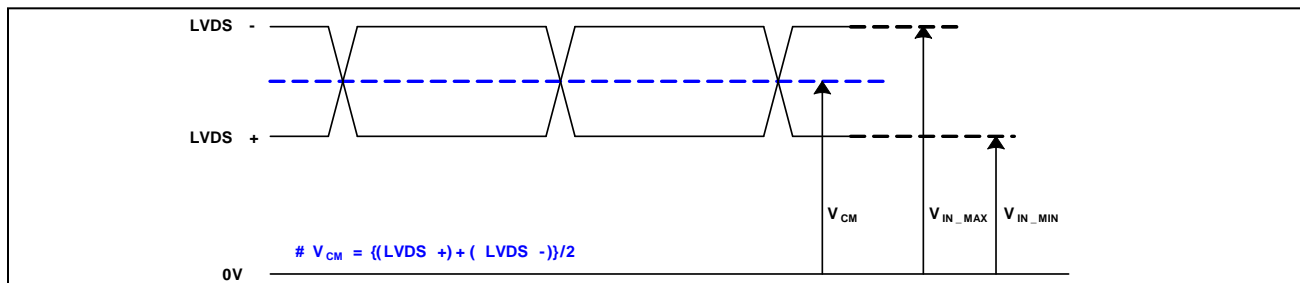

Description	Symbol	Min	Max	Unit	notes
LVDS Common mode Voltage	V_{CM}	1.0	1.5	V	-
LVDS Input Voltage Range	V_{IN}	0.7	1.8	V	-
Change in common mode Voltage	ΔV_{CM}	-	250	mV	-

2) AC Specification

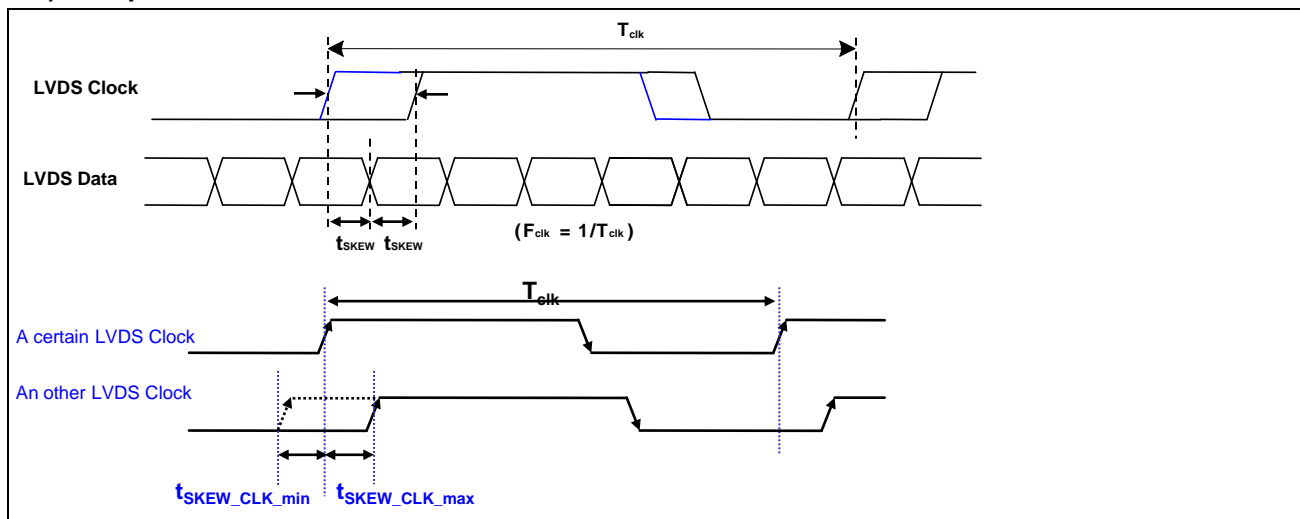

Description	Symbol	Min	Max	Unit	notes
LVDS Differential Voltage	V_{TH}	100	600	mV	Tested with Differential Probe 2
	V_{TL}	-600	-100	mV	
LVDS Clock to Data Skew	t_{SKEW}	-	$ (0.2 * T_{clk})/7 $	ps	-
Effective time of LVDS	t_{eff}	$ \pm 360 $	-	ps	-
LVDS Clock to Clock Skew (Each other)	t_{SKEW_CLK}	-	$ 1/7 * T_{clk} $	ps	-

notes 1. All Input levels of LVDS signals are based on the EIA 644 Standard.

2. LVDS Differential Voltage is defined within t_{eff}

Product Specification

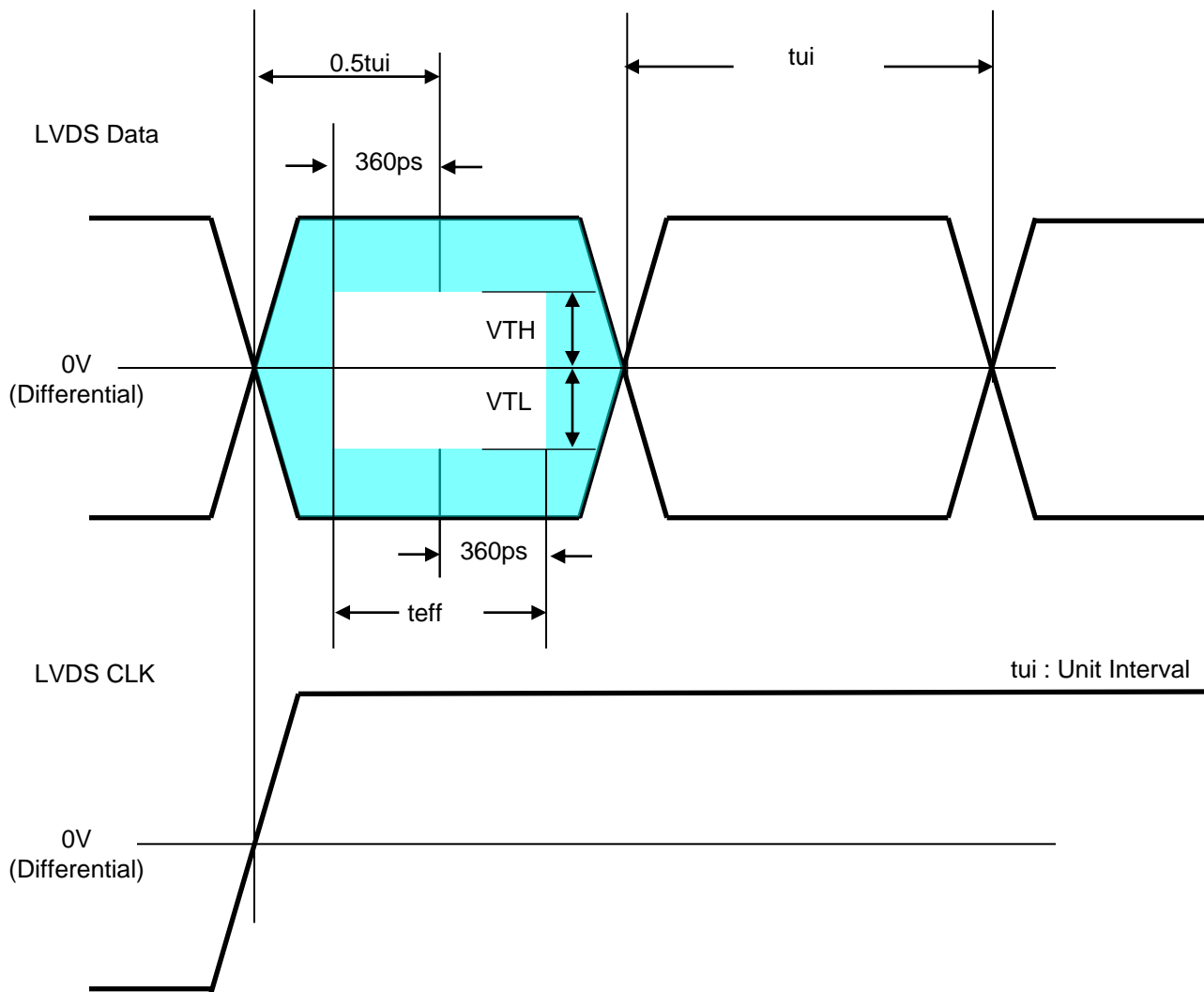

* This accumulated waveform is tested with differential probe

3-5. Intra interface Signal Specification

3-5-1. EPI Signal Specification

Table 5. ELECTRICAL CHARACTERISTICS

Parameter	Symbol	Condition	MIN	TYP	MAX	Unit	notes
Logic & EPI Power Voltage	VCC	-	1.62	1.8	1.98	V _{DC}	
EPI input common voltage	VCM	LVDS Type	0.8	VCC/2	1.3	V	
EPI input differential voltage	V _{diff}	-	150	-	500	mV	
EPI Input eye diagram	V _{eye}	-	90	-	-	mV	
Effective Veye width time	B1&B2		0.25	-	-	UI	

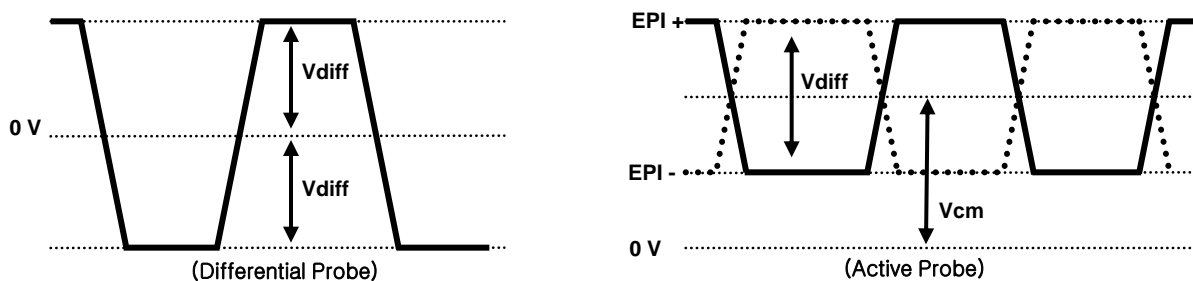

EPI Differential signal characteristics

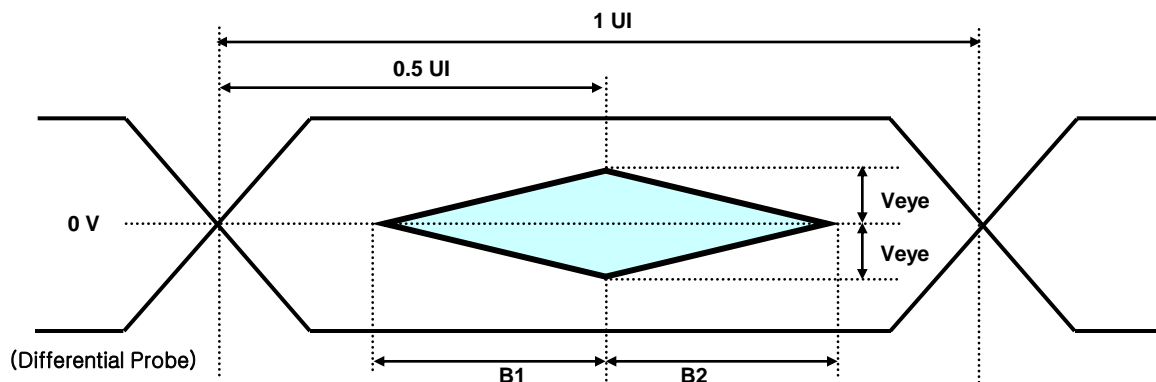

Eye Pattern of EPI Input

*Source PCB



FIG. 3 Measure point

Product Specification

3-6. Color Data Reference

The brightness of each primary color(red,green,blue) is based on the 10bit gray scale data input for the color. The higher binary input, the brighter the color. Table 6 provides a reference for color versus data input.

Table 6. COLOR DATA REFERENCE

[8bit input]

Color		Input Color Data																							
		RED								GREEN								BLUE							
		MSB							LSB	MSB							LSB	MSB							LSB
R7	R6	R5	R4	R3	R2	R1	R0	G7	G6	G5	G4	G3	G2	G1	G0	B7	B6	B5	B4	B3	B2	B1	B0		
Basic Color	Black	0	0	0	0	0	0	0	0	0	0	0	0	0	0	0	0	0	0	0	0	0	0	0	0
	Red (255)	1	1	1	1	1	1	1	1	0	0	0	0	0	0	0	0	0	0	0	0	0	0	0	0
	Green (255)	0	0	0	0	0	0	0	0	1	1	1	1	1	1	1	1	0	0	0	0	0	0	0	0
	Blue (255)	0	0	0	0	0	0	0	0	0	0	0	0	0	0	0	0	1	1	1	1	1	1	1	1
	Cyan	0	0	0	0	0	0	0	0	1	1	1	1	1	1	1	1	1	1	1	1	1	1	1	1
	Magenta	1	1	1	1	1	1	1	1	0	0	0	0	0	0	0	0	1	1	1	1	1	1	1	1
	Yellow	1	1	1	1	1	1	1	1	1	1	1	1	1	1	1	1	0	0	0	0	0	0	0	0
	White	1	1	1	1	1	1	1	1	1	1	1	1	1	1	1	1	1	1	1	1	1	1	1	1
RED	RED (000)	0	0	0	0	0	0	0	0	0	0	0	0	0	0	0	0	0	0	0	0	0	0	0	0
	RED (001)	0	0	0	0	0	0	0	1	0	0	0	0	0	0	0	0	0	0	0	0	0	0	0	0
	
	RED (254)	1	1	1	1	1	1	1	0	0	0	0	0	0	0	0	0	0	0	0	0	0	0	0	0
	RED (255)	1	1	1	1	1	1	1	1	0	0	0	0	0	0	0	0	0	0	0	0	0	0	0	0
GREEN	GREEN (000)	0	0	0	0	0	0	0	0	0	0	0	0	0	0	0	0	0	0	0	0	0	0	0	0
	GREEN (001)	0	0	0	0	0	0	0	0	0	0	0	0	0	0	0	1	0	0	0	0	0	0	0	0
	
	GREEN (254)	0	0	0	0	0	0	0	0	1	1	1	1	1	1	1	0	0	0	0	0	0	0	0	0
	GREEN (255)	0	0	0	0	0	0	0	0	1	1	1	1	1	1	1	1	0	0	0	0	0	0	0	0
BLUE	BLUE (000)	0	0	0	0	0	0	0	0	0	0	0	0	0	0	0	0	0	0	0	0	0	0	0	0
	BLUE (001)	0	0	0	0	0	0	0	0	0	0	0	0	0	0	0	0	0	0	0	0	0	0	0	1
	
	BLUE (254)	0	0	0	0	0	0	0	0	0	0	0	0	0	0	0	0	1	1	1	1	1	1	1	0
	BLUE (255)	0	0	0	0	0	0	0	0	0	0	0	0	0	0	0	0	1	1	1	1	1	1	1	1

Product Specification

3-7. Power Sequence

3-7-1. LCD Driving circuit

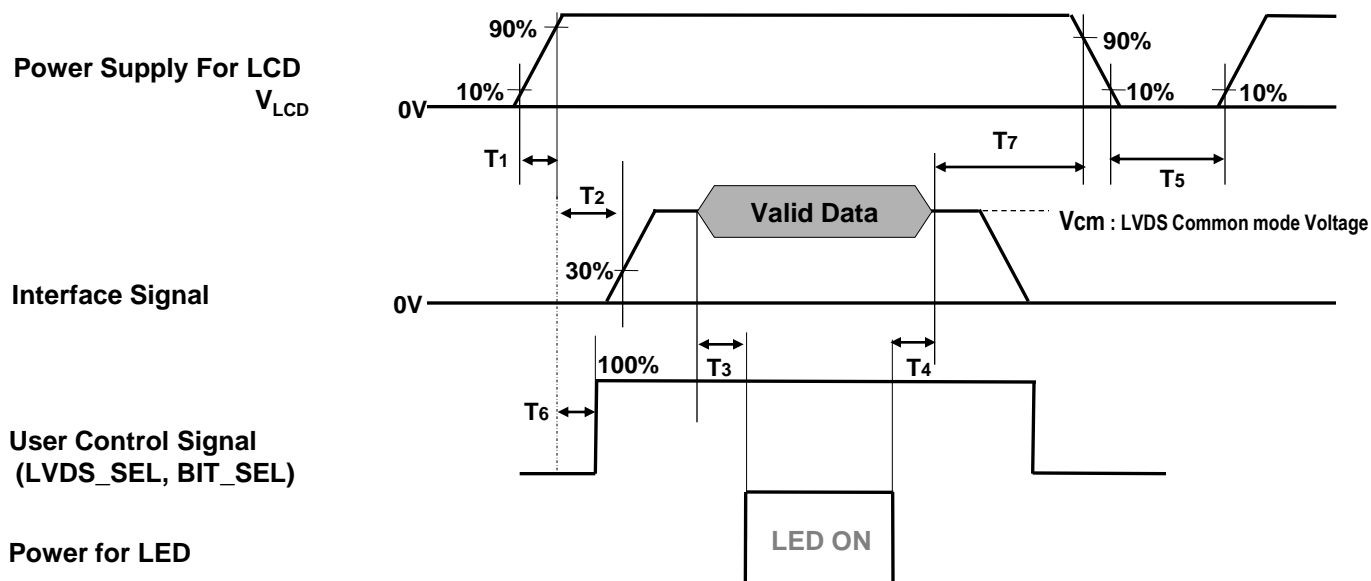

Table 8. POWER SEQUENCE

Parameter	Value			Unit	Note
	Min	Typ	Max		
T1	0.5	-	20	ms	1
T2	0	-	-	ms	2
T3	400	-	-	ms	3
T4	100	-	-	ms	3
T5	1.0	-	-	s	4
T6	0	-	T2	ms	5
T7	0	-	-	ms	6

- Note :**
1. Even though T1 is over the specified value, there is no problem if I2T spec of fuse is satisfied.
 2. If T2 is satisfied with specification after removing LVDS Cable, there is no problem.
 3. The T3 / T4 is recommended value, the case when failed to meet a minimum specification, abnormal display would be shown. There is no reliability problem.
 4. T5 should be measured after the Module has been fully discharged between power off and on period.
 5. If the on time of signals (Interface signal and user control signals) precedes the on time of Power (V_{LCD}), it will be happened abnormal display. When T6 is NC status, T6 doesn't need to be measured.
 6. It is recommendation specification that T7 has to be 0ms as a minimum value.
 - ※ Please avoid floating state of interface signal at invalid period.
 - ※ When the power supply for LCD (VLCD) is off, be sure to pull down the valid and invalid data to 0V.

Product Specification

4. Optical Specification

Optical characteristics are determined after the unit has been 'ON' and stable in a dark environment at $25\pm 2^{\circ}\text{C}$. The values are specified at 50cm from the LCD surface at a viewing angle of Φ and θ equal to 0° .

FIG. 1 shows additional information concerning the measurement equipment and method.

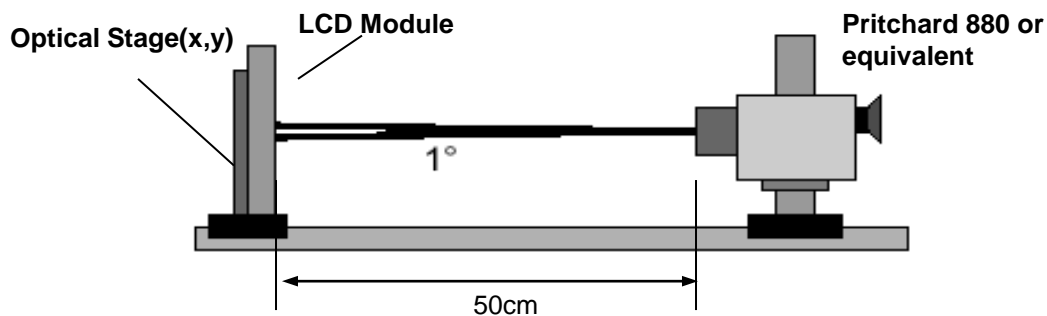

FIG. 1 Optical Characteristic Measurement Equipment and Method

$T_a = 25\pm 2^{\circ}\text{C}$, $V_{\text{LCD}} = 12.0\text{V}$, $f_v = 60\text{Hz}$, $D_{\text{clk}} = 74.25\text{MHz}$,
Light Source : D65 Standard

Table 8. OPTICAL CHARACTERISTICS

Parameter		Symbol	Value			Unit	Note
			Min	Typ	Max		
Contrast Ratio		CR	850	1200	-		1
Response Time	Gray to Gray	G to G _{BW}		9	13	ms	2
Transmittance		T	7.77	8.63		%	3
Color Coordinates [CIE1931]	RED	R _x	Typ -0.03	0.655	Typ +0.03		4
		R _y		0.328			
	GREEN	G _x		0.281			
		G _y		0.581			
	BLUE	B _x		0.134			
		B _y		0.135			
Viewing Angle (CR>10)							
	x axis, right($\phi=0^{\circ}$)	θ_r	89	-	-	degree	5
	x axis, left ($\phi=180^{\circ}$)	θ_l	89	-	-		
	y axis, up ($\phi=90^{\circ}$)	θ_u	89	-	-		
	y axis, down ($\phi=270^{\circ}$)	θ_d	89	-	-		
Gray Scale			-	-	-		6

Product Specification

Note : 1. Contrast Ratio(CR) is defined mathematically as :

$$\text{Contrast Ratio} = \frac{\text{Surface Luminance with all white pixels}}{\text{Surface Luminance with all black pixels}}$$

It is measured at center 1-point.

The contrast ratio is valued with operating condition of LGD's standard BLU

2. Response time is the time required for the display to transit from any gray to white (Rise Time, TrR) and from any gray to black (Decay time, TrD). For additional information see the FIG. 3.

※ G to G Spec stands for average value of all measured points.

Photo Detector : RD-80S / Field : 2 °

The response time is valued with operating condition of LGD's standard BLU

3. The value of transmittance should be extracted using the standard light source of D65
4. The value of color coordinates should be extracted using the standard light source of D65
5. Viewing angle is the angle at which the contrast ratio is greater than 10. The angles are determined for the horizontal or x axis and the vertical or y axis with respect to the z axis which is normal to the LCD module surface. For more information, see the FIG. 4.
6. Gray scale specification
Gamma Value is approximately 2.2. For more information, see the Table 9.

Table 9. GRAY SCALE SPECIFICATION

Gray Level	Luminance [%] (Typ)
L0	0.083
L15	0.27
L31	1.04
L47	2.49
L63	4.68
L79	7.66
L95	11.5
L111	16.1
L127	21.6
L143	28.1
L159	35.4
L175	43.7
L191	53.0
L207	63.2
L223	74.5
L239	86.7
L255	100

Product Specification

Response time is defined as the following figure and shall be measured by switching the input signal for "Gray(N)" and "Black or White".

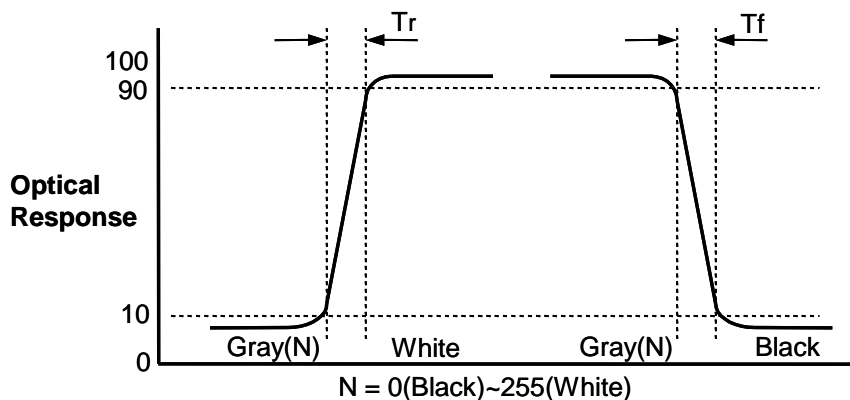

FIG. 3 Response Time

Dimension of viewing angle range

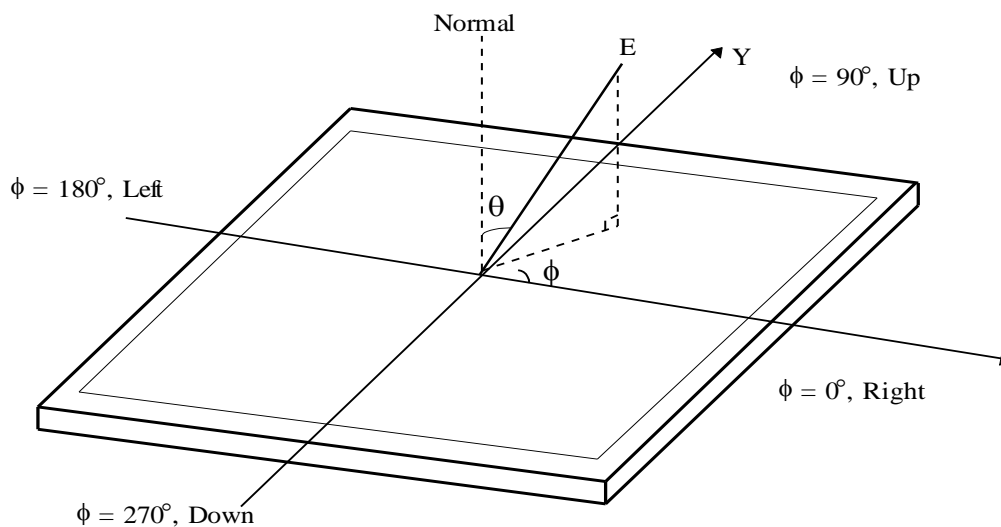

FIG. 4 Viewing Angle

Product Specification

5. Mechanical Characteristics

Table 10 provides general mechanical characteristics.

Table 10. MECHANICAL CHARACTERISTICS

Item	Value	
Outline Dimension (Only Glass)	Horizontal	714.0mm
	Vertical	411.0mm
	Thickness	1.4mm
Active Display Area	Horizontal	698.4mm
	Vertical	392.9mm
Weight	0.88kg (Typ.)	
Surface Treatment	Hard coating(2H), Anti-glare low reflection treatment of the front polarizer (Haze 3%(Typ))	

Note : Please refer to a mechanical drawing in terms of tolerance at the next page.

Product Specification

6. Mechanical Dimension

6-1. Board Assembly Dimension

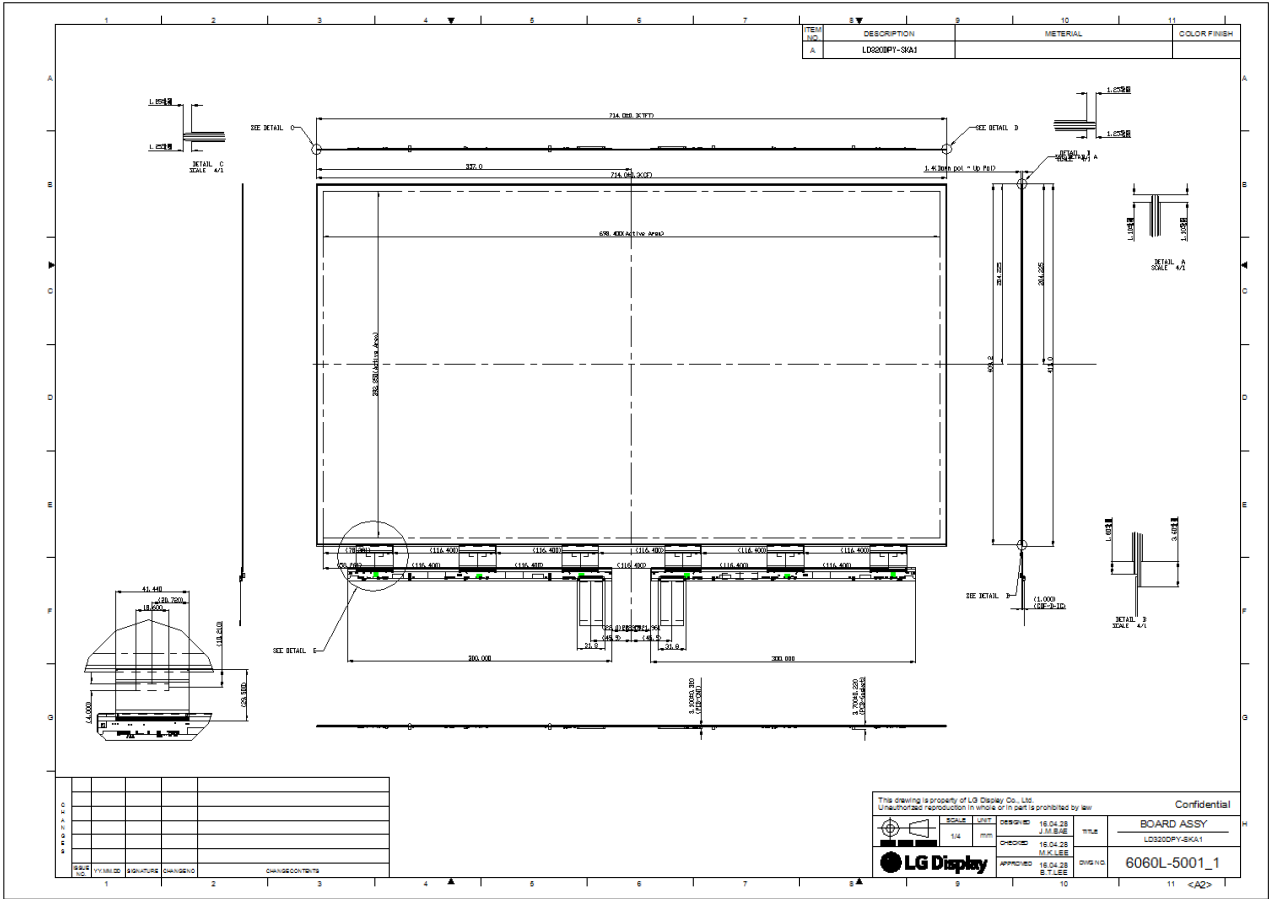



Date	Version
16.04.28	1.0

Product Specification

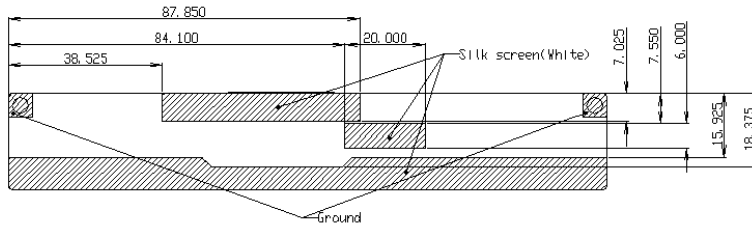
6-2. Control Board Assembly Dimension

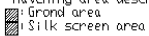

NOTE

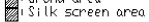
1. This drawing describes the necessary dimension in Control board to assembly with customer's backlight system.
2. The specified dimension, non-specified dimension and its tolerances can be changeable, and hence values are used for reference only.
3. Hatching area describes as below:

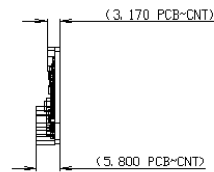
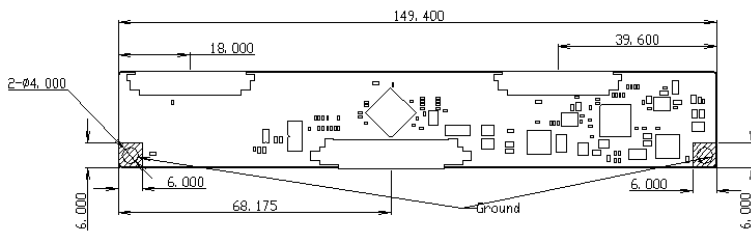
 -  Ground area
 -  Silk screen area



Date	Version
16.05.11	1.0

Product Specification

7. Reliability**Table 11. ENVIRONMENT TEST CONDITION**

No.	Test Item	Condition
1	High temperature storage test	Ta= 60°C 90% 240h
2	Low temperature storage test	Ta= -20°C 240h
3	High temperature operation test	Ta= 50°C 50%RH 500h
4	Low temperature operation test	Ta= 0°C 500h
5	Humidity condition Operation	Ta= 40 °C ,90%RH
6	Altitude operating storage / shipment	0 - 16,400 ft 0 - 40,000 ft

Note : Before and after Reliability test, LCM should be operated with normal function.

8. International Standards

8-1. Safety

- a) UL 60065, Underwriters Laboratories Inc.
Audio, Video and Similar Electronic Apparatus - Safety Requirements.
- b) CAN/CSA C22.2 No.60065:03, Canadian Standards Association.
Audio, Video and Similar Electronic Apparatus - Safety Requirements.
- c) IEC 60065, The International Electrotechnical Commission (IEC).
Audio, Video and Similar Electronic Apparatus - Safety Requirements.

8-2. Environment

- a) RoHS, Directive **2011/65/EU** of the European Parliament and of the council of **8 June 2011**

9. Packing

9-1. Packing Form

- a) Package quantity in one Pallet : 306 pcs
- b) Pallet Size : 1140 mm(L) X 990 mm(W) X 1230 mm(H)

Product Specification

10. Precautions

Please pay attention to the followings when you use this TFT LCD module.

10-1. Handling Precautions

- (1) Please attach the surface transparent protective film to the surface in order to protect the polarizer. Transparent protective plate should have sufficient strength in order to resist external force.
- (2) Acetic acid type and chlorine type materials for the cover case are not desirable because the former generates corrosive gas of attacking the polarizer at high temperature and the latter causes circuit break by electro-chemical reaction.
- (3) Do not touch, push or rub the exposed polarizers with glass, tweezers or anything harder than HB pencil lead. And please do not rub with dust clothes with chemical treatment. Do not touch the surface of polarizer for bare hand or greasy cloth. (Some cosmetics are detrimental to the polarizer.)
- (4) After removing the protective film, when the surface becomes dusty, please wipe gently with absorbent cotton or other soft materials like chamois soaked with petroleum benzene. Do not use acetone, toluene and alcohol because they cause chemical damage to the polarizer.
- (5) Wipe off saliva or water drops as soon as possible. Their long time contact with polarizer causes deformations and color fading.
- (6) Since a module is composed of electronic circuits, it is not strong to electrostatic discharge. Make certain that treatment persons are connected to ground through wrist band etc. And don't touch interface pin directly. Panel ground path should be connected to metal ground.
- (7) Please make sure to avoid external forces applied to the Source PCB and D-IC during the process of handling or assembling the TV set. If not, it causes panel damage or malfunction.
- (8) Panel and BLU should be protected from the static electricity. If not, it causes IC damage.
- (9) Do not pull or fold the source D-IC which connect the source PCB and the panel.
- (10) Panel(board ass'y) should be put on the BLU structure precisely to avoid mechanical impact.
- (11) FFC Cable should be connected between System board and Source PCB correctly.
- (12) Mechanical structure for backlight system should be designed for sustaining board ass'y safely.
- (13) Surface temperature of the Source D-IC should be controlled under 100°C with TV Set status. If not, problems such as IC damage or decrease of lifetime could occur.

10-2. Operating Precautions

- (1) Response time depends on the temperature. (In lower temperature, it becomes longer.)
- (2) Brightness depends on the temperature. (In lower temperature, it becomes lower.)
And in lower temperature, Stable time (required time that brightness is stable after turned on) becomes longer
- (3) Be careful for condensation at sudden temperature change. Condensation makes damage to polarizer or electrical contacted parts. And after fading condensation, smear or spot will occur.
- (4) When fixed patterns are displayed for a long time, remnant image is likely to occur.
- (5) Module has high frequency circuits. Sufficient suppression to the electromagnetic interference shall be done by system manufacturers. Grounding and shielding methods may be important to minimize the interference.

Product Specification

10-3. Protection Film

- (1) Please keep attaching the protection film before assembly.
- (2) Please peel off the protection film slowly.
- (3) Please peel off the protection film just like shown in the Fig.1
- (4) Ionized air should be blown over during the peeling.
- (5) Source PCB should be connected to the ground when peel off the protection film.
- (6) The protection film should not be contacted to the source D-IC during peeling it off.

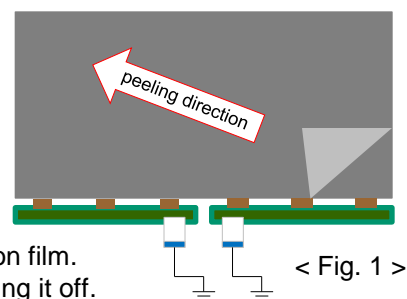

< Fig. 1 >

10-4. Storage Precautions

When storing modules as spares for a long time, the following precautions are necessary.

- (1) Temperature : 5 ~ 40 °C
- (2) Humidity : 35 ~ 75 %RH
- (3) Period : 6 months
- (4) Control of ventilation and temperature is necessary.
- (5) Please make sure to protect the product from strong light exposure, water or moisture. Be careful for condensation.
- (6) Please keep the modules at a circumstance shown below Fig. 2

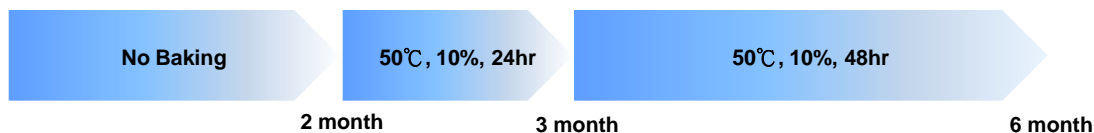

< Fig. 2 >

10-5. Packing Precautions

Product assembled into module should be stored in the Al-bag(cover case).

Product Specification

APPENDIX-I-1

■ Pallet Ass'y

- a) B/Ass'y Qty + PE Sheet / Box : 17pcs + 18pcs
 b) B/Ass'y Qty / Pallet : 306pcs
 c) Box Qty / Pallet : 9Box

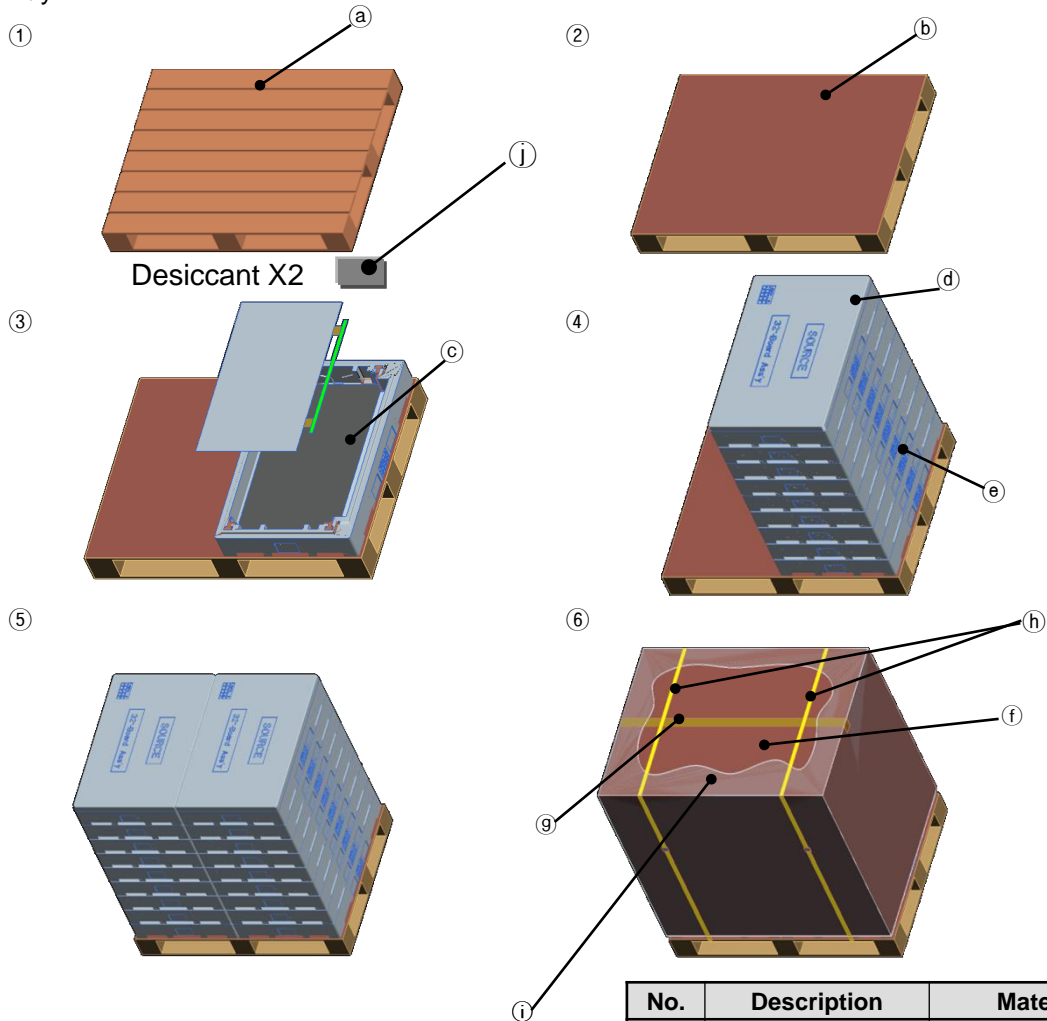

No.	Description	Material
①	Pallet	Plywood
②	Carton Plate	Single Wall
③	PE Sheet	LDPE
④	Top Packing	EPS
⑤	Bottom Packing	EPS
⑥	Angle Packing	Single Wall
⑦	Tape	OPP
⑧	Band	PP
⑨	Wrap	L-LDPE
⑩	Desiccant	Power Dry

Product Specification

APPENDIX-I-2

■ Control PCB Packing Ass'y

- a) Control PCB Qty / Box : 70 pcs
- b) Tray Qty / Box : 8Tray (Upperst Tray Is empty)
- c) Tray Size : 466 X 353 X 16
- d) Box size : 468 X 355 X 98

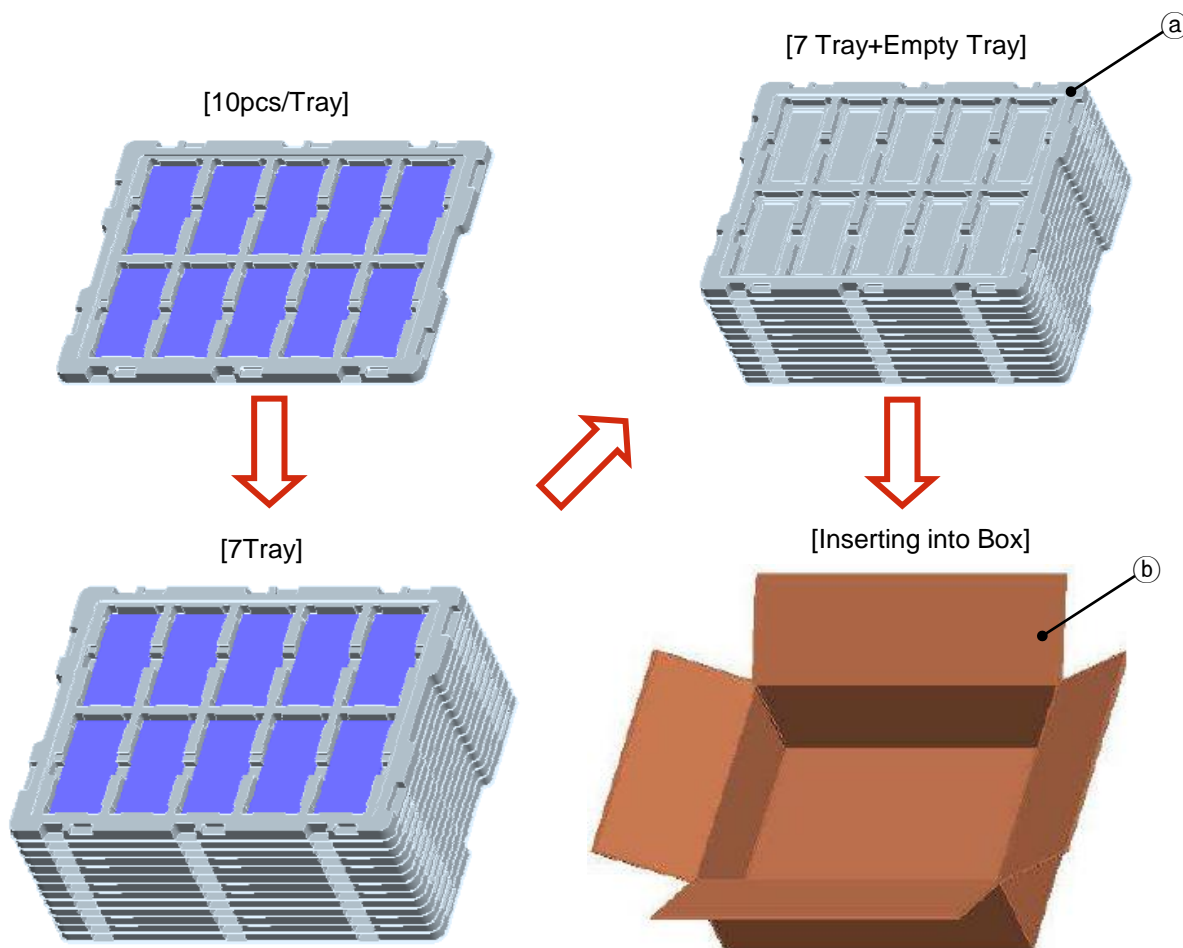

No.	Description	Material
(a)	Tray	PET
(b)	Box	Paper(SW)

Product Specification

APPENDIX- II-1

■ Serial Label

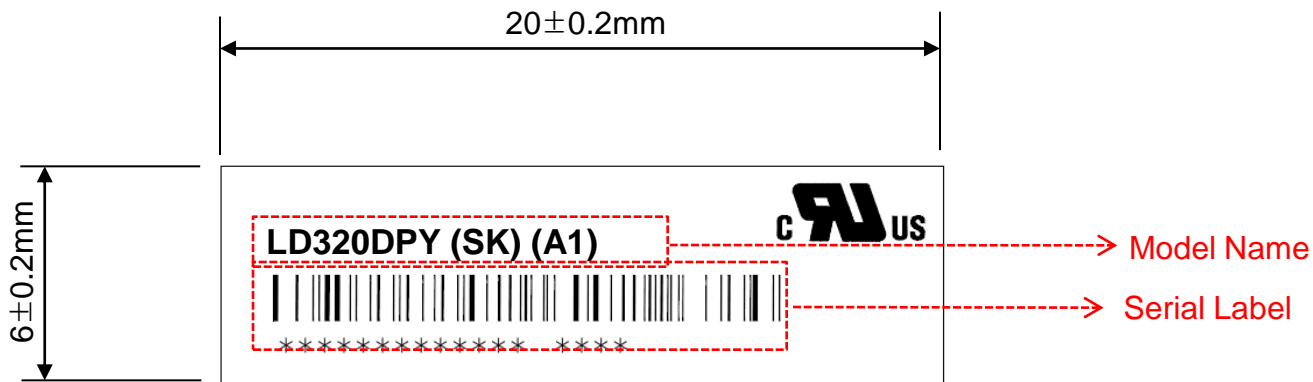

■ Control PCB Label

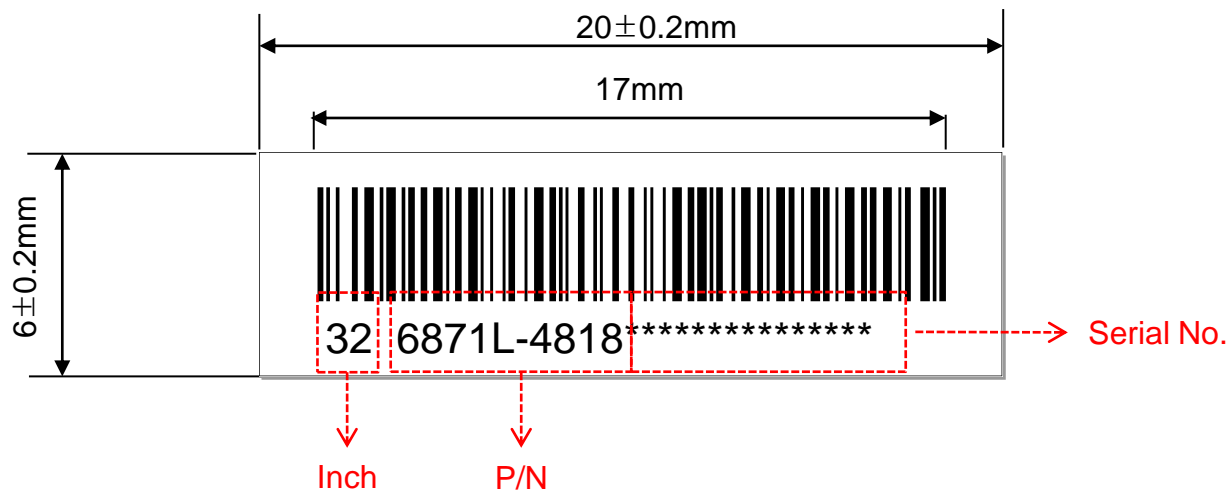

Product Specification

APPENDIX- II-2

■ BOX Label

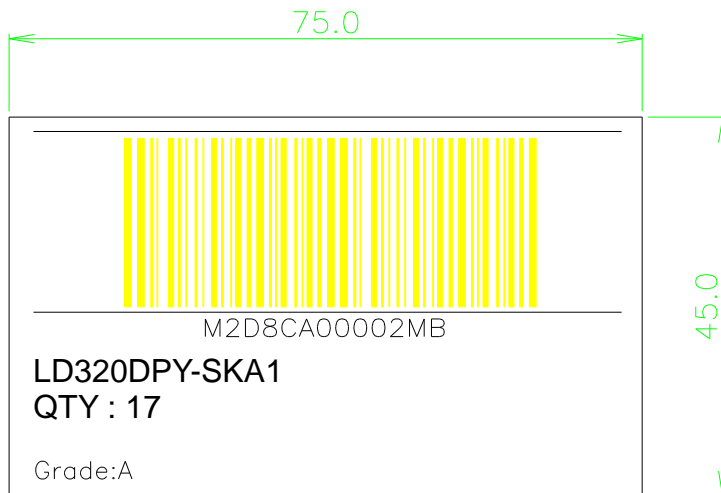

■ Pallet Label



Product Specification

APPENDIX- III-1

■ Required signal assignment for Flat Link (Thine : THC63LVD103) Transmitter(Pin7= "L" or "NC")

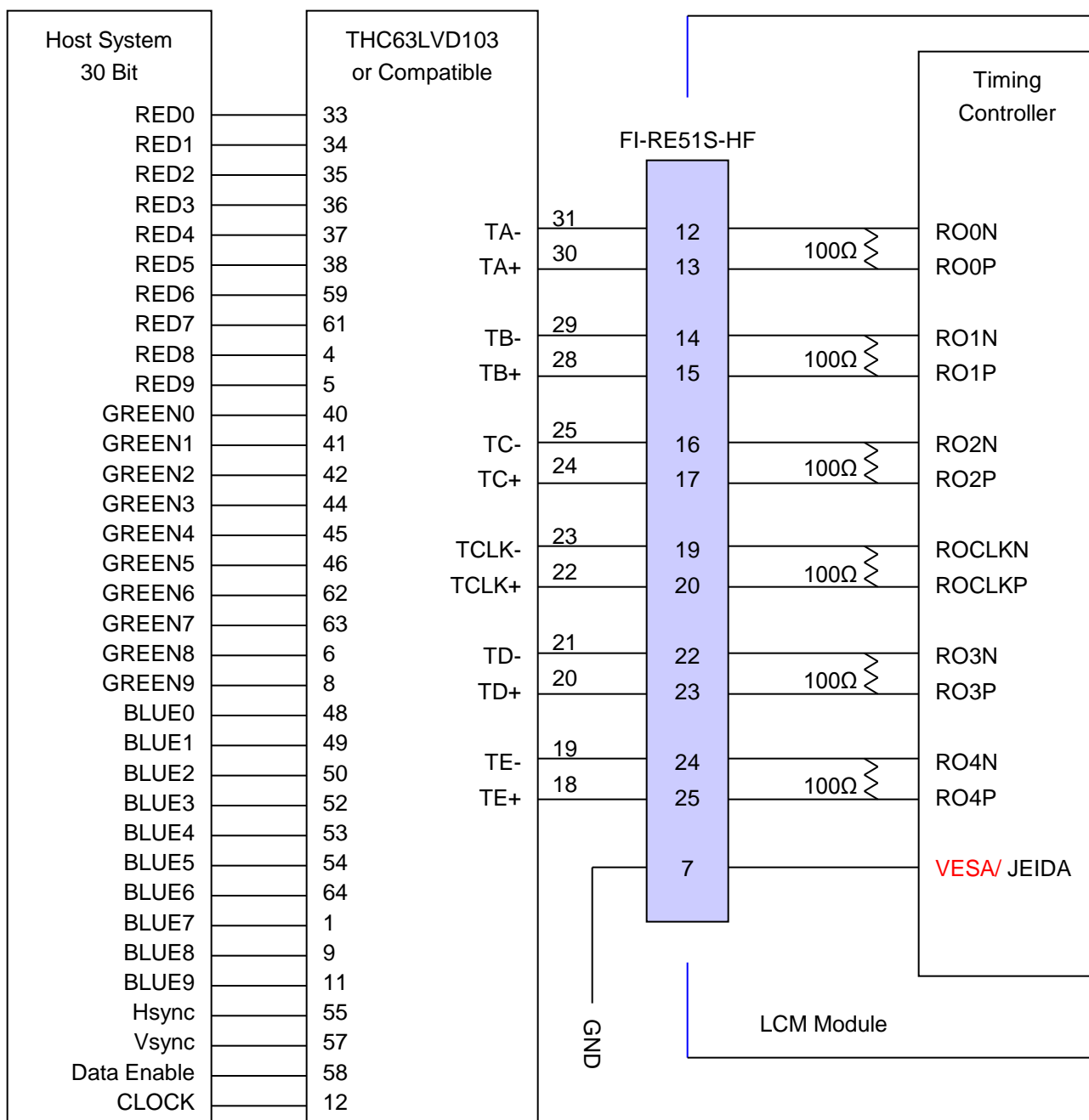

Note: 1. The LCD module uses a 100 Ohm[Ω] resistor between positive and negative lines of each receiver input.

2. Refer to LVDS Transmitter Data Sheet for detail descriptions. (THC63LVD103 or Compatible)

3. '9' means MSB and '0' means LSB at R,G,B pixel data.

Product Specification

APPENDIX- III-2

■ Required signal assignment for Flat Link (Thine : THC63LVD103) Transmitter(Pin7= "H")

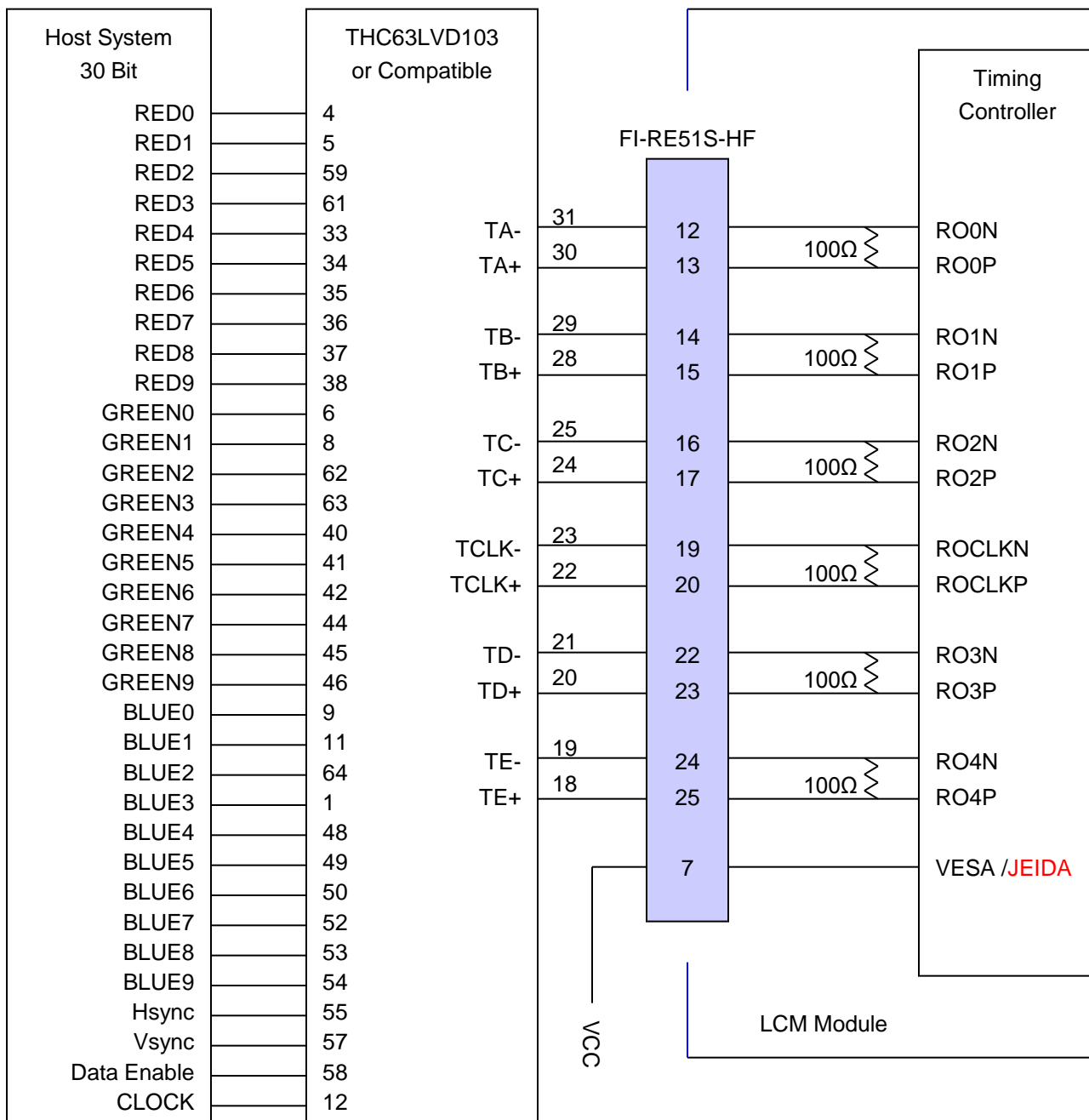

Note :1. The LCD module uses a 100 Ohm[Ω] resistor between positive and negative lines of each receiver input.

2. Refer to LVDS Transmitter Data Sheet for detail descriptions. (THC63LVD103 or Compatible)

3. '9' means MSB and '0' means LSB at R,G,B pixel data.

Product Specification

APPENDIX- IV-2

■ LVDS Data-Mapping Information (8 Bit)

1) LVDS Select : "H" Data-Mapping (JEIDA format)

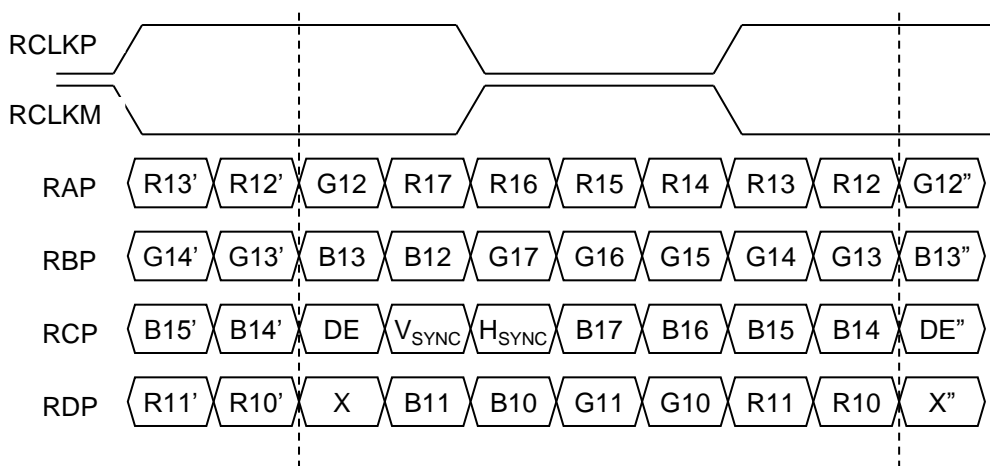

2) LVDS Select : "L" Data-Mapping (VESA format)

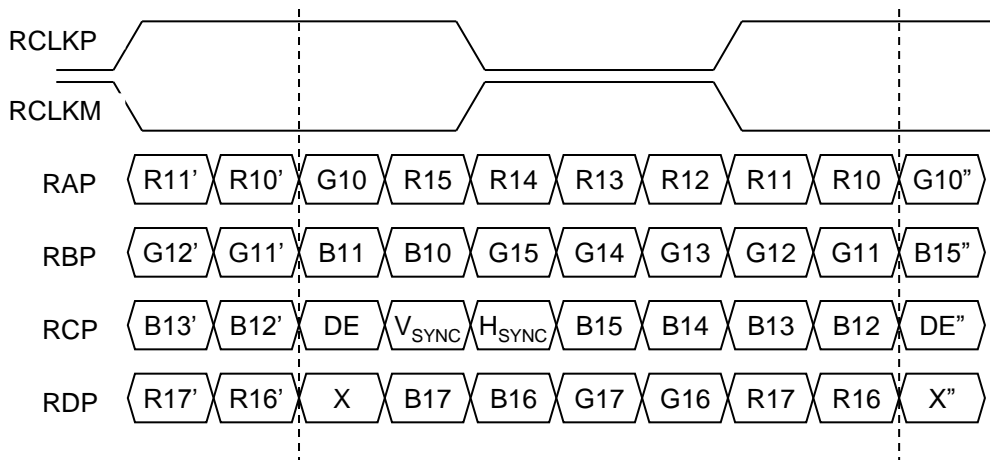

APPENDIX- V-1

■ Option Pin Circuit Block Diagram

1) Circuit Block Diagram of LVDS Format Selection pin

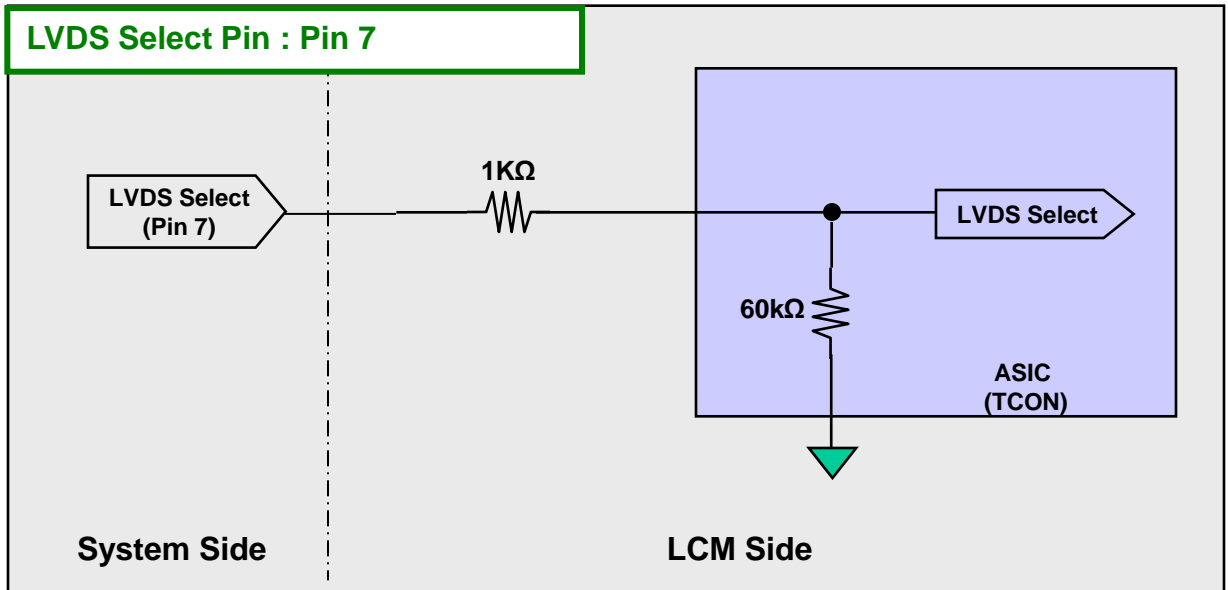

APPENDIX-VIII

■ The reference method of BL dimming

It is recommended to use synchronous V-sync frequency to prevent waterfall
(Vsync * 2 =P-Dim Frequency)