

### Feature

1. Operating Temperature Range: -40°C - +85°C
2. Isolation Voltage: 1500VDC
3. 4:1 Wide Input Voltage Range
4. High efficiency up to 88%
5. With the input undervoltage protection,output short circuit protection and output overcurrent protection mechanism
6. Fields of application: industry, industrial control, instrumentation, communication, rail transit, etc

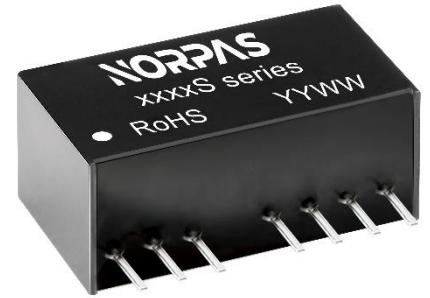

3 years  
Warranty

### Selection Guide

Part No.	Input Voltage (VDC)		Output		Full Load Efficiency% (Min./Typ.)	Capacitive Load Max. (μF)
	Nominal (Range)	Maximum	Voltage (VDC)	Current Max.(mA)		
ZYB2403S-10WR3	24 (9-36)	40	3.3	2400/0	83/85	2200
ZYB2405S-10WR3			5	2000/0	86/88	2200
ZYB2406S-10WR3			6	1667/0	86/88	1500
ZYB2412S-10WR3			12	833/0	86/88	470
ZYB2415S-10WR3			15	667/0	86/88	330
ZYB2424S-10WR3			24	417/0	86/88	220
ZYB4803S-10WR3	48 (18-75)	80	3.3	2400/0	82/84	2200
ZYB4805S-10WR3			5	2000/0	86/88	2200
ZYB4812S-10WR3			12	833/0	85/87	470
ZYB4815S-10WR3			15	667/0	84/86	330
ZYB4824S-10WR3			24	417/0	84/86	220

# each output

### Input Specifications

Item	Operating Conditions		Min.	Typ.	Max.	Unit
Input Current (full load/no load)	24VDC nominal input series, nominal input voltage	3.3VDC Output	--	389/25	398/45	mA
		5VDC Output	--	474/25	485/45	
		Other Output	--	474/9	485/18	
Reflected Ripple Current			--	50	--	
Impulse Voltage	24VDC Nominal Input Series		-0.7	--	50	VDC
Starting Voltage	24VDC Nominal Input Series		--	--	9	
Input Undervoltage Protection	24VDC Nominal Input Series		5.5	6.5	--	
Input Filter			Capacitance Filter			
Hot Plug			Unavailable			
CTRL	Module off		0-1.2V turn off			
	Module on		No connect or 3.5-12V on			

### Output Specifications

Item	Operating Conditions		Min.	Typ.	Max.	Unit
Output Voltage Accuracy	5% - 100% Load		--	±1.5	±2.0	%
Linear Regulation	Full load, Input voltage from low limit to high limit		--	±0.25	±0.5	
Load Regulation	5% - 100% Load		--	±0.5	±1.0	
Transient Recovery Time	25% load step change		--	0.3	0.5	ms
Transient Response Deviation		3.3VDC、5VDC	--	±5	±8	%
		Other Output	--	±3	±5	
Temperature Coefficient	Full Load		--	--	±0.03	%/°C
Ripple & Noise	20MHZ Bandwidth,5% - 100% Load		--	75	150	mVp-p
Overcurrent Protection	Input Voltage Range		110	160	230	%Io
Short-circuit Protection			Continuous, Self-Recovery			

### General Specifications

Item	Operating Conditions	Min.	Typ.	Max.	Unit
Insulation Voltage	Input-output, test time 1 minute, leakage current less than 1mA	1500	--	--	VDC
Insulation Resistance	Input-output, insulated voltage 500VDC	1000	--	--	MΩ
Isolation Capacitance	Input-output, 100KHz/0.1V	--	1000	--	pF
Operating Temperature	See Figure 1	-40	--	+85	°C
Storage Temperature		-55	--	+125	
Storage Humidity	Non-condensing	5	--	95	%RH
Pin welding can withstand the highest temperature	Soldering spot is 1.5mm away from case for 10 seconds	--	--	+300	°C
Switching Frequency	Full Load, Nominal Input Voltage	250	300	400	KHz
MTBF	MIL-HDBK-217F@25°C	>1000Kh			

### Mechanical Specifications

<b>Case Material</b>	Black plastic; flame-retardant and heat-resistant (UL 94V-0 rated)
<b>Package Dimensions</b>	22.00 * 12.00 * 9.50 mm
<b>Weight</b>	4.8g (Typ.)
<b>Cooling Method</b>	Free air convection

### EMC Specifications

<b>EMI</b>	CE	CISPR32/EN55032 CLASS B (The recommended circuit is shown in Figure 3-②)
	RE	CISPR32/EN55032 CLASS B (The recommended circuit is shown in Figure 3-②)
<b>EMS</b>	ESD	IEC/EN61000-4-2 Contact±4KV perf.Criteria B
	RS	IEC/EN61000-4-3 10V/m Perf.Criteria A
	EFT	IEC/EN61000-4-4 ±2KV (The recommended circuit is shown in Figure 3-①) Perf.Criteria B
	Surge	IEC/EN61000-4-5 line to line±2KV (The recommended circuit is shown in Figure 3-①) Perf.Criteria B
	CS	IEC/EN61000-4-6 3 Vr.m.s Perf.Criteria A

### Typical Characteristic Curves

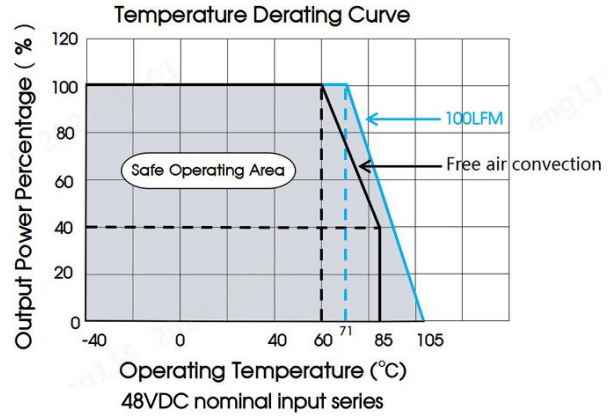
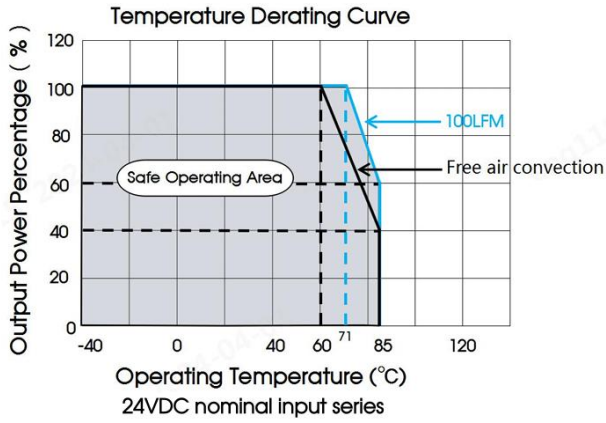
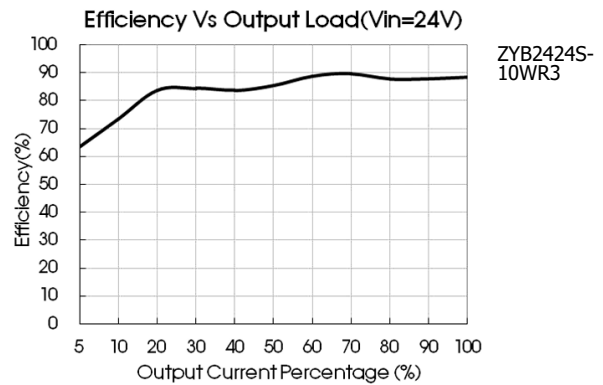
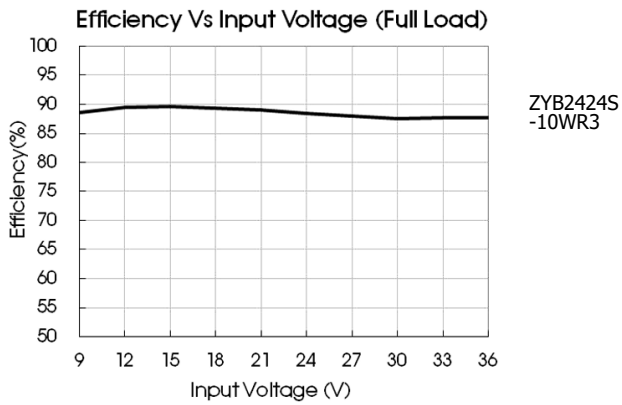
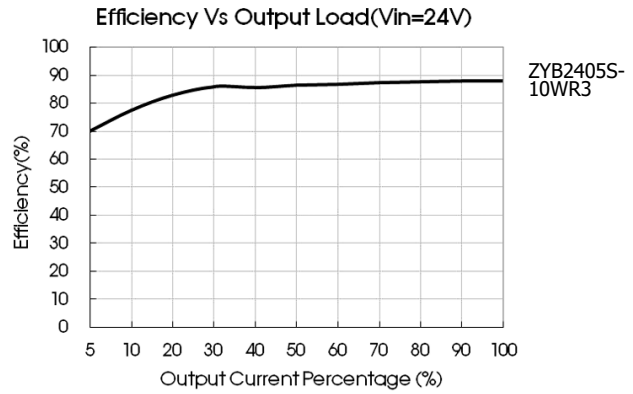
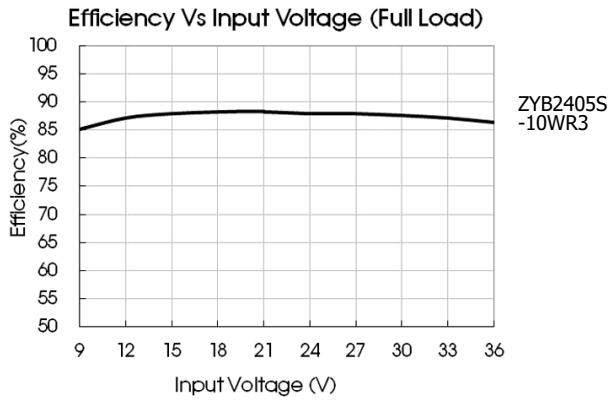

Fig. 1



### Circuit Design and Application

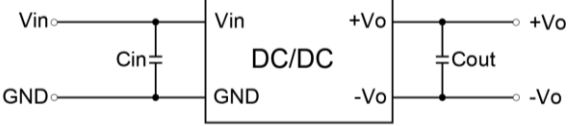

Figure 2

Recommended Capacitive Load Value Table		
Cin	Vout	Cout
47uF/100V	3.3/5/9	22uF/16V
	12/15	22uF/25V
	24	22uF/50V

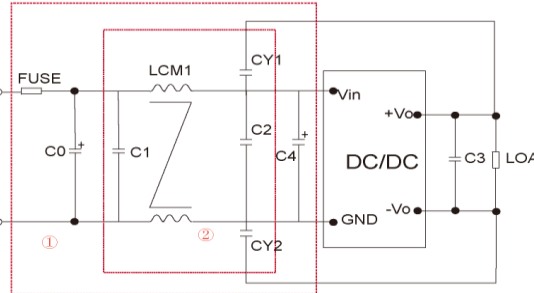

Figure 3

EMI Recommended Parameter Table	
Model	Vin:24V
FUSE	Select according to the actual input current of the customer
C0、C4	330uF/50V
C1、C2	10μF/50V
LCM1	470uH
C3	Refer to the Cout parameter in Figure 2
CY1、CY2	1nF/2000VDC

Note: Part 1 in Figure 3 is for EMC testing; The second part is used for EMI filtering, which can be selected according to the demand

**Note:**

1. The input voltage cannot exceed the specified range value, otherwise permanent and irreparable damage may be caused ;
2. Unless otherwise specified, the parameters in this datasheet were measured at 25°C, humidity 40%~75%, input nominal voltage and output pure resistance mode under full load;
3. All index test methods are based on our company's enterprise standards.

### Dimensions and Recommended Layout

#### Dimensions

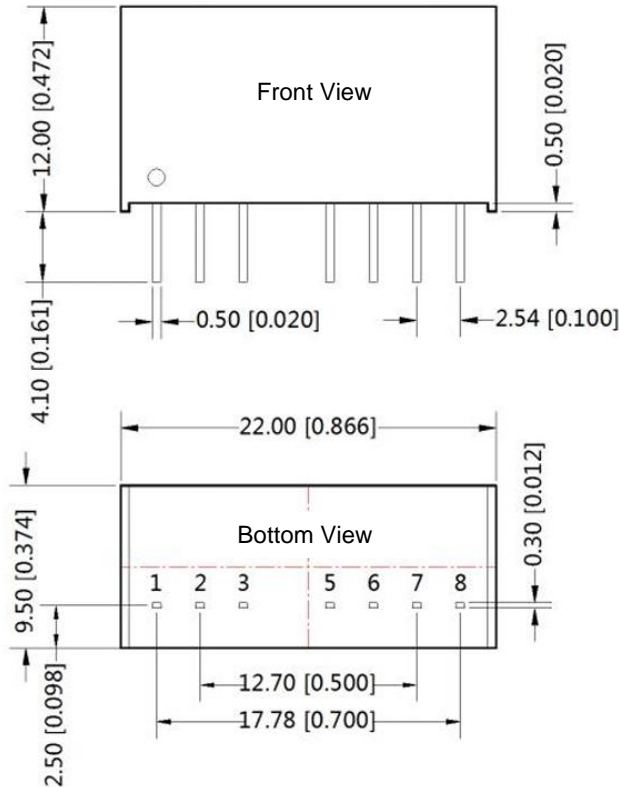

**Note:**

Unit: mm[inch]

Pin section tolerances:  $\pm 0.10[\pm 0.004]$

General tolerances:  $\pm 0.50[\pm 0.020]$

**Note:**

1. If the product works under the minimum required load, it cannot guarantee that the performance of the product complies with all the performance indicators in this manual;
2. The maximum capacitive load is tested under the input voltage range and full load condition;
3. Unless otherwise stated, all indexes in this manual are measured at  $T_a=25^\circ\text{C}$ , humidity  $<75\%RH$ , nominal input voltage and rated output load;
4. All index testing methods in this manual are based on the enterprise standards of the company;
5. Our company can provide product customization, specific needs can directly contact our technical staff;

#### PCB Printing Layout & Pin Definition Table

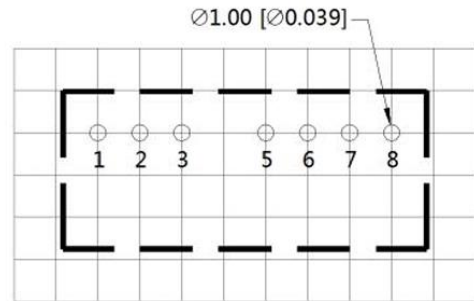

Note: The grid distance is 2.54mm\*2.54mm

Pin	Function (single)	Function (double)
1	GND	GND
2	Vin	Vin
3	CTRL	CTRL
5	NC	NC
6	+Vo	+Vo
7	0V	0V
8	CS	-Vo

NC: Cannot be connected to any electrical connection