

# High-Current Complementary Silicon Power Transistors

## MJ11028, MJ11030, MJ11032 (NPN) MJ11029, MJ11033 (PNP)

High-Current Complementary Silicon Power Transistors are for use as output devices in complementary general purpose amplifier applications.

### Features

- High DC Current Gain- $h_{FE} = 1000$  (Min) @  $I_C = 25$  Adc  
 $h_{FE} = 400$  (Min) @  $I_C = 50$  Adc
- Curves to 100 A (Pulsed)
- Diode Protection to Rated  $I_C$
- Monolithic Construction with Built-In Base-Emitter Shunt Resistor
- Junction Temperature to +200 °C
- Pb-Free Packages are Available\*

### MAXIMUM RATINGS ( $T_J = 25$ °C unless otherwise noted)

Rating	Symbol	Value	Unit
Collector-Emitter Voltage MJ11028/29 MJ11030 MJ11032/33	$V_{CEO}$	60 90 120	Vdc
Collector-Base Voltage MJ11028/29 MJ11030 MJ11032/33	$V_{CBO}$	60 90 120	Vdc
Emitter-Base Voltage	$V_{EBO}$	5.0	Vdc
Collector Current -Continuous -Peak (Note 1)	$I_C$	50 100	Aadc
Base Current - Continuous	$I_B$	2.0	Aadc
Total Power Dissipation @ $T_C = 25$ °C Derate Above 25 °C @ $T_C = 100$ °C	$P_D$	300 1.71	W W/°C
Operating and Storage Junction Temperature Range	$T_J, T_{stg}$	-55 to +200	°C

### THERMAL CHARACTERISTICS

Characteristic	Symbol	Max	Unit
Maximum Lead Temperature for Soldering Purposes for $\leq 10$ seconds	$T_L$	275	°C
Thermal Resistance, Junction-to-Case	$R_{\theta JC}$	0.58	°C/W

Stresses exceeding those listed in the Maximum Ratings table may damage the device. If any of these limits are exceeded, device functionality should not be assumed, damage may occur and reliability may be affected.

1. Pulse Test: Pulse Width = 5  $\mu$ s, Duty Cycle  $\leq 10\%$ .

\* For additional information on our Pb-Free strategy and soldering details, please download the **onsemi** Soldering and Mounting Techniques Reference Manual, [SOLDERM/D](#).

## 50 AMPERE COMPLEMENTARY DARLINGTON POWER TRANSISTORS 60-120 VOLTS 300 WATTS

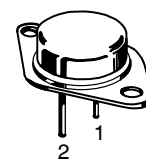
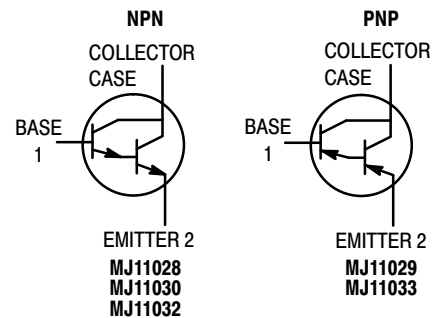

TO-204 (TO-3)  
CASE 197A  
STYLE 1

### MARKING DIAGRAM

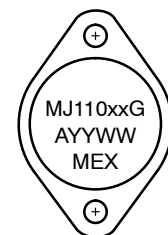

MJ110xx = Device Code  
xx = 28, 29, 30, 32, 33  
G = Pb-Free Package  
A = Location Code  
YY = Year  
WW = Work Week  
MEX = Country of Origin

### ORDERING INFORMATION

See detailed ordering and shipping information in the package dimensions section on page 3 of this data sheet.

## MJ11028, MJ11030, MJ11032 (NPN)

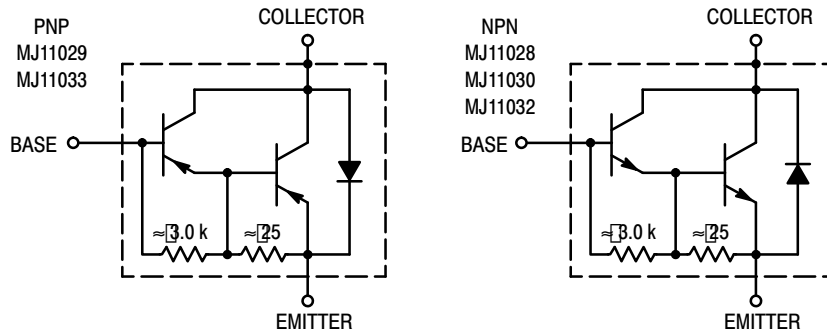

**Figure 1. Darlington Circuit Schematic**

### ELECTRICAL CHARACTERISTICS ( $T_C = 25^\circ\text{C}$ unless otherwise noted)

Characteristic	Symbol	Min	Max	Unit
<b>OFF CHARACTERISTICS</b>				
Collector–Emitter Breakdown Voltage (Note 1) ( $I_C = 1.00\text{ mAdc}$ , $I_B = 0$ ) MJ11032, MJ11033	$V_{(BR)CEO}$	60 90 120	– – –	Vdc
Collector–Emitter Leakage Current ( $V_{CE} = 60\text{ Vdc}$ , $R_{BE} = 1\text{ k}\Omega$ ) ( $V_{CE} = 90\text{ Vdc}$ , $R_{BE} = 1\text{ k}\Omega$ ) ( $V_{CE} = 120\text{ Vdc}$ , $R_{BE} = 1\text{ k}\Omega$ ) ( $V_{CE} = 60\text{ Vdc}$ , $R_{BE} = 1\text{ k}\Omega$ , $T_C = 150^\circ\text{C}$ ) ( $V_{CE} = 120\text{ Vdc}$ , $R_{BE} = 1\text{ k}\Omega$ , $T_C = 150^\circ\text{C}$ )	$I_{CER}$	– – – – –	2 2 2 10 10	mA <sub>dc</sub>
Emitter Cutoff Current ( $V_{BE} = 5\text{ Vdc}$ , $I_C = 0$ )	$I_{EBO}$	–	5	mA <sub>dc</sub>
Collector–Emitter Leakage Current ( $V_{CE} = 50\text{ Vdc}$ , $I_B = 0$ )	$I_{CEO}$	–	2	mA <sub>dc</sub>
<b>ON CHARACTERISTICS (Note 1)</b>				
DC Current Gain ( $I_C = 25\text{ Adc}$ , $V_{CE} = 5\text{ Vdc}$ ) ( $I_C = 50\text{ Adc}$ , $V_{CE} = 5\text{ Vdc}$ )	$h_{FE}$	1 k 400	18 k –	–
Collector–Emitter Saturation Voltage ( $I_C = 25\text{ Adc}$ , $I_B = 250\text{ mAdc}$ ) ( $I_C = 50\text{ Adc}$ , $I_B = 500\text{ mAdc}$ )	$V_{CE(sat)}$	– –	2.5 3.5	Vdc
Base–Emitter Saturation Voltage ( $I_C = 25\text{ Adc}$ , $I_B = 200\text{ mAdc}$ ) ( $I_C = 50\text{ Adc}$ , $I_B = 300\text{ mAdc}$ )	$V_{BE(sat)}$	– –	3.0 4.5	Vdc

1. Pulse Test: Pulse Width  $\leq 300\ \mu\text{s}$ , Duty Cycle  $\leq 2.0\%$ .

## MJ11028, MJ11030, MJ11032 (NPN)

### ORDERING INFORMATION

Device	Package	Shipping†
MJ11028G	TO-204 (Pb-Free)	100 Units / Tray
MJ11032G	TO-204 (Pb-Free)	100 Units / Tray
MJ11033G	TO-204 (Pb-Free)	100 Units / Tray

### DISCONTINUED (Note 2)

Device	Package	Shipping†
MJ11028	TO-204	100 Units / Tray
MJ11029	TO-204	100 Units / Tray
MJ11029G	TO-204 (Pb-Free)	100 Units / Tray
MJ11030	TO-204	100 Units / Tray
MJ11030G	TO-204 (Pb-Free)	100 Units / Tray
MJ11032	TO-204 (Pb-Free)	100 Units / Tray
MJ11033	TO-204	100 Units / Tray

† For information on tape and reel specifications, including part orientation and tape sizes, please refer to our Tape and Reel Packaging Specifications Brochure, [BRD8011/D](#)

\* NLV Prefix for Automotive and Other Applications Requiring Unique Site and Control Change Requirements; AEC-Q100 Qualified and PPAP Capable.

2. **DISCONTINUED:** This device is not available. Please contact your **onsemi** representative for information. The most current information on this device may be available on [www.onsemi.com](http://www.onsemi.com).

## MJ11028, MJ11030, MJ11032 (NPN)

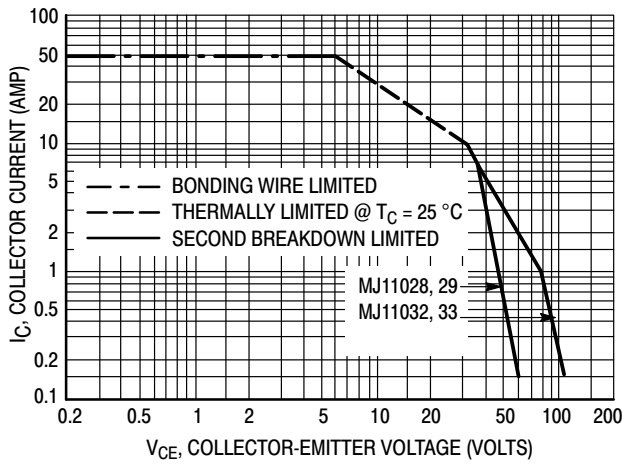

Figure 2. DC Safe Operating Area

There are two limitations on the power-handling ability of a transistor: average junction temperature and second breakdown. Safe operating area curves indicate  $I_C$ - $V_{CE}$  limits of the transistor that must be observed for reliable operation, i.e., the transistor must not be subjected to greater dissipation than the curves indicate.

The data of Figure 2 is based on  $T_{J(pk)} = 200\text{ °C}$ ;  $T_C$  is variable depending on conditions. At high case temperatures, thermal limitations will reduce the power that can be handled to values less than the limitations imposed by second breakdown.

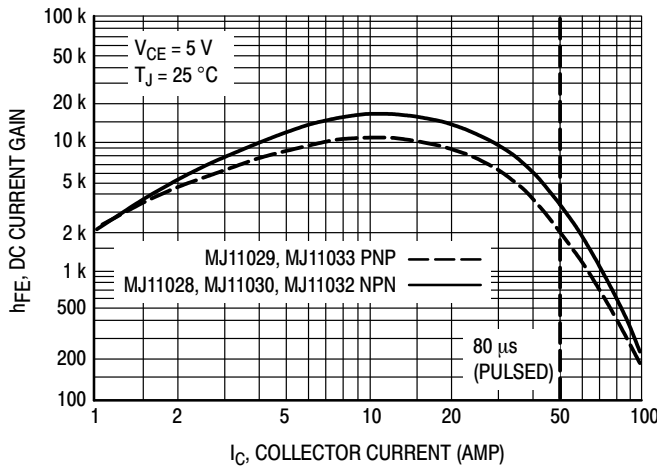

Figure 3. DC Current Gain

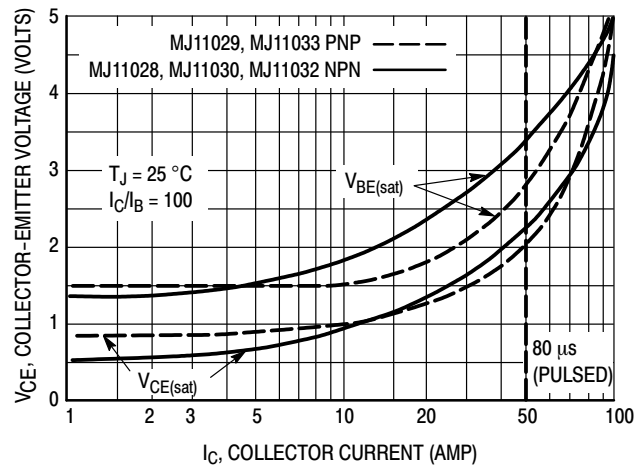

Figure 4. "On" Voltage

**MJ11028, MJ11030, MJ11032 (NPN)**

**REVISION HISTORY**

Revision	Description of Changes	Date
7	MJ11028, MJ11029, MJ11029G, MJ11030, MJ11030G, MJ11032, MJ11033, OPN Marked as Discontinued + Rebranded the Data Sheet to <b>onsemi</b> format	10/7/2025

This document has undergone updates prior to the inclusion of this revision history table. The changes tracked here only reflect updates made on the noted approval dates.

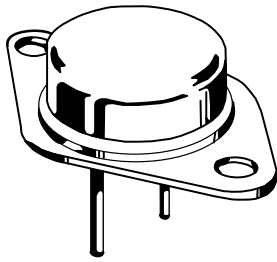

SCALE 1:1

TO-204 (TO-3)  
CASE 197A-05  
ISSUE K

DATE 21 FEB 2000

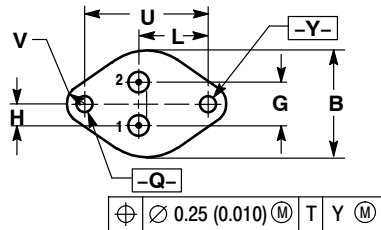
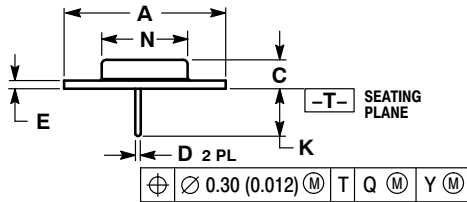

STYLE 1:  
PIN 1. BASE  
2. EMITTER  
CASE: COLLECTOR

STYLE 2:  
PIN 1. EMITTER  
2. BASE  
CASE: COLLECTOR

STYLE 3:  
PIN 1. GATE  
2. SOURCE  
CASE: DRAIN

STYLE 4:  
PIN 1. ANODE = 1  
2. ANODE = 2  
CASE: CATHODES

NOTES:  
1. DIMENSIONING AND TOLERANCING PER ANSI Y14.5M, 1982.  
2. CONTROLLING DIMENSION: INCH.

DIM	INCHES		MILLIMETERS	
	MIN	MAX	MIN	MAX
A	1.530 REF		38.86 REF	
B	0.990	1.050	25.15	26.67
C	0.250	0.335	6.35	8.51
D	0.057	0.063	1.45	1.60
E	0.060	0.070	1.53	1.77
G	0.430 BSC		10.92 BSC	
H	0.215 BSC		5.46 BSC	
K	0.440	0.480	11.18	12.19
L	0.665 BSC		16.89 BSC	
N	0.760	0.830	19.31	21.08
Q	0.151	0.165	3.84	4.19
U	1.187 BSC		30.15 BSC	
V	0.131	0.188	3.33	4.77

GENERIC  
MARKING DIAGRAM\*

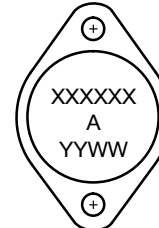

XXXXXX = Specific Device Code  
A = Assembly Location  
YY = Year  
WW = Work Week

\*This information is generic. Please refer to device data sheet for actual part marking. Pb-Free indicator, "G" or microdot "▪", may or may not be present. Some products may not follow the Generic Marking.

DOCUMENT NUMBER:	98ASB42129B	Electronic versions are uncontrolled except when accessed directly from the Document Repository. Printed versions are uncontrolled except when stamped "CONTROLLED COPY" in red.
DESCRIPTION:	TO-204 (TO-3)	PAGE 1 OF 1

onsemi and ONSEMI are trademarks of Semiconductor Components Industries, LLC dba onsemi or its subsidiaries in the United States and/or other countries. onsemi reserves the right to make changes without further notice to any products herein. onsemi makes no warranty, representation or guarantee regarding the suitability of its products for any particular purpose, nor does onsemi assume any liability arising out of the application or use of any product or circuit, and specifically disclaims any and all liability, including without limitation special, consequential or incidental damages. onsemi does not convey any license under its patent rights nor the rights of others.

**onsemi**, **Onsemi**, and other names, marks, and brands are registered and/or common law trademarks of Semiconductor Components Industries, LLC dba "**onsemi**" or its affiliates and/or subsidiaries in the United States and/or other countries. **onsemi** owns the rights to a number of patents, trademarks, copyrights, trade secrets, and other intellectual property. A listing of **onsemi**'s product/patent coverage may be accessed at [www.onsemi.com/site/pdf/Patent-Marking.pdf](http://www.onsemi.com/site/pdf/Patent-Marking.pdf). **onsemi** reserves the right to make changes at any time to any products or information herein, without notice. The information herein is provided "as-is" and **onsemi** makes no warranty, representation or guarantee regarding the accuracy of the information, product features, availability, functionality, or suitability of its products for any particular purpose, nor does **onsemi** assume any liability arising out of the application or use of any product or circuit, and specifically disclaims any and all liability, including without limitation special, consequential or incidental damages. Buyer is responsible for its products and applications using **onsemi** products, including compliance with all laws, regulations and safety requirements or standards, regardless of any support or applications information provided by **onsemi**. "Typical" parameters which may be provided in **onsemi** data sheets and/or specifications can and do vary in different applications and actual performance may vary over time. All operating parameters, including "Typicals" must be validated for each customer application by customer's technical experts. **onsemi** does not convey any license under any of its intellectual property rights nor the rights of others. **onsemi** products are not designed, intended, or authorized for use as a critical component in life support systems or any FDA Class 3 medical devices or medical devices with a same or similar classification in a foreign jurisdiction or any devices intended for implantation in the human body. Should Buyer purchase or use **onsemi** products for any such unintended or unauthorized application, Buyer shall indemnify and hold **onsemi** and its officers, employees, subsidiaries, affiliates, and distributors harmless against all claims, costs, damages, and expenses, and reasonable attorney fees arising out of, directly or indirectly, any claim of personal injury or death associated with such unintended or unauthorized use, even if such claim alleges that **onsemi** was negligent regarding the design or manufacture of the part. **onsemi** is an Equal Opportunity/Affirmative Action Employer. This literature is subject to all applicable copyright laws and is not for resale in any manner.

## ADDITIONAL INFORMATION

### TECHNICAL PUBLICATIONS:

Technical Library: [www.onsemi.com/design/resources/technical-documentation](http://www.onsemi.com/design/resources/technical-documentation)  
onsemi Website: [www.onsemi.com](http://www.onsemi.com)

### ONLINE SUPPORT: [www.onsemi.com/support](http://www.onsemi.com/support)

For additional information, please contact your local Sales Representative at [www.onsemi.com/support/sales](http://www.onsemi.com/support/sales)

