

# SPECIFICATION FOR APPROVAL

- ( ) Preliminary Specification
- (●) Final Specification

Title	86" QWUXGA TFT LCD
-------	--------------------

BUYER	General
MODEL	

SUPPLIER	LG Display Co., Ltd.
*MODEL	LD860EQN
SUFFIX	PMG2 (RoHS Verified)

APPROVED BY	SIGNATURE DATE
/	_____
/	_____
/	_____

APPROVED BY	SIGNATURE DATE
YoonSan Park/ Team Leader	_____
REVIEWED BY	SIGNATURE DATE
ByungJin Choi / Project Leader	_____
PREPARED BY	SIGNATURE DATE
YongDuk Lee / Engineer	_____

Please return 1 copy for your confirmation with your signature and comments.

**TV Product Development Dept.  
LG Display Co., Ltd.**

## Product Specification

**CONTENTS**

Number	ITEM	Page
	COVER	-
	CONTENTS	1
	RECORD OF REVISIONS	2
1	GENERAL DESCRIPTION	3
2	ABSOLUTE MAXIMUM RATINGS	4
3	ELECTRICAL SPECIFICATIONS	5
3-1	ELECTRICAL CHARACTERISTICS	5
3-2	INTERFACE CONNECTIONS	7
3-3	SIGNAL TIMING SPECIFICATIONS	11
3-4	V by One SIGNAL SPECIFICATIONS	12
3-5	COLOR DATA REFERENCE	14
3-6	POWER SEQUENCE	15
4	OPTICAL SPECIFICATIONS	17
5	MECHANICAL CHARACTERISTICS	21
6	RELIABILITY	24
7	INTERNATIONAL STANDARDS	25
7-1	SAFETY	25
7-2	ENVIRONMENT	25
8	PACKING	26
8-1	INFORMATION OF LCM LABEL	26
8-2	PACKING FORM	26
9	PRECAUTIONS	27
9-1	MOUNTING PRECAUTIONS	27
9-2	OPERATING PRECAUTIONS	27
9-3	ELECTROSTATIC DISCHARGE CONTROL	27
9-4	PRECAUTIONS FOR STRONG LIGHT EXPOSURE	27
9-5	STORAGE	27
9-6	APPROPRIATE CONDITION FOR COMMERCIAL DISPLAY	28



## Product Specification

## 1. General Description

The LD860EQN is a Color Active Matrix Liquid Crystal Display with an integral Light Emitting Diode (LED) backlight system. The matrix employs a-Si Thin Film Transistor as the active element.

It is a transmissive display type which is operating in the normally black mode. It has a 85.6 inch diagonally measured active display area with QWUXGA resolution (2160 vertical by 3840 horizontal pixel array).

Each pixel is divided into Red, Green and Blue sub-pixels or dots which are arrayed in vertical stripes.

Gray scale or the luminance of the sub-pixel color is determined with a 10-bit gray scale signal for each dot. Therefore, it can present a palette of more than 1.07Billion colors.

It has been designed to apply the 10-bit 8 Lane V by One interface.

It is intended to support LCD TV, PCTV where high brightness, super wide viewing angle, high color gamut, high color depth and fast response time are important.

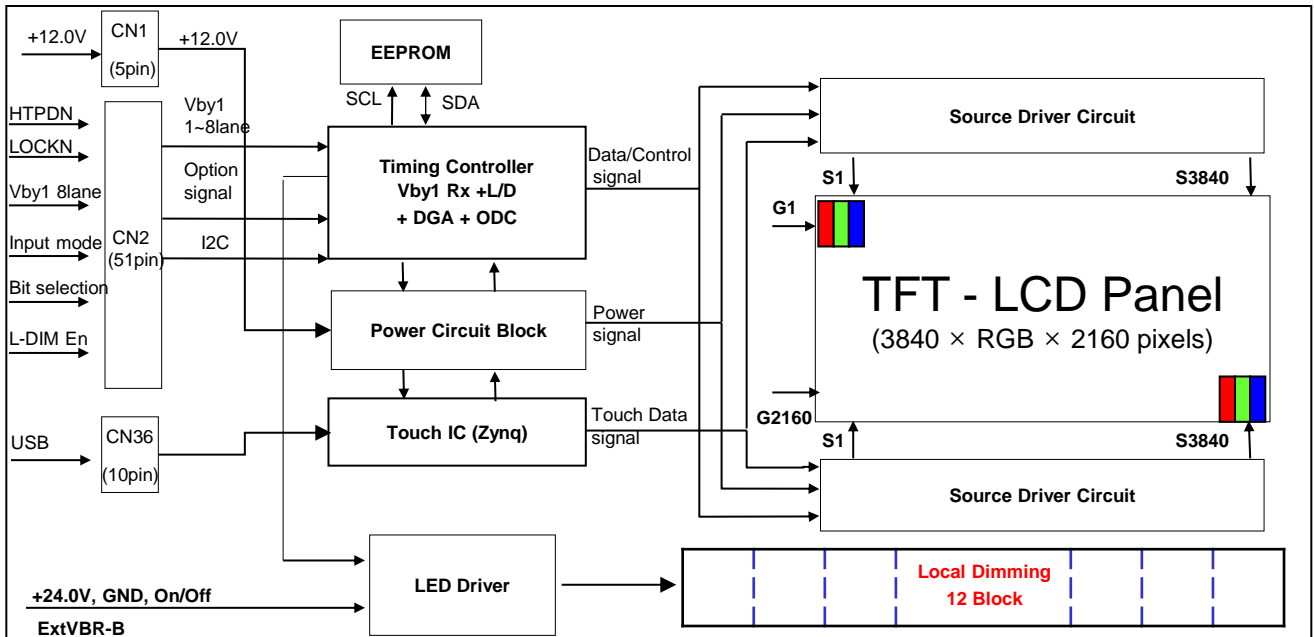

Active Screen Size	85.6 inches(2174.26 mm) diagonal
Outline Dimension	1945.0 (H) × 1116.0 (V) × 13.2 (B) (Typ.)
Pixel Pitch	0.4935 mm x 0.4935 mm
Pixel Format	3840 horiz. by 2160 vert. Pixels, RGB stripe arrangement
Display Mode	IPS
Color Depth	10bit(D), 1.07Billion colors
Interface	Vby1 8 Lane
Luminance, White	350cd/m <sup>2</sup> (Center 1point ,Typ.)
BLU Type	Edge type
Viewing Angle (CR>10)	Viewing angle free ( R/L 178 (Min.), U/D 178 (Min.))
Power Consumption	Total 278.1W (Typ.) - Logic= 44.7 (Typ.), 58.1W (Max.) - LED Driver=233.4W (ExtVbr_B=100%)(Typ.) , 249.4W (Max.)
Weight	47.0 Kg (Typ.) , 49.4Kg (Max.)
Display Mode	Transmissive mode, Normally black
Surface Treatment	Cover Glass, AG Coating
Possible Display Type	Landscape Only

## Product Specification

## 2. Absolute Maximum Ratings

The following items are maximum values which, if exceeded, may cause faulty operation or permanent damage to the LCD module.

**Table 1. ABSOLUTE MAXIMUM RATINGS**

Parameter		Symbol	Value		Unit	Notes	
			Min	Max			
Power Input Voltage	LCD Circuit	V <sub>LCD</sub>	-0.3	+14.0	V <sub>DC</sub>	1	
	Driver	V <sub>BL</sub>	-0.3	+ 27.0	V <sub>DC</sub>		
Driver Control Voltage	ON/OFF	V <sub>OFF</sub> / V <sub>ON</sub>	-0.3	+3.9	V <sub>DC</sub>		
	Brightness	EXTVBR-B	-0.3	+3.9	V <sub>DC</sub>		
	Status	Status	-0.3	+3.9	V <sub>DC</sub>		
T-Con Option Selection Voltage		V <sub>LOGIC</sub>	-0.3	+4.0	V <sub>DC</sub>		
Operating Temperature		T <sub>OP</sub>	0	+50	°C		2,3
Storage Temperature		T <sub>ST</sub>	-20	+60	°C		
Panel Front Temperature		T <sub>SUR</sub>	-	+68	°C	3	
Operating Ambient Humidity		H <sub>OP</sub>	10	90	%RH	2,3	
Storage Humidity		H <sub>ST</sub>	5	90	%RH		

- Ambient temperature condition ( $T_a = 25 \pm 2 \text{ }^\circ\text{C}$ )
- Temperature and relative humidity range are shown in the figure below.  
Wet bulb temperature should be Max 39°C, and no condensation of water.
- Gravity mura can be guaranteed below 40°C condition.
- The maximum operating temperatures is based on the test condition that the surface temperature of display area is less than or equal to 68°C with LCD module alone in a temperature controlled chamber. Thermal management should be considered in final product design to prevent the surface temperature of display area from being over 68°C. The range of operating temperature may be degraded in case of improper thermal management in final product design.

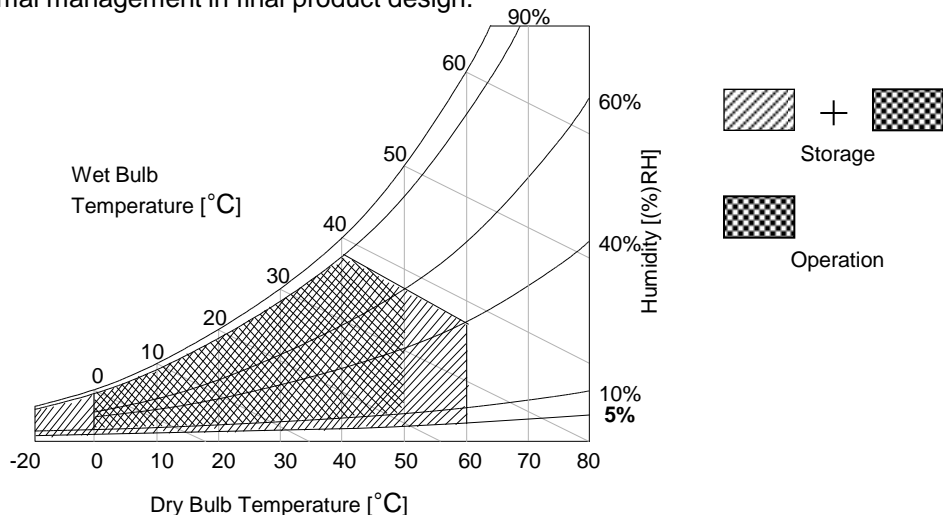

## Product Specification

### 3. Electrical Specifications

#### 3-1. Electrical Characteristics

It requires two power inputs. One is employed to power for the LCD circuit. The other is used for the LED backlight and LED Driver circuit.

**Table 2. ELECTRICAL CHARACTERISTICS**

Parameter	Symbol	Value			Unit	Note	
		Min	Typ	Max			
<b>Circuit :</b>							
Power Input Voltage	V <sub>LCD</sub>	10.8	12	13.2	VDC		
Power Input Current	I <sub>LCD</sub>	-	3720	4840	mA	1	
		-	4930	6410	mA	2	
T-CON Option Selection Voltage	Input High Voltage	V <sub>IH</sub>	2.7	-	3.6	VDC	
	Input Low Voltage	V <sub>IL</sub>	0	-	0.7	VDC	
Power Consumption	P <sub>LCD</sub>	-	44.7	58.1	Watt	1	
		-	59.2	77.0	Watt	2	
Rush current	I <sub>RUSH</sub>	-	-	70.0	A	3	

- Notes
1. The specified current and power consumption are under the  $V_{LCD}=12.0V$ ,  $T_a=25 \pm 2^\circ C$ ,  $f_v=60Hz$  condition, and mosaic pattern(8 x 6) is displayed and  $f_v$  is the frame frequency.
  2. The current is specified at the maximum current pattern.
  3. The duration of rush current is about 2ms and rising time of power input is 0.5ms (min.).
  4. Ripple voltage level is recommended under  $\pm 5\%$  of typical voltage

White : 1023 Gray  
Black : 0 Gray

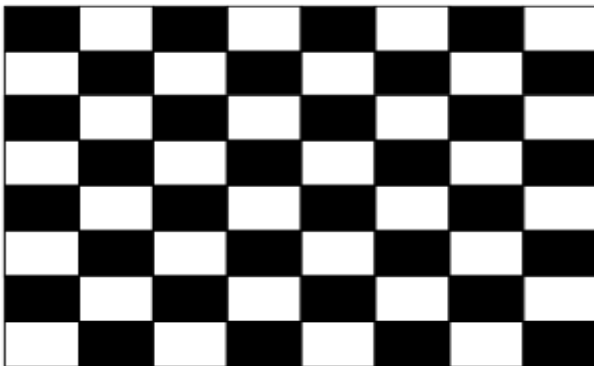

**Mosaic Pattern(8 x 6)**

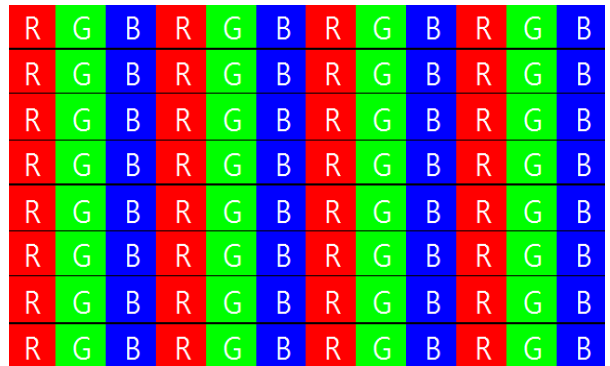

**Max Current Pattern**

## Product Specification

Table 3. ELECTRICAL CHARACTERISTICS (Continue)

Parameter	Symbol	Values			Unit	Notes	
		Min	Typ	Max			
LED Driver :							
Power Supply Input Voltage	VBL	21.6	24.0	26.4	Vdc	1	
Power Supply Input Current	IBL	-	9.7	10.4	A	1	
Power Supply Input Current (In-Rush)	In-rush	-	-	17.2	A	VBL = 21.6V ExtVBR-B=100% 3, 4	
Power Consumption (Total)	PBL	-	233.4	249.4	W	1	
Input Voltage for Control System Signals	On/Off	On	V on	2.5	-	3.6	Vdc
		Off	V off	-0.3	0.0	0.7	Vdc
	Brightness Adjust	ExtVBR-B	1	-	100	%	On Duty 5
	PWM Frequency	Frequency		120		Hz	2
	Pulse Duty Level (PWM)	HighLevel		2.5	-	3.6	Vdc
Low Level			0.0	-	0.7	Vdc	
LED :							
Life Time		30,000			Hrs		

## Notes :

- Electrical characteristics are determined after the unit has been 'ON' and stable for approximately 60 minutes at  $25 \pm 2^\circ\text{C}$ . The specified temperature, optical, and power consumption are under the typical supply input voltage 24V, current & VBR (ExtVBR-B : 100%), it is total power consumption.
- LGD recommend that the PWM freq. is synchronized with two time harmonic of V\_sync signal of system. Though PWM frequency is over 120Hz (max 252Hz), function of LED Driver is not affected.
- The duration of rush current is about 200ms. This duration is applied to LED on time
- Even though inrush current is over the specified value, there is no problem if I<sup>2</sup>T spec of fuse is satisfied.
- Ext\_PWM Signal have to input available duty range.  
Between 99% and 100% ExtVBR-B duty have to be avoided. ( $99\% < \text{ExtVBR-B} < 100\%$ )  
But ExtVBR-B 0% and 100% is possible.

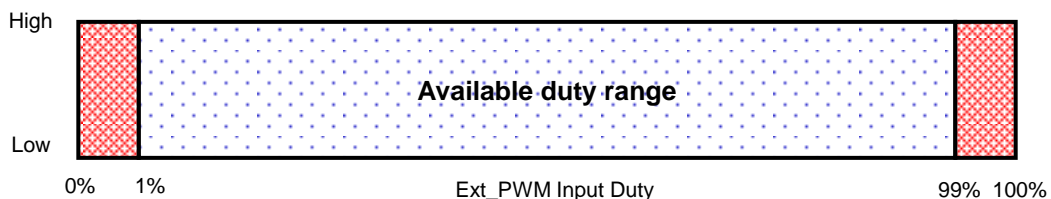

## Product Specification

## 3-2. Interface Connections

This LCD module employs three kinds of interface connection, 5pin (12V), 51pin (User CNT), 10pin (USB) connector are used for the module electronics.

### 3-2-1. LCD Module

- LCD Connector(CN1): 20037WR-H05 (manufactured by YEONHO)

**Table 3-1. MODULE CONNECTOR(CN1) PIN CONFIGURATION**

Pin No	Symbol	Description	Note
1	GND	Ground	
2	GND	Ground	
3	VLCD	Power Supply +12.0V	
4	VLCD	Power Supply +12.0V	
5	VLCD	Power Supply +12.0V	



## Product Specification

- LCD Connector(CN1): FI-RXE51S-HF (manufactured by JAE) or compatible
- Mating Connector : FI-R51HL(JAE) or compatible

**Table 3-2. MODULE CONNECTOR(CN2) PIN CONFIGURATION**

No	Symbol	Description	No	Symbol	Description
1	NC	No Connection(Notes 2)	27	GND	Ground
2	NC	No Connection(Notes 2)	28	Rx0n	V-by-One HS Data Lane 0
3	NC	No Connection(Notes 2)	29	Rx0p	V-by-One HS Data Lane 0
4	NC	No Connection(Notes 2)	30	GND	Ground
5	NC	No Connection(Notes 2)	31	Rx1n	V-by-One HS Data Lane 1
6	NC	No Connection(Notes 2)	32	Rx1p	V-by-One HS Data Lane 1
7	NC	No Connection(Notes 2)	33	GND	Ground
8	NC	No Connection(Notes 2)	34	Rx2n	V-by-One HS Data Lane 2
9	NC	No Connection	35	Rx2p	V-by-One HS Data Lane 2
10	GND	Ground	36	GND	Ground
11	GND	Ground	37	Rx3n	V-by-One HS Data Lane 3
12	GND	Ground	38	Rx3p	V-by-One HS Data Lane 3
13	GND	Ground	39	GND	Ground
14	NC	No Connection	40	Rx4n	V-by-One HS Data Lane 4
15	NC	No Connection	41	Rx4p	V-by-One HS Data Lane 4
16	NC	No Connection	42	GND	Ground
17	Input Mode	Vx1 Input Data Format 'L'=Non-Division , 'H'=2-Division	43	Rx5n	V-by-One HS Data Lane 5
18	SDA	SDA (I2C Data)	44	Rx5p	V-by-One HS Data Lane 5
19	SCL	SCL (I2C Clock)	45	GND	Ground
20	WP	I2C Write Protection	46	Rx6n	V-by-One HS Data Lane 6
21	Bit_SEL	'H' = 10bit , 'L' = 8bit	47	Rx6p	V-by-One HS Data Lane 6
22	LOCAL_ON	H' = Enable , 'L' or NC = Disable	48	GND	Ground
23	RBF	'H' : AGP(Default), 'L' : NSB (No signal Black)	49	Rx7n	V-by-One HS Data Lane 7
24	GND	Ground	50	Rx7p	V-by-One HS Data Lane 7
25	HTPDN	Hot plug detect	51	GND	Ground
26	LOCKN	Lock detect	-	-	-

- notes
1. All GND (ground) pins should be connected together to the LCD module's metal frame.
  2. #1~#8 NC (No connection) : These pins are used for back up power source, V<sub>LCD</sub>. (power input)  
These pins should be connected together.
  3. All Input levels of V-by-One signals are based on the V-by-One HS Standard Version 1.4.
  4. #14~#16, #18~#20, #22 NC (No Connection) : These pins are used only for LGD. (Do not connect)
  5. About specific pin (#17) , Please see the Appendix-VI.
  6. Specific pin No. #23 is used for "No signal detection" of system signal interface.  
It should be GND or NC for NSB (No Signal Black) while the system interface signal is not.  
If this pin is "H", LCD Module displays AGP. (Auto Generation Pattern)

## Product Specification

- LCD Connector(CN36) : 10031HR\_H10J, Au Plating (Yeonho)

**Table 3-3. MODULE CONNECTOR(CN36) PIN CONFIGURATION**

No	Symbol	Description
1	DP_2	USB(2) Data ( + ) for Touch
2	DM_2	USB(2) Data ( - ) for Touch
3	Ground	Ground
4	Ground	Ground
5	DP_1	USB(1) Data ( + ) for Touch
6	DM_1	USB(1) Data ( - ) for Touch
7	VBUS_1	Power for USB(1) interface (5V)
8	VBUS_1	Power for USB(1) interface (5V)
9	VBUS_2	Power for USB(2) interface (5V)
10	VBUS_2	Power for USB(2) interface (5V)

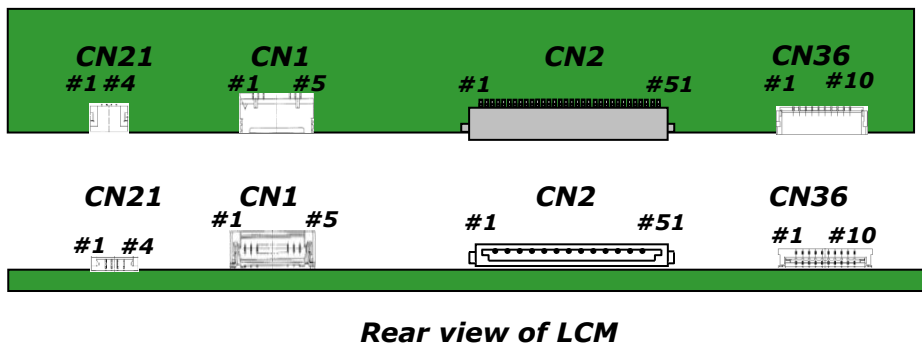

## Product Specification

## 3-2-2. Backlight Module

Master

- LED Driver Connector

: 20022WR-H14B2(Yeonho), 20022WR-H12B2(Yeonho)

Table 3-4. LED DRIVER CONNECTOR PIN CONFIGURATION

Pin No	Symbol	Description	14Pin	12Pin	Note
1	VBL	Power Supply +24.0V	VBL	VBL	
2	VBL	Power Supply +24.0V	VBL	VBL	
3	VBL	Power Supply +24.0V	VBL	VBL	
4	VBL	Power Supply +24.0V	VBL	VBL	
5	VBL	Power Supply +24.0V	VBL	VBL	
6	GND	Backlight Ground	GND	GND	1
7	GND	Backlight Ground	GND	GND	
8	GND	Backlight Ground	GND	GND	
9	GND	Backlight Ground	GND	GND	
10	GND	Backlight Ground	GND	GND	
11	Status	Backlight Status	Status	NC	2
12	VON/OFF	Backlight ON/OFF control	VON/OFF	NC	
13	NC	No Connection	NC	-	
14	EXTVBR_B	External PWM	EXTVBR_B	-	3

notes : 1. GND should be connected to the LCD module's metal frame.

2. Normal : Low (under 0.7V) / Abnormal : Open

3. High : on duty / Low : off duty, Pin#14 can be opened. ( if Pin #14 is open , EXTVBR-B is 100% )

4. Each impedance of pin #12 and 14 is over 50 [KΩ] .

## ◆ Rear view of LCM

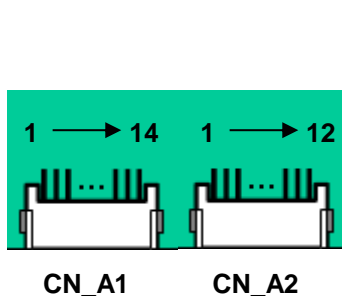

## ◆ Status

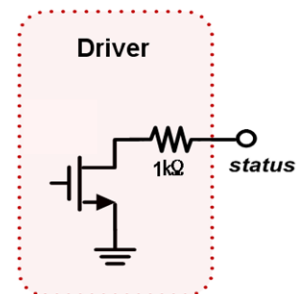
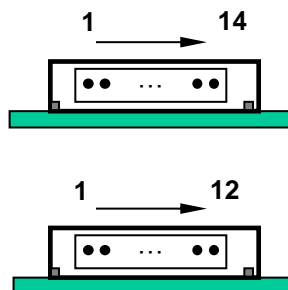

## Product Specification

### 3-3. Signal Timing Specifications

Table 4 shows the signal timing required at the input of the Vx1 transmitter. All of the interface signal timings should be satisfied with the following specification for normal operation.

**Table 4. TIMING TABLE (DE Only Mode)**

ITEM		Symbol	Min	Typ	Max	Unit	Note
Horizontal	Display Period	t <sub>HV</sub>	480	480	480	tCLK	3840/8
	Blank	t <sub>HB</sub>	79	79	79	tCLK	
	Total	t <sub>HP</sub>	559	559	559	tCLK	559 fix
Vertical	Display Period	t <sub>VV</sub>	2160	2160	2160	Lines	
	Blank	t <sub>VB</sub>	54	54	54	Lines	54 fix
	Total	t <sub>VP</sub>	2214	2214	2214	Lines	

ITEM		Symbol	Min	Typ	Max	Unit	Note
Frequency	DCLK	f <sub>CLK</sub>	73.8	74.25	74.7	MHz	594/8
	Horizontal	f <sub>H</sub>	132.02	132.83	133.63	KHz	2
	Vertical	f <sub>V</sub>	59.4	60	60.6	Hz	2

notes: 1. The input of HSYNC & VSYNC signal does not have an effect on normal operation (DE Only Mode).  
If you use spread spectrum of EMI, add some additional clock to minimum value for clock margin.

2. The performance of the electro-optical characteristics may be influenced by variance of the vertical refresh rate and the horizontal frequency.

※ Timing should be set based on clock frequency.

## Product Specification

## 3-4. V by One input signal Characteristics

## 3-4-1. V by One Input Signal Timing Diagram

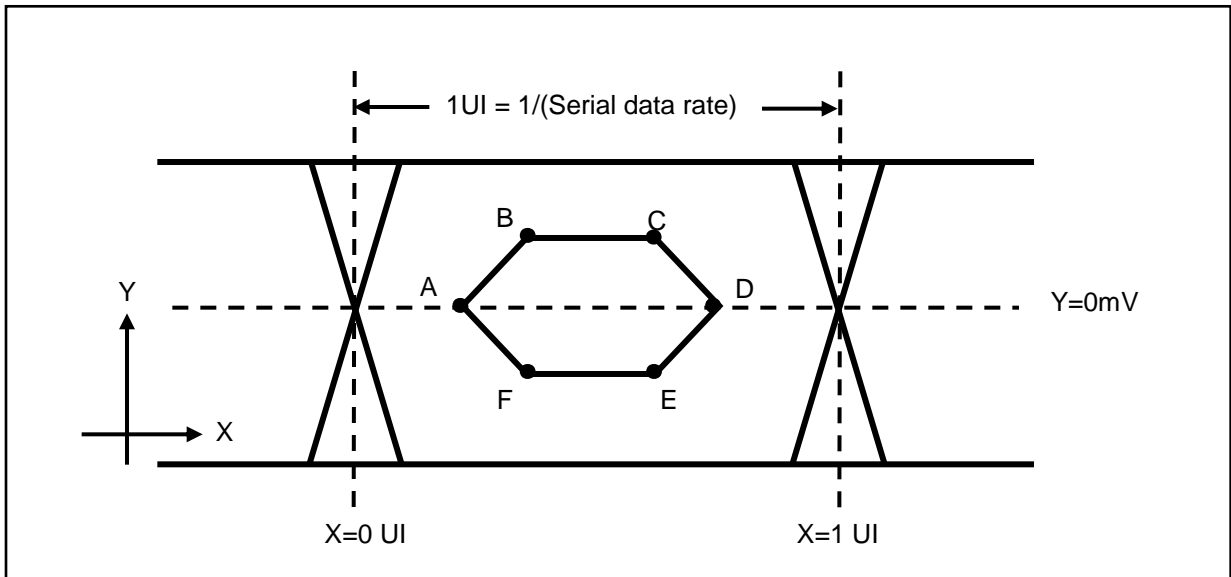

Table5. Eye Mask Specification

	X[UI]	Note	Y[mV]	Note
A	0.25 (max)	2	0	-
B	0.3 (max)	2	50	3
C	0.7(min)	3	50	3
D	0.75(min)	3	0	-
E	0.7(min)	3	1-50 I	3
F	0.3(max)	2	1-50 I	3

notes 1. All Input levels of V by One signals are based on the V by One HS Standard Ver. 1.4

2. This is allowable maximum value.

3. This is allowable minimum value.

4. The eye diagram is measured by the oscilloscope and receiver CDR characteristic must be emulated.

- PLL bandwidth : 15 Mhz

- Damping Factor : 1.51

## Product Specification

## 3-4-2. V by One Input Signal Characteristics

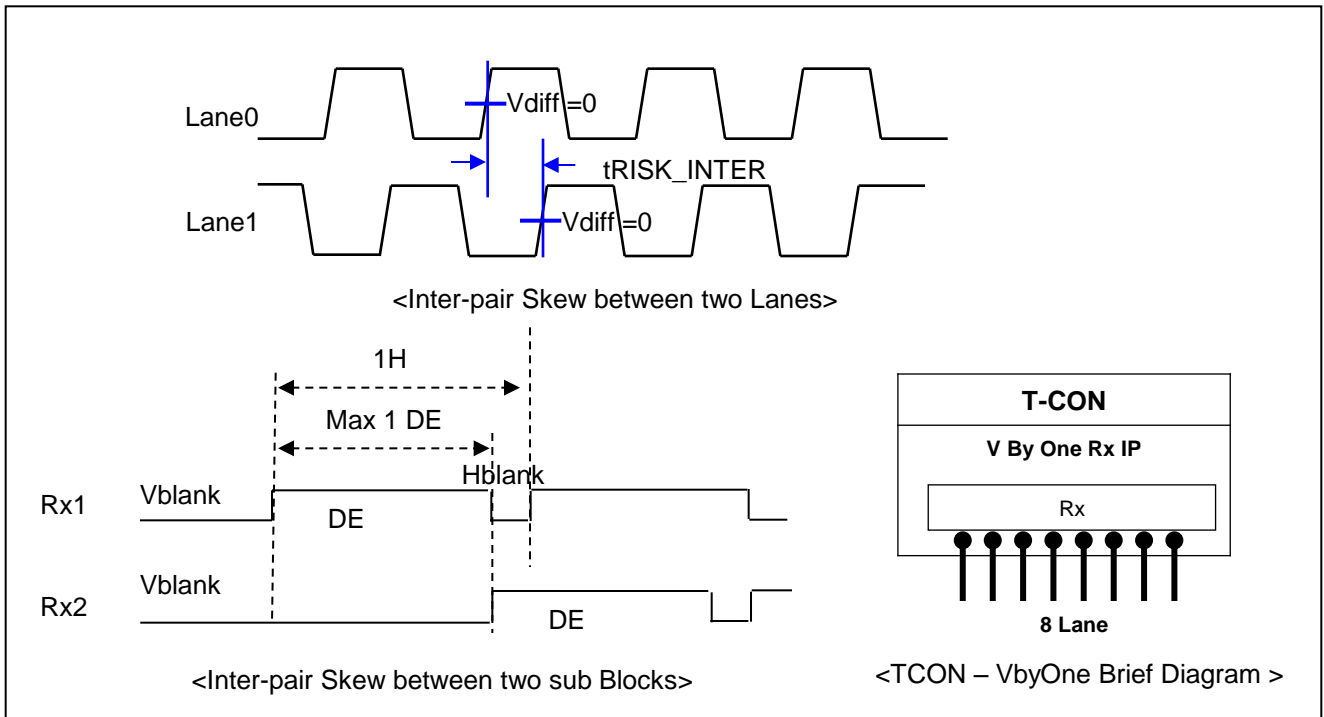

Description	Symbol	Min	Max	Unit	notes
Allowable inter-pair skew between lanes	$t_{RISK\_INTER}$	-	5	UI	1,2

Notes 1.  $1UI = 1/\text{serial data rate}$

2. it is the time difference of the differential voltage between any two lanes in one sub block.

## Product Specification

**3-5. Color Data Reference**

The brightness of each primary color (red, green, blue) is based on the 10bit or 8bit gray scale data input for the color. The higher binary input, the brighter the color. Table 8 provides a reference for color versus data input.

**Table 8. COLOR DATA REFERENCE**

Packer input & Unpacker output		30bpp RGB (10bit)	24bpp RGB (8bit)
Byte0	D[0]	R[2]	R[0]
	D[1]	R[3]	R[1]
	D[2]	R[4]	R[2]
	D[3]	R[5]	R[3]
	D[4]	R[6]	R[4]
	D[5]	R[7]	R[5]
	D[6]	R[8]	R[6]
	D[7]	R[9]	R[7]
Byte1	D[8]	G[2]	G[0]
	D[9]	G[3]	G[1]
	D[10]	G[4]	G[2]
	D[11]	G[5]	G[3]
	D[12]	G[6]	G[4]
	D[13]	G[7]	G[5]
	D[14]	G[8]	G[6]
	D[15]	G[9]	G[7]
Byte2	D[16]	B[2]	B[0]
	D[17]	B[3]	B[1]
	D[18]	B[4]	B[2]
	D[19]	B[5]	B[3]
	D[20]	B[6]	B[4]
	D[21]	B[7]	B[5]
	D[22]	B[8]	B[6]
	D[23]	B[9]	B[7]
Byte3	D[24]	Don't care	
	D[25]	Don't care	
	D[26]	B[0]	
	D[27]	B[1]	
	D[28]	G[0]	
	D[29]	G[1]	
	D[30]	R[0]	
	D[31]	R[1]	

Notes 1. 30bpp RGB (10bit) is 4 byte mode, otherwise (24bpp RGB) 3byte mode

## Product Specification

## 3-6. Power Sequence

## 3-6-1. LCD Driving circuit

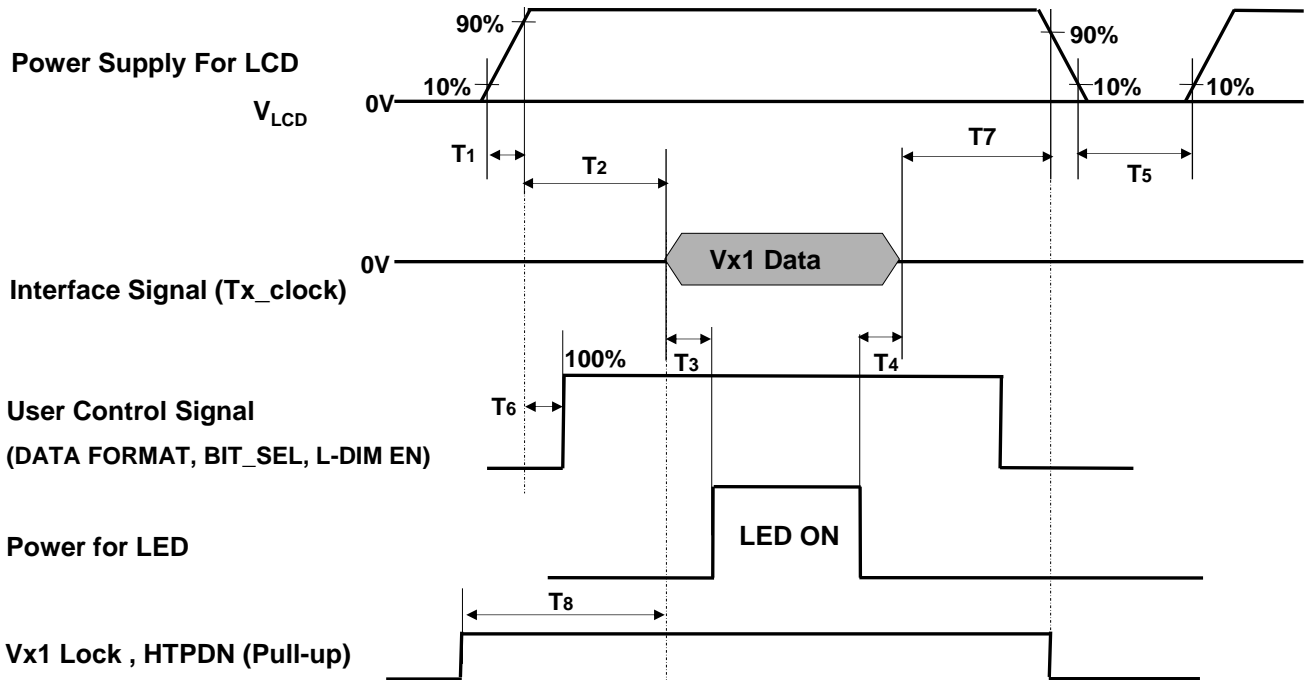

Parameter	Value			Unit	Note
	Min	Typ	Max		
T1	1.0	-	20	ms	1
T2	0	-	-	ms	2
T3	600	-	-	ms	3
T4	100	-	-	ms	3
T5	1.0	-	-	s	4
T6	0	-	T2	ms	5
T7	0	-	-	ms	6
T8	0	-	-	ms	

- Note :
1. Even though T1 is over the specified value, there is no problem if I2T spec of fuse is satisfied.
  2. If T2 is satisfied with specification after removing LVDS Cable, there is no problem.
  3. The T3 / T4 is recommended value, the case when failed to meet a minimum specification, abnormal display would be shown. There is no reliability problem.
  4. T5 should be measured after the Module has been fully discharged between power off and on period.
  5. If the on time of signals (Interface signal and user control signals) precedes the on time of Power ( $V_{LCD}$ ), it will be happened abnormal display. When T6 is NC status, T6 doesn't need to be measured.
  6. It is recommendation specification that T7 has to be 0ms as a minimum value.
    - ※ Please avoid floating state of interface signal at invalid period.
    - ※ When the power supply for LCD (VLCD) is off, be sure to pull down the valid and invalid data to 0V.



## Product Specification

## 3-6-2. Sequence for LED Driver

Power Supply For LED Driver

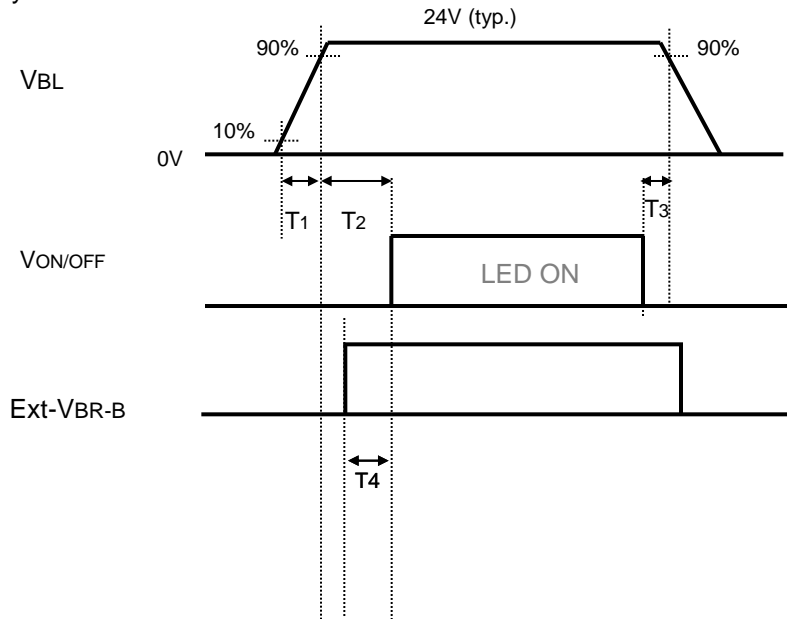

## 3-6-3. Dip condition for LED Driver

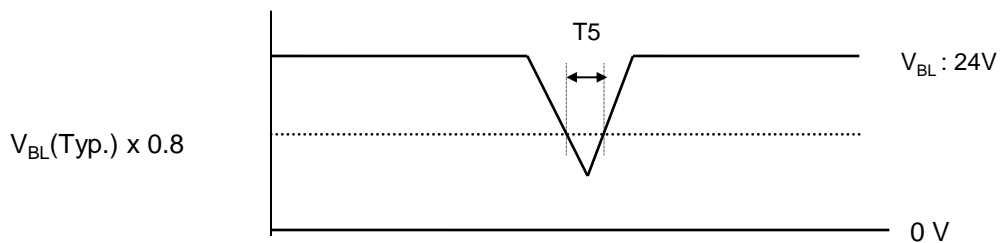

Table 10. Power Sequence for LED Driver

Parameter	Values			Units	Remarks
	Min	Typ	Max		
T1	20	-	-	ms	1
T2	500	-	-	ms	
T3	10	-	-	ms	
T4	0	-	-	ms	
T5	-	-	10	ms	$V_{BL}(Typ) \times 0.8$

notes : 1. T1 describes rising time of 0V to 24V and this parameter does not applied at restarting time.  
Even though T1 is over the specified value, there is no problem if I<sup>2</sup>T spec of fuse is satisfied.

## Product Specification

## 4. Optical Specification

Optical characteristics are determined after the unit has been 'ON' and stable in a dark environment at  $25\pm 2^{\circ}\text{C}$ . The values are specified at distance 50cm from the LCD surface at a viewing angle of  $\Phi$  and  $\theta$  equal to  $0^{\circ}$ .

FIG. 1 shows additional information concerning the measurement equipment and method.

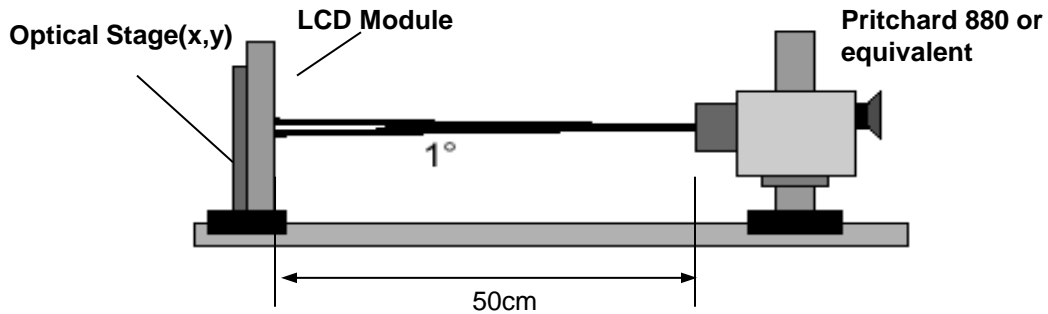

FIG. 1 Optical Characteristic Measurement Equipment and Method

$T_a = 25\pm 2^{\circ}\text{C}$ ,  $V_{\text{LCD}} = 12.0\text{V}$ ,  $f_v = 60\text{Hz}$ ,  $D_{\text{clk}} = 74.25\text{MHz}$ ,

$\text{EXTV}_{\text{BR-B}} = 100\%$

Table 11. OPTICAL CHARACTERISTICS

Parameter	Symbol	Value			Unit	notes	
		Min	Typ	Max			
Contrast Ratio	CR	750	1000	-		1	
Surface Luminance, white	$L_{\text{WH}}$	-	280	350	cd/m <sup>2</sup>	2	
Luminance Variation	$\delta_{\text{WHITE}}$	9P	60	70	%	3	
Response Time	Gray-to-Gray	G to G	-	8	12	ms	4
	Uniformity	$\delta_{\text{G TO G}}$	-	-	1		
Color Coordinates [CIE1931]	RED	Rx		0.645		2	
		Ry		0.331			
	GREEN	Gx		0.313			
		Gy	Typ	0.610	Typ		
	BLUE	Bx	-0.03	0.154	+0.03		
		By		0.055			
	WHITE	Wx		0.281			
Wy			0.288				
Color Temperature			10,000		K		
Color Gamut (NTSC)			72		%		
Viewing Angle (CR>10)							
	x axis, right ( $\phi=0^{\circ}$ )	$\theta_r$ (x axis)	89	-	-	degree	5
	x axis, left ( $\phi=180^{\circ}$ )	$\theta_l$ (x axis)	89	-	-		
	y axis, up ( $\phi=90^{\circ}$ )	$\theta_u$ (y axis)	89	-	-		
	y axis, down ( $\phi=270^{\circ}$ )	$\theta_d$ (y axis)	89	-	-		
Gray Scale			-	-	-		6

## Product Specification

notes : 1. Contrast Ratio(CR) is defined mathematically as :

$$\text{Contrast Ratio} = \frac{\text{Surface Luminance with all white pixels}}{\text{Surface Luminance with all black pixels}}$$

It is measured at center 1-point.

2. Optical Characteristics is determined after the unit has been 'ON' and 1 Hour after lighting the backlight in a dark environment at  $25 \pm 2^\circ\text{C}$ . Surface luminance is the luminance value at center 1-point across the LCD surface 50cm from the surface with all pixels displaying white. For more information see the FIG. 2
3. The variation in surface luminance,  $\delta$  WHITE is defined as :  
 $\delta$  WHITE(9P) = Minimum (Lon1, Lon2~ Lon8, Lon9) / Maximum (Lon1, Lon2~ Lon8, Lon9)\*100  
 Where Lon1 to Lon9 are the luminance with all pixels displaying white at 9 locations
4. Response time is the time required for the display to transit from G(N) to G(M) (Rise Time,  $T_{rR}$ ) and from G(M) to G(N) (Decay Time,  $T_{rD}$ ). For additional information see the FIG. 3. (N<M)  
 ※ G to G Spec stands for average value of all measured points.  
 Photo Detector : RD-80S / Field :  $2^\circ$   
 ※ . Gray to Gray Response time uniformity is Reference data. Appendix VI-1.
5. Viewing angle is the angle at which the contrast ratio is greater than 10. The angles are determined for the horizontal or x axis and the vertical or y axis with respect to the z axis which is normal to the LCD module surface. For more information, see the FIG. 4.
6. Gray scale specification  
 Gamma Value is approximately 2.2. For more information, see the Table 12.

**Table 12. GRAY SCALE SPECIFICATION**

Gray Level	Luminance [%] (Typ)
L0	<b>0.10</b>
L63	0.27
L127	1.04
L191	2.49
L255	4.68
L319	7.66
L383	11.5
L447	16.1
L511	21.6
L575	28.1
L639	35.4
L703	43.7
L767	53.0
L831	63.2
L895	74.5
L959	86.7
L1023	100

## Product Specification

Measuring point for surface luminance & measuring point for luminance variation.

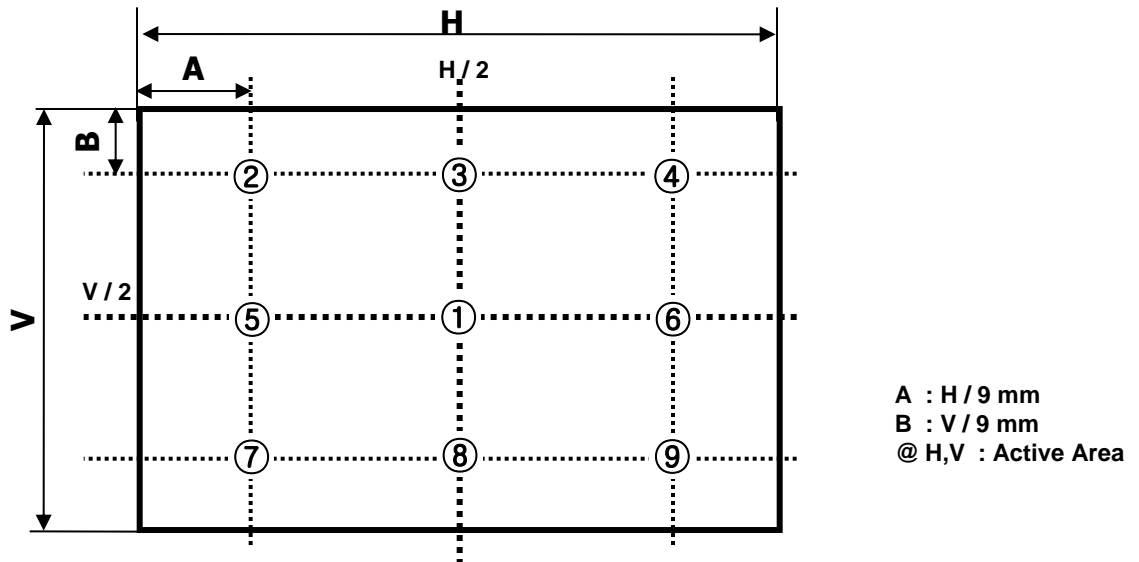

FIG. 2 9 Points for Luminance Measure

Response time is defined as the following figure and shall be measured by switching the input signal for “Gray(N)” and “Gray(M)”.

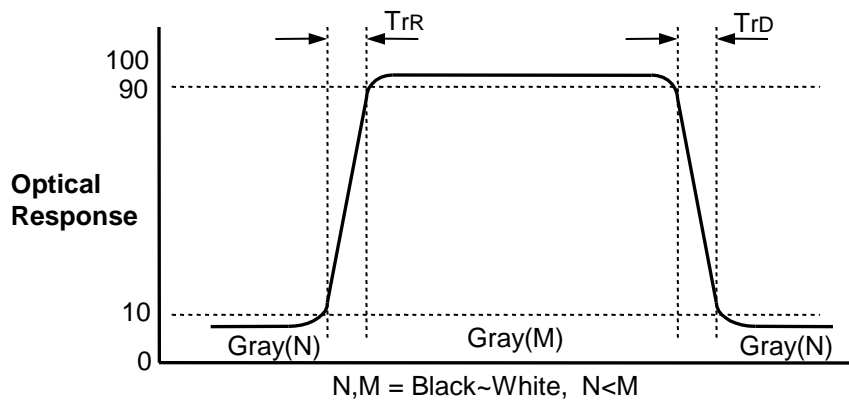
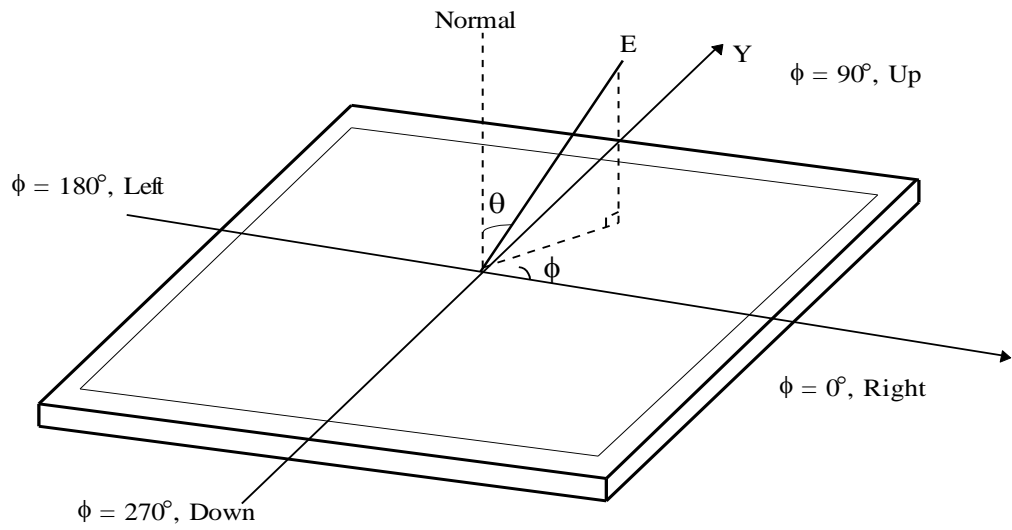

FIG. 3 Response Time

Dimension of viewing angle range



**FIG. 4 Viewing Angle**

## Product Specification

## 5. Mechanical Characteristics

Table 13 provides general mechanical characteristics.

**Table 13. MECHANICAL CHARACTERISTICS**

Item	Value	
Outline Dimension	Horizontal	1945.0 mm
	Vertical	1116.0 mm
	Depth	13.2mm(B)
Bezel Area	Horizontal	25mm
	Vertical	25mm
Active Display Area	Horizontal	1895.04 mm
	Vertical	1065.96 mm
Weight	<b>47.0 kg (Typ), 49.4Kg(Max)</b>	

notes : Please refer to a mechanical drawing in terms of tolerance at the next page.

Product Specification

[ FRONT VIEW ]

SET : TOP

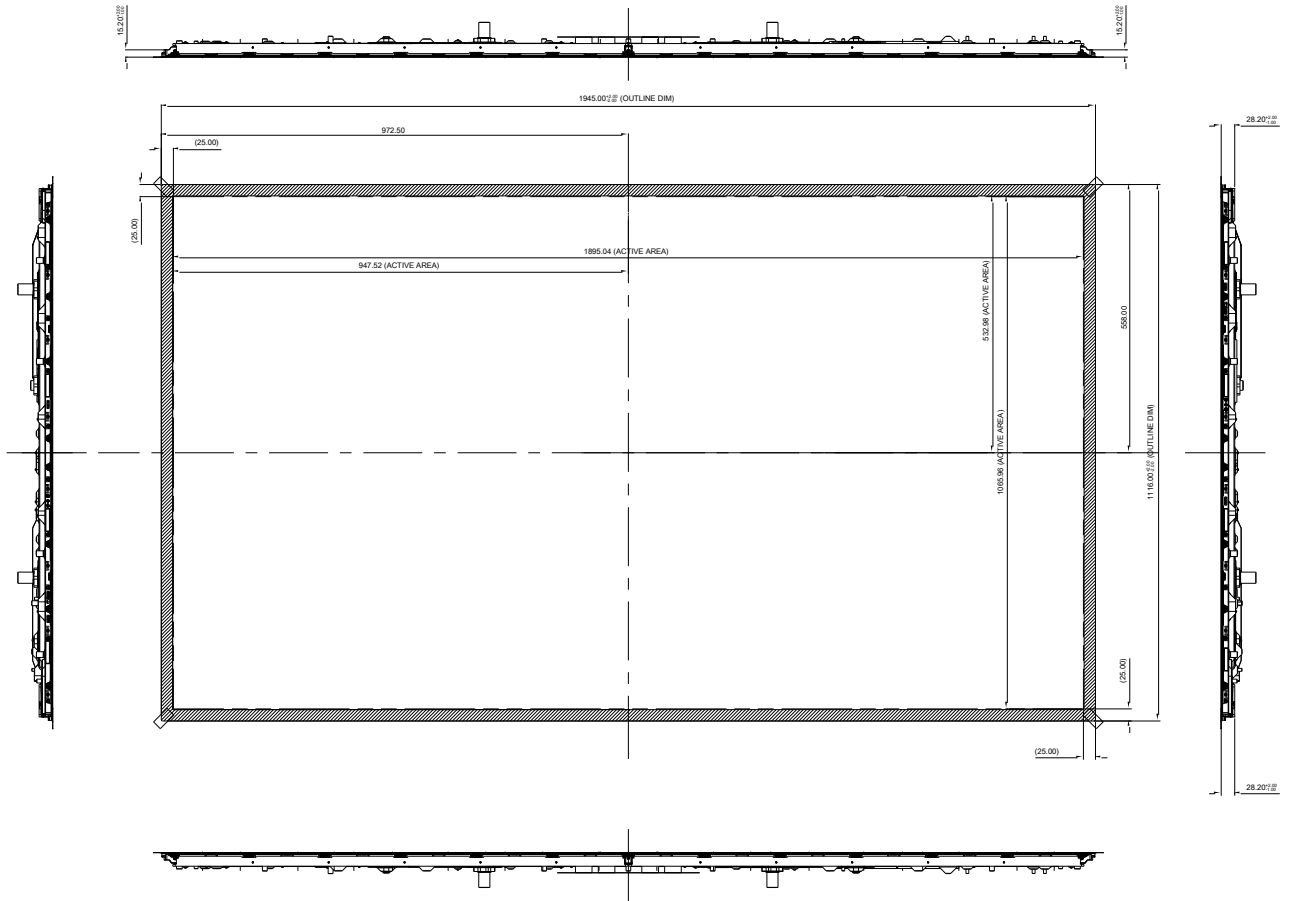

SET : DOWN

## Product Specification

[ REAR VIEW ]

SET : TOP

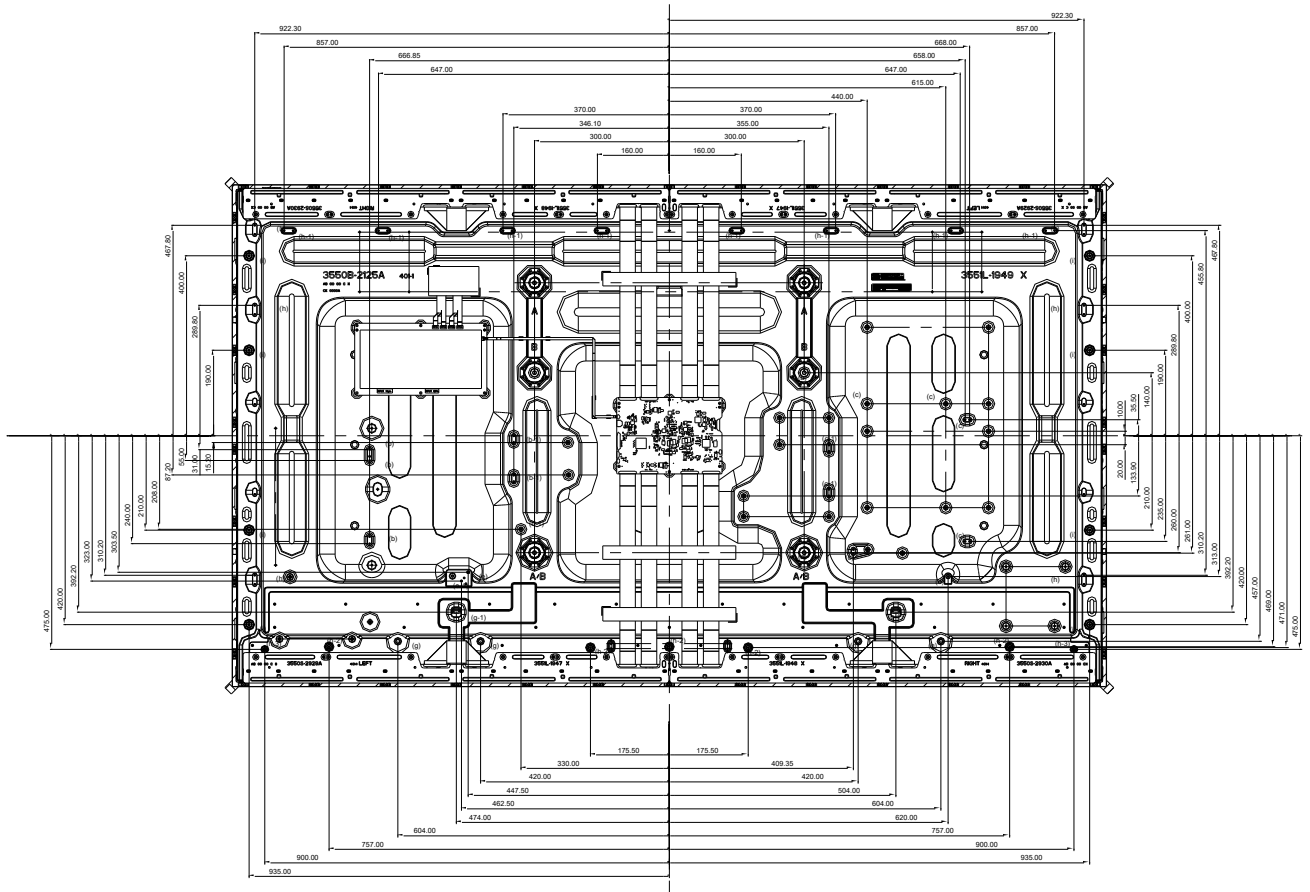

SET : DOWN

## NOTES

1. UNSPECIFIED TOLERANCE IS ` 1.0mm.
2. MAX TORQUE : REFER TO TABLE.
3. MAX DEPTH (SCREW) : REFER TO TABLE.
4. THE WEIGHT OF LCM IS 47.0kg (TYP.), 49.4kg (MAX.).
5. THE SAME REATURE MEANS THE SAME DIMENSION.

ITEM	TYPE	UDM HEIGHT (mm)	MAX DEPTH (mm)	MAX TORQUE (kgf.cm)	NOTES
(a)	M8.0	17.9	11.0	8.0	VESA
(b)	M3.0	4.8	4.5	5.0	PSU
(b-1)	M3.0	6.0	5.7	5.0	(Bracket)
(c)	M3.0	7.0	6.7	5.0	MAIN BOARD
(c-1)	M3.0	6.0	5.7	5.0	(Bracket)
(d)	M3.0	14.6	9.8	5.0	BACKCOVER
(e)	M3.0	9.0	5.5	5.0	POWER CABLE
(e-1)	M4.0	15.7	4.5	5.0	
(g)	n 8.0 (Burring)	16.6	16.3	-	SPEAKER
(g-1)	-	10.8	-	-	
(h)	M3.0	15.0	14.7	5.0	MIDDLE CABINET
(h-1)	M3.0	2.0	1.7	5.0	(Bracket)
(h-2)	M3.0	16.6	9.8	5.0	
(h-3)	M3.0	11.8	6.0	5.0	
(i)	M4.0	18.6	14.1	5.0	HANDLE



## Product Specification

**6. Reliability****Table 14. ENVIRONMENT TEST CONDITION**

No.	Test Item	Condition
1	High temperature storage test	Ta= 60°C 90% 240h
2	Low temperature storage test	Ta= -20°C 240h
3	High temperature operation test	Ta= 50°C 50%RH 500h
4	Low temperature operation test	Ta= 0°C 500h
5	Humidity condition Operation	Ta= 40 °C ,90%RH
6	Altitude operating storage / shipment	0 - 16,400 ft 0 - 40,000 ft

Note : 1. Before and after Reliability test, LCM should be operated with normal function.

2. These conditions are for LGD's internal test. Please refer to Absolute Maximum Ratings (Table1) for guaranteed condition.

## 7. International Standards

### 7-1. Safety

- a) UL 60065, Underwriters Laboratories Inc.  
Audio, Video and Similar Electronic Apparatus - Safety Requirements.
- b) CAN/CSA C22.2 No.60065:03, Canadian Standards Association.  
Audio, Video and Similar Electronic Apparatus - Safety Requirements.
- c) EN 60065, European Committee for Electrotechnical Standardization (CENELEC).  
Audio, Video and Similar Electronic Apparatus - Safety Requirements.
- d) IEC 60065, The International Electro technical Commission (IEC).  
Audio, Video and Similar Electronic Apparatus - Safety Requirements.

### 7-2. Environment

- a) RoHS, Directive 2011/65/EU of the European Parliament and of the council of 8 June 2011

## Product Specification

**8. Packing****8-1. Information of LCM Label**

a) Lot Mark

A	B	C	D	E	F	G	H	I	J	K	L	M
---	---	---	---	---	---	---	---	---	---	---	---	---

A,B,C : SIZE(INCH)  
E : MONTH

D : YEAR  
F ~ M : SERIAL NO.

Note

1. YEAR

Year	2011	2012	2013	2014	2015	2016	2017	2018	2019	2020
Mark	A	B	C	D	E	F	G	H	J	K

2. MONTH

Month	Jan	Feb	Mar	Apr	May	Jun	Jul	Aug	Sep	Oct	Nov	Dec
Mark	1	2	3	4	5	6	7	8	9	A	B	C

b) Location of Lot Mark

Serial NO. is printed on the label. The label is attached to the backside of the LCD module.  
This is subject to change without prior notice.

**8-2. Packing Form**

a) Package quantity in one Pallet : 7 pcs

b) Pallet Size : 2280 mm(W) X 780 mm(D) X 1450 mm(H)

## Product Specification

### 9. Precautions

Please pay attention to the followings when you use this TFT LCD module.

#### 9-1. Mounting Precautions

- (1) You must mount a module using specified mounting holes (Details refer to the drawings).
- (2) You should consider the mounting structure so that uneven force (ex. Twisted stress, Concentrated stress) is not applied to the module. And the case on which a module is mounted should have sufficient strength so that external force is not transmitted directly to the module.
- (3) Please attach the surface transparent protective plate to the surface in order to protect the polarizer. Transparent protective plate should have sufficient strength in order to resist external force.
- (4) You should adopt radiation structure to satisfy the temperature specification.
- (5) Acetic acid type and chlorine type materials for the cover case are not desirable because the former generates corrosive gas of attacking the polarizer at high temperature and the latter causes circuit break by electro-chemical reaction.
- (6) Do not touch, push or rub the exposed polarizers with glass, tweezers or anything harder than HB pencil lead. And please do not rub with dust clothes with chemical treatment. Do not touch the surface of polarizer for bare hand or greasy cloth. (Some cosmetics are detrimental to the polarizer.)
- (7) When the surface becomes dusty, please wipe gently with absorbent cotton or other soft materials like chamois soaks with petroleum benzine. Normal-hexane is recommended for cleaning the adhesives used to attach front / rear polarizers. Do not use acetone, toluene and alcohol because they cause chemical damage to the polarizer
- (8) Wipe off saliva or water drops as soon as possible. Their long time contact with polarizer causes deformations and color fading.
- (9) Do not open the case because inside circuits do not have sufficient strength.
- (10) Touching the LED Driver might cause an electric shock and damage to LED Driver. Please always use antistatic tools when handling the LED Driver

#### 9-2. Operating Precautions

- (1) Response time depends on the temperature. (In lower temperature, it becomes longer.)
- (2) Brightness depends on the temperature. (In lower temperature, it becomes lower.)  
And in lower temperature, response time (required time that brightness is stable after turned on) becomes longer
- (3) Be careful for condensation at sudden temperature change. Condensation makes damage to polarizer or electrical contacted parts. And after fading condensation, smear or spot will occur.
- (4) When fixed patterns are displayed for a long time, remnant image is likely to occur.
- (5) Module has high frequency circuits. Sufficient suppression to the electromagnetic interference shall be done by system manufacturers. Grounding and shielding methods may be important to minimize the interference.
- (6) Please do not give any mechanical and/or acoustical impact to LCM. Otherwise, LCM can't be operated its full characteristics perfectly.
- (7) A screw which is fastened up the steels should be a machine screw.  
(if not, it can cause conductive particles and deal LCM a fatal blow)
- (8) Please do not set LCD on its edge.
- (9) The conductive material and signal cables are kept away from LED driver inductor to prevent abnormal display, sound noise and temperature rising.

### 9-3. Electrostatic Discharge Control

Since a module is composed of electronic circuits, it is not strong to electrostatic discharge. Make certain that treatment persons are connected to ground through wrist band etc. And don't touch interface pin directly.

### 9-4. Precautions for Strong Light Exposure

Strong light exposure causes degradation of polarizer and color filter.

### 9-5. Storage

When storing modules as spares for a long time, the following precautions are necessary.

- (1) Store them in a dark place. Do not expose the module to sunlight or fluorescent light. Keep the temperature between 5°C and 35°C at normal humidity.
- (2) The polarizer surface should not come in contact with any other object.  
It is recommended that they be stored in the container in which they were shipped.
- (3) Storage condition is guaranteed under packing conditions.
- (4) The phase transition of Liquid Crystal in the condition of the low or high storage temperature will be recovered when the LCD module returns to the normal condition.

### 9-6. Appropriate Condition for Commercial Display

- Generally large-sized LCD modules are designed for consumer applications (TV).

Accordingly, a long-term display like in Commercial Display application, can cause uneven display including image sticking. To optimize module's lifetime and function, several operating usages are required.

#### 1. Normal operating condition

- Temperature: 0 ~ 40°C
  - Operating Ambient Humidity : 10 ~ 90 %
  - Display pattern: dynamic pattern (Real display)
- Note) Long-term static display can cause image sticking.

#### 2. Operating usages under abnormal condition

##### a. Ambient condition

- Well-ventilated place is recommended to set up Commercial Display system.

##### b. Power and screen save

- Periodical power-off or screen save is needed after long-term display.

## Product Specification

3. Operating usages to protect against image sticking due to long-term static display
  - a. Suitable operating time: under 18 hours a day.
  - b. Static information display recommended to use with moving image.
    - Cycling display between 5 minutes' information(static) display and 10 seconds' moving image.
  - c. Background and character (image) color change
    - Use different colors for background and character, respectively.
    - Change colors themselves periodically.
  - d. Avoid combination of background and character with large different luminance.
    - 1) Abnormal condition just means conditions except normal condition.
    - 2) Black image or moving image is strongly recommended as a screen save.
4. Lifetime in this spec. is guaranteed only when Commercial Display is used according to operating usages.

## Product Specification

## # APPENDIX-I

## ■ Pallet Ass'y

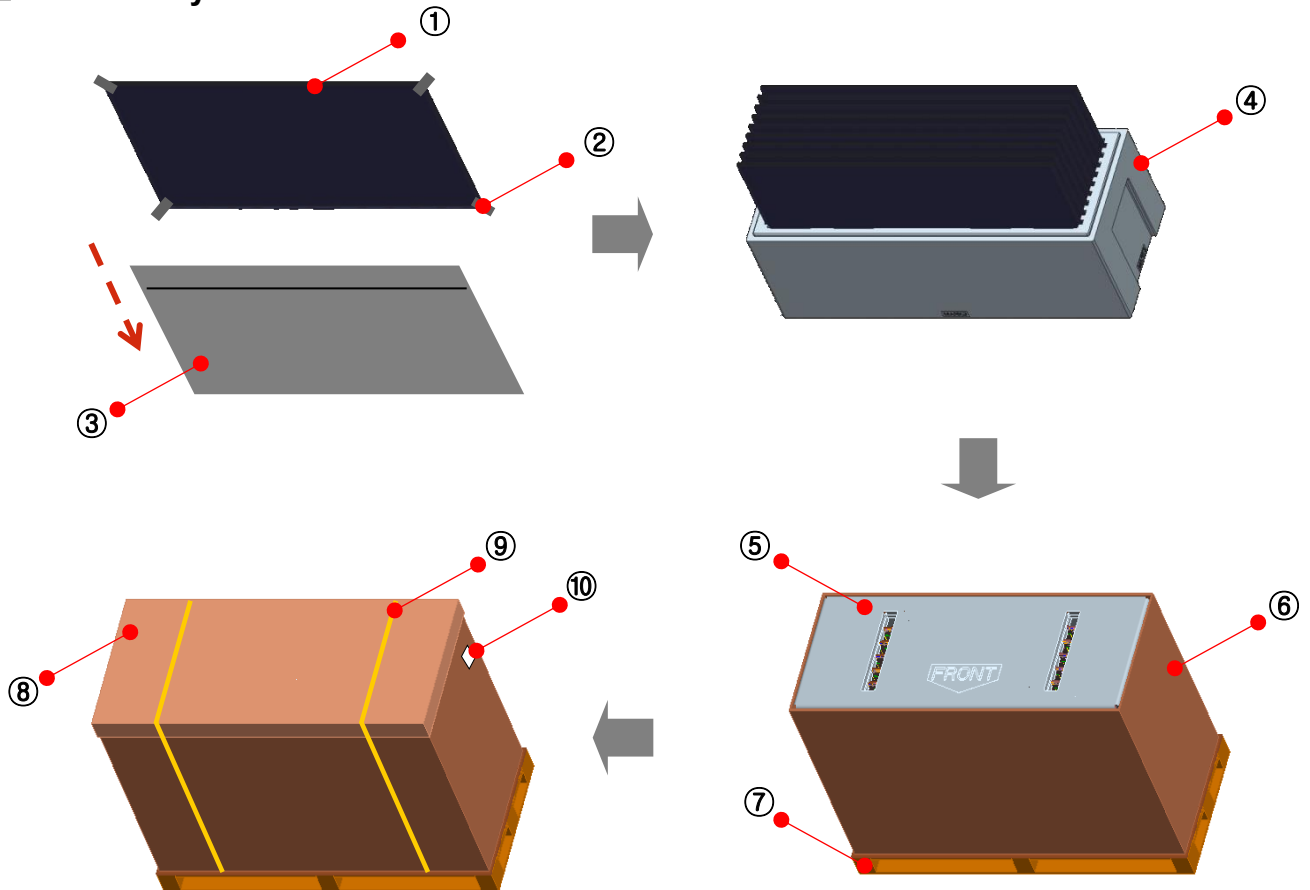

No.	Description	Material
1	LCM	-
2	Tape	Pulling Tape
3	Bag	Al
4	Bottom Packing	EPS
5	Top Packing	EPS
6	Angle Packing	Paper
7	Pallet	Plywood
8	Angle Cover	Paper
9	Band	PP
10	Label	Yupo Paper 100x70

Product Specification

# APPENDIX- II-1

■ LCM Label



■ Production site

- KTC (HZ, Huizhou) Co., LTD

Note

1.The origin of LCM Label will be changed according to the production site.



Product Specification

# APPENDIX- II-2

■ Pallet Label



## Product Specification

## # APPENDIX- III

## ■ Required signal assignment for Flat Link (Thine : THCV215) Transmitter

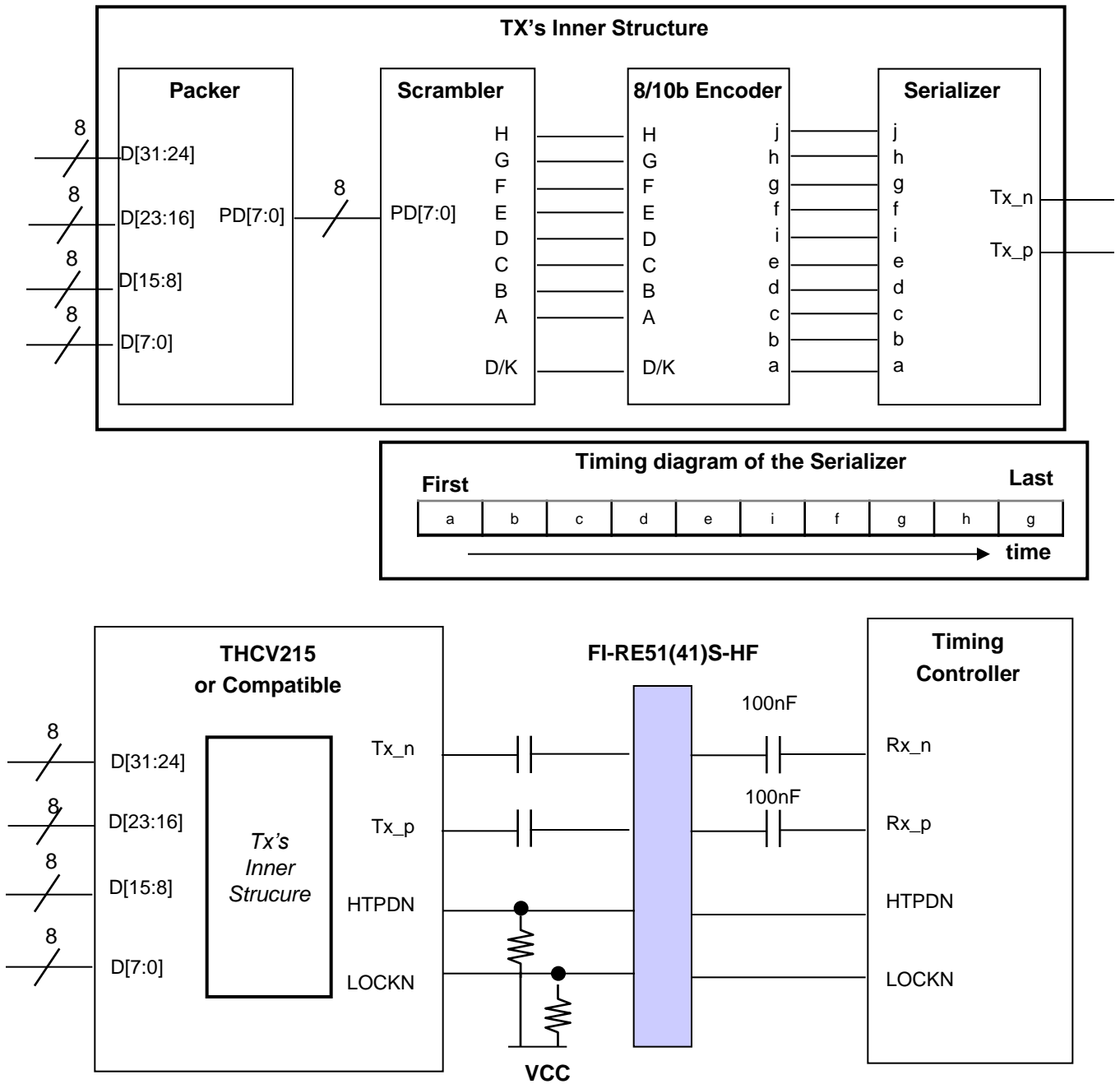

- notes: 1. The LCD module uses a 100 nF capacitor on positive and negative lines of each receiver input.  
 2. Refer to Vx1 Transmitter Data Sheet for detail descriptions. (THCV215 or Compatible)  
 3. About Module connector pin configuration, Please refer to the Page 8~9.

## # APPENDIX- IV-1

## ■ Option Pin Circuit Block Diagram

1) Circuit Block Diagram of Data format Selection pin

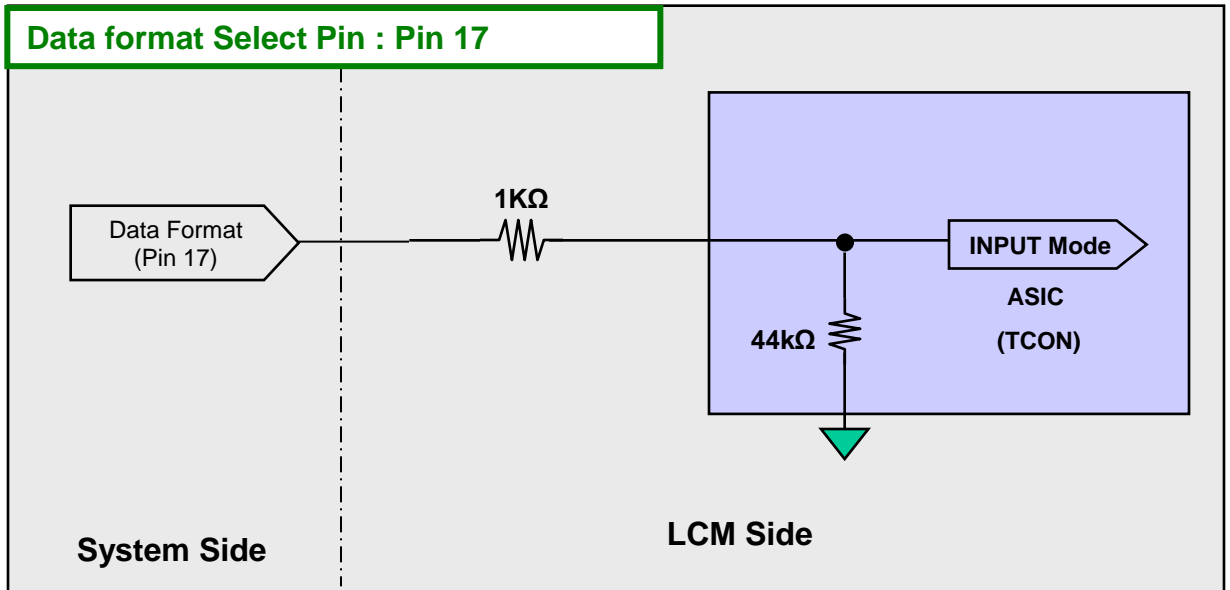

## # APPENDIX- IV-2

## ■ Option Pin Circuit Block Diagram

## 3) I2C(SDA/SCL) Selection pin

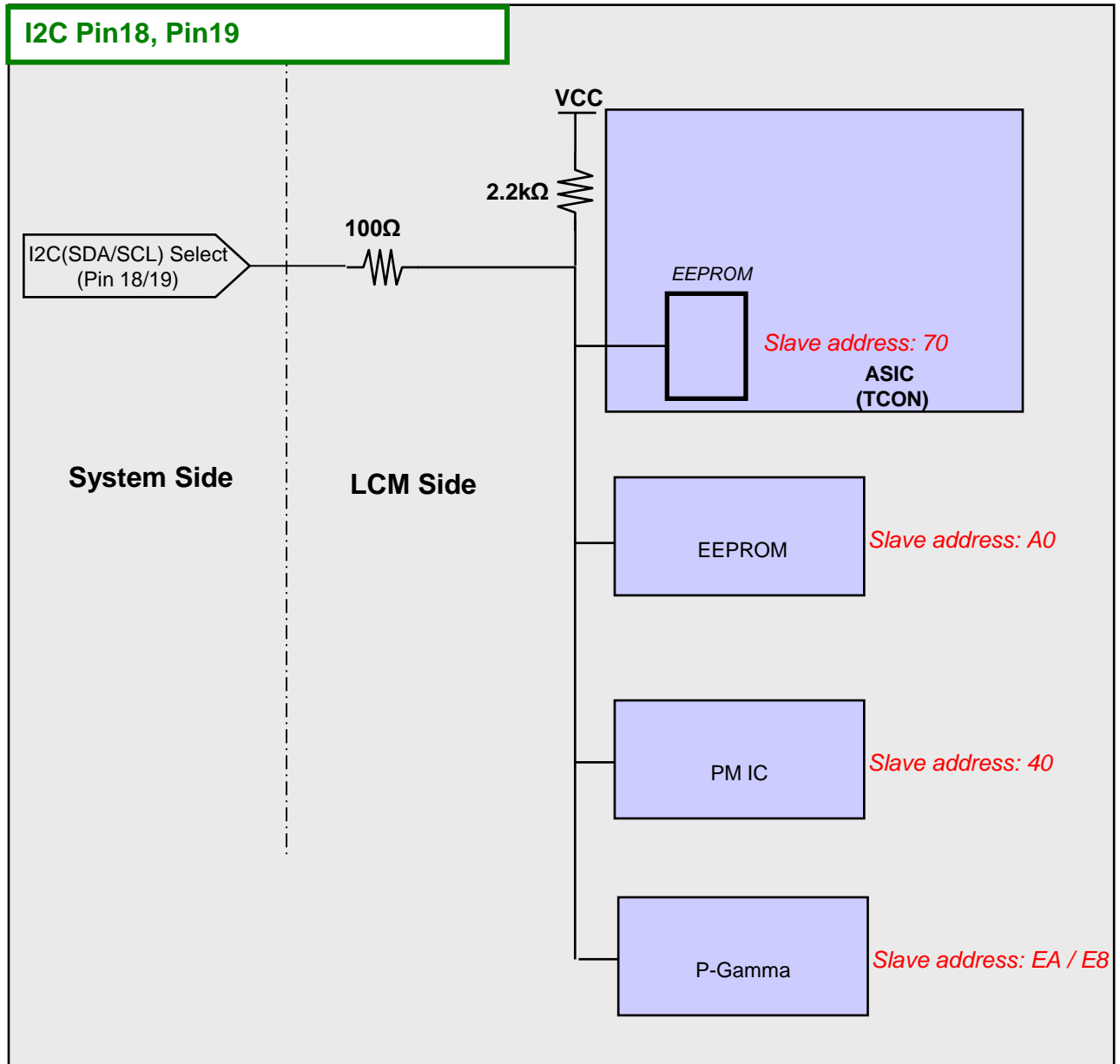

notes: 1. I2C Line of Set SoC avoid using slave address A0,E8,EA because LCD module uses those

## # APPENDIX- IV-3

## ■ Option Pin Circuit Block Diagram

## 4) Circuit Block Diagram of Bit Selection pin

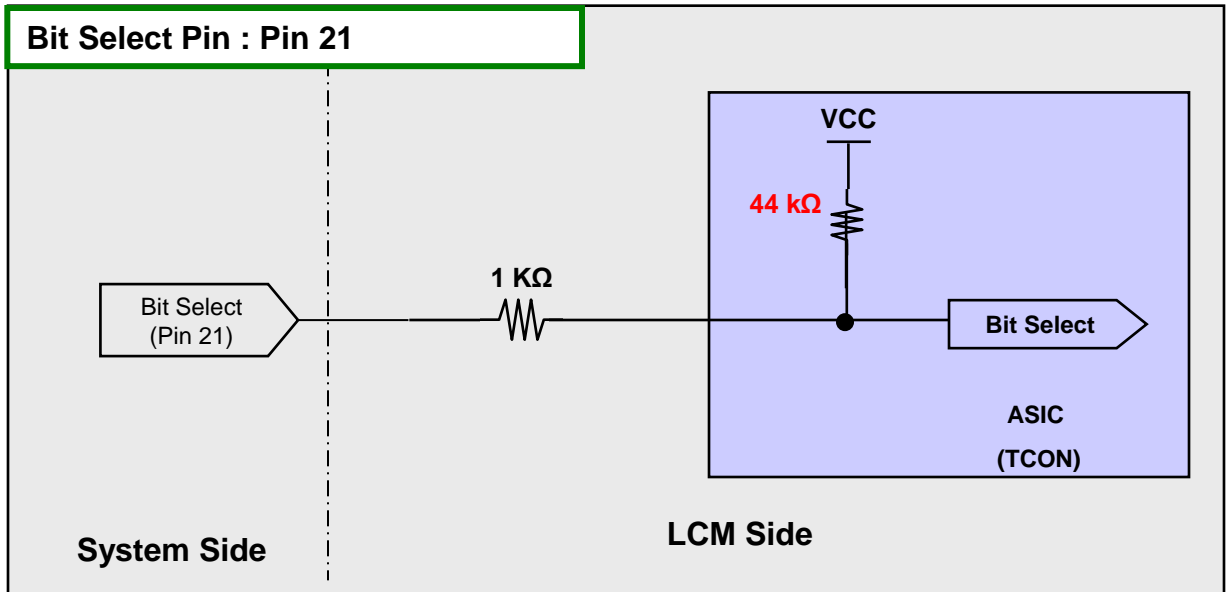

## 4) Circuit Block Diagram of L-Dim Enable Selection pin

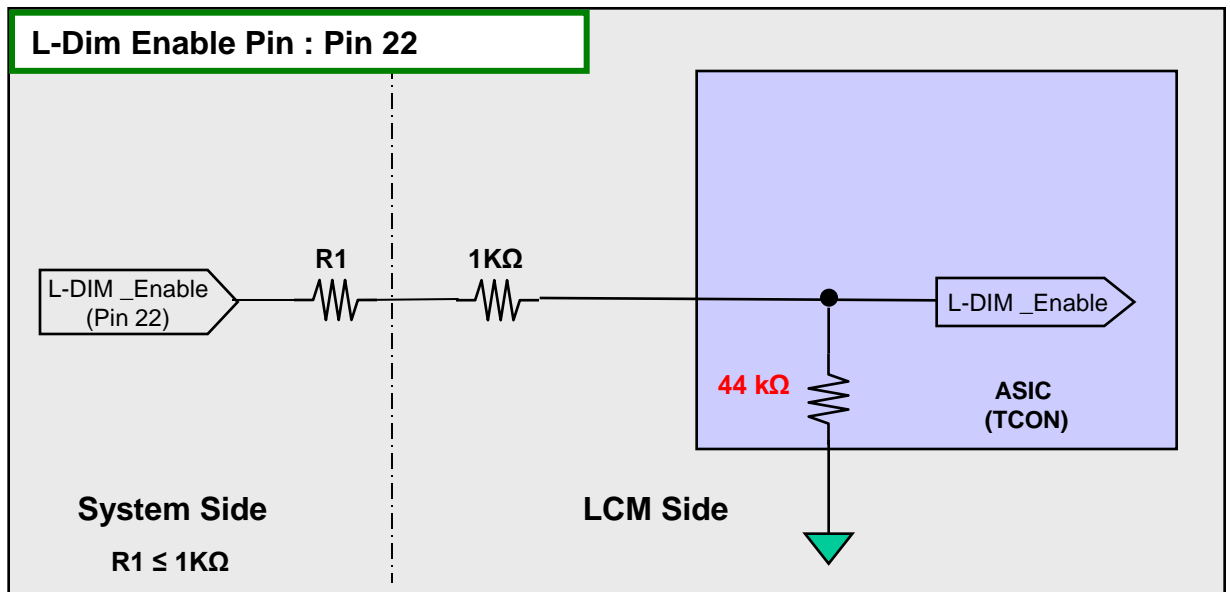

## # APPENDIX- IV-4

## ■ Option Pin Circuit Block Diagram

## 6) Circuit Block Diagram of AGP Selection pin

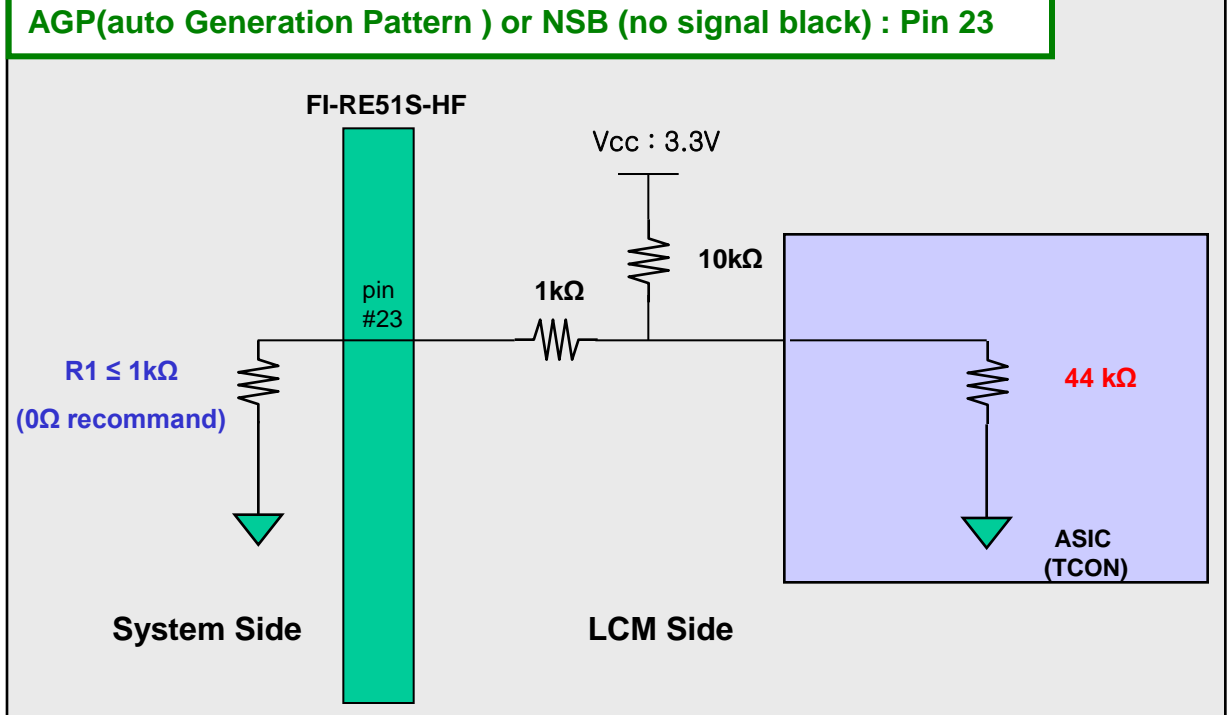

## 6) Circuit Block Diagram of HTPDN/ LOCKN Selection pin

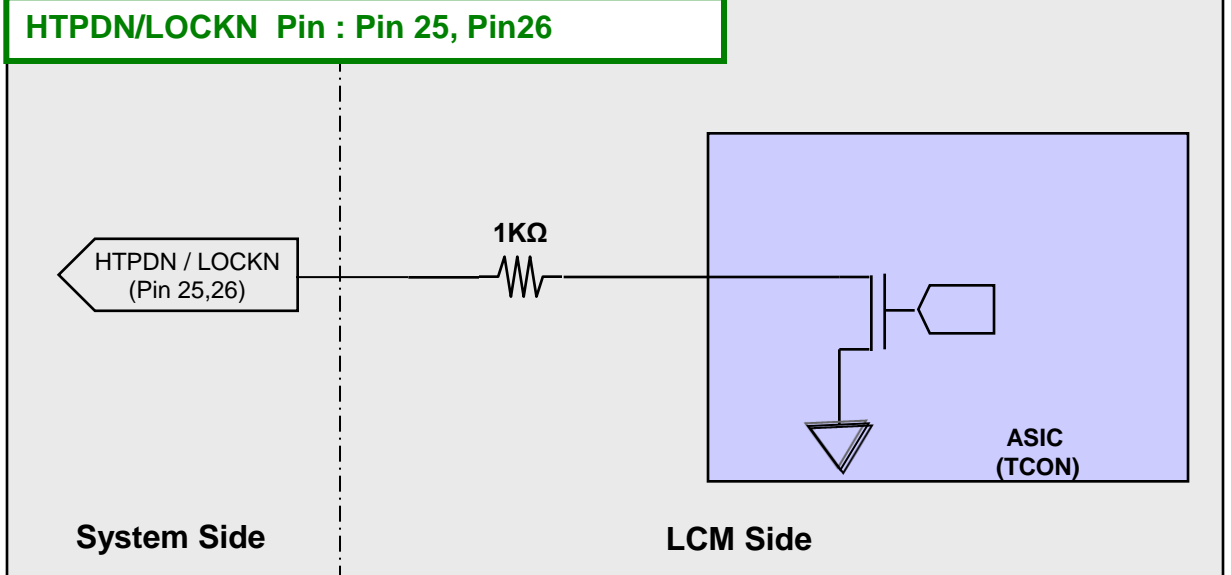

## Product Specification

## # APPENDIX- V-1

**Gray to Gray Response Time Uniformity**

This is only the reference data of G to G and uniformity for LD860EQN-PMG2 model.

## 1. G to G Response Time :

Response time is defined as Figure3 and shall be measured by switching the input signal for "Gray (N) " and "Gray(M)".(32Gray Step at 8bit)

## 2. G to G Uniformity

The variation of G to G Uniformity ,  $\delta_{G \text{ to } G}$  is defined as :

$$G \text{ to } G \text{ Uniformity} = \frac{\text{Maximum}(G \text{ to } G) - \text{Typical}(G \text{ to } G)}{\text{Typical}(G \text{ to } G)} \leq 1$$

\*Maximum (G to G) means maximum value of measured time (N, M = 0 (Black) ~ 1023(White), 128 gray step).

	0Gray	127ray	255Gray	...	895Gray	1023Gray
0Gray		TrR:0G→127G	TrR:0G→255G	...	TrR:0G→895G	TrR:0G→1023G
127Gray	TrD:127G→0G		TrR:127G→255G	...	TrR:127G→895G	TrR:127G→1023G
255Gray	TrD:255G→0G	TrD:255G→127G		...	TrR:255G→895G	TrR:255G→1023G
...	...	...	...	...	...	...
895Gray	TrD:895G→0G	TrD:895G→127G	TrD:895G→255G	...		TrR:895G→1023G
1023Gray	TrD:1023G→0G	TrD:1023G→127G	TrD:1023G→255G	...	TrD:1023G→895G	

## 3. Sampling Size : 2 pcs

4. Measurement Method : Follow the same rule as optical characteristics measurement.

## 5. Current Status

Below table is actual data of production on Feb. 19. 2019 ( LGD RV Event Sample)

	G to G Response Time [ms]		Uniformity
	Min.	Max.	
# 1	10.6	4.3	0.81
# 2	10.5	4.9	0.83

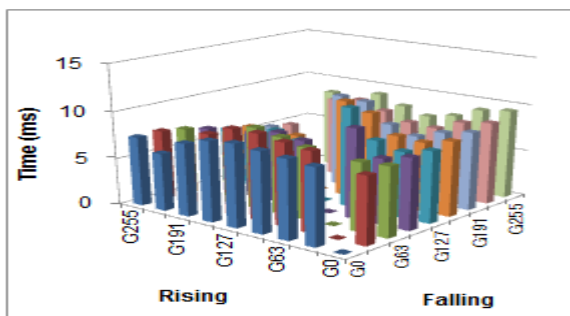

&lt; # 1 &gt;

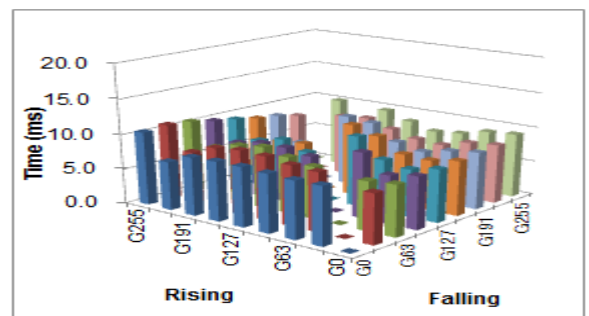

&lt; # 2 &gt;

## Product Specification

## # APPENDIX- VI

■ input mode of pixel data

Mode 1 : Non-Division				Mode 2 : 2 Division			
Lane	1 <sup>st</sup> Data	2 <sup>nd</sup> Data	Data#	Lane	1 <sup>st</sup> Data	2 <sup>nd</sup> Data	Data#
Lane0	1	9	3833	Lane0	1	5	1917
Lane1	2	10	3834	Lane1	2	6	1918
Lane2	3	11	3835	Lane2	3	7	1919
Lane3	4	12	3836	Lane3	4	8	1920
Lane4	5	13	3837	Lane4	1921	1925	3837
Lane5	6	14	3838	Lane5	1922	1926	3838
Lane6	7	15	3839	Lane6	1923	1927	3839
Lane7	8	16	3840	Lane7	1924	1928	3840



## # APPENDIX- VII-1

## ■ Vx1 Initialization Characteristics

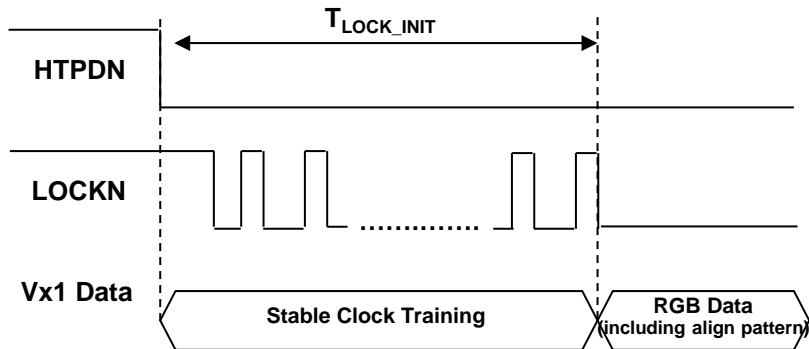

## 1). UHD60Hz T-Con

Characteristics	Symbol	Min	Typ	Max	Unit
Initial CDR lock time (From Stable CDR training to CDR lock)	$T_{LOCK\_INIT}$	0		<b>310</b>	ms

## # APPENDIX- VII-2

## ■ Vx1 Lock Timing In Normal Operation

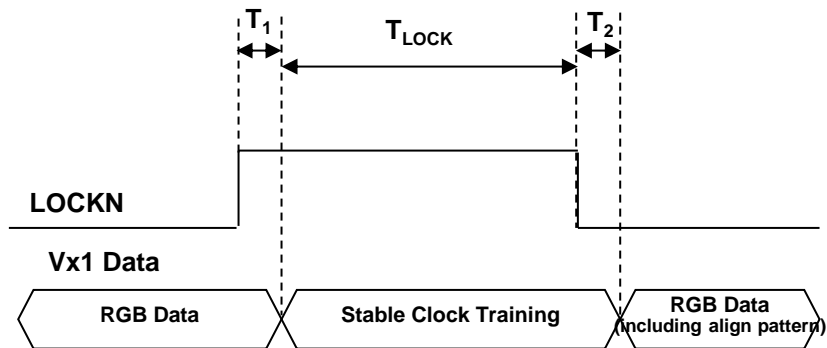

Characteristics	Symbol	Min	Typ	Max	Unit
CDR lock time from stable clock training pattern to LOCKN "Low" in normal operation	$T_{LOCK}$			2	ms
Latency from LOCKN "High" to clock training pattern	$T_1$			100	us
Latency from clock "Low" to normal RGB Data	$T_2$			100	us

※ Vx1 Rx should get clock training pattern in  $T_1$

※ Vx1 Rx should get RGB Data (including align pattern) in  $T_2$

## Product Specification

## # APPENDIX- VIII-1

## ■ Touch General Specification

The contents provide general characteristics for the model LD860EQN.

	Item		Spec	Notes
General Specification	System		Self Capacitive type	
	Multi Touch Points	Finger	20 Points	
		Active Pen	2 Points	
	Active touch area		Same as LCD A/A	
	Sensor	Type.	Advanced In-Cell Touch	
		Sensor Channel Pitch	6.58mm (X) x 6.91mm (Y)	
	Touch IC Information	IC	XC7Z007S	Xilinx FPGA
		Firmware	TBD	
		PID	8201	
		VID	1FD2	
	Number of Sensor Channel		288ea (X) x 156ea (Y)	
Interface		HID over USB		

## Product Specification

## # APPENDIX- VIII-2

## ■ Touch Performance Specification

## 1. Reporting Rate and Resolution

Property	Value
Input sampling and reporting rate	120Hz
Resolution <sup>1</sup>	0.5mm

<sup>1</sup> Minimum movement that gives consistent output coordinate change.

## 2. Accuracy

		Max	Unit
Finger	Center area	1.5	mm
	Edge area	2.0	mm
Active Pen	Center area	1.0	mm
	Edge area	1.5	mm

## 3. Input Separation

	Max	Unit
Input Separation, dege-to-edge <sup>1</sup>	15	mm

<sup>1</sup> Inner edges of objects(Diameter :  $\Phi$  7.0)

## 4. Jitter

		Max	Unit
Jitter	Moving	1.5	mm
	Stationary	0.5	mm

## Product Specification

## # APPENDIX- VIII-2

## ■ Touch Performance Specification

## 5. Latency

		Max	Unit
Input Latency	Touch down	35	ms
	Panning	25	ms

<sup>1</sup> Minimum movement that gives consistent output coordinate change.

## 6. Active Pen Information

<sup>1</sup>Products with the active pen package can provide the following input information. Details of the active pen available in separate specification.

	Value
Number of simultaneous unique pens	2ea
Tip size	2mm
Pressure resolution	4096
Number of unique Pen ID	2ea
Battery	AAA
Selectable buttons (assign function)	2
pen eraser	OK