

FEATURES

1. Package Type: 2"X 1"
2. Operating temperature range: -40°C - +85°C
3. High efficiency up to 90%
4. Isolation voltage: 1500VDC
5. The mechanism has input undervoltage protection,
6. output short circuit protection and over current protection
7. 2:1 Ultra-wide input voltage range
8. Fields of application: Power, industrial control, communications, Internet of Things, automotive, etc

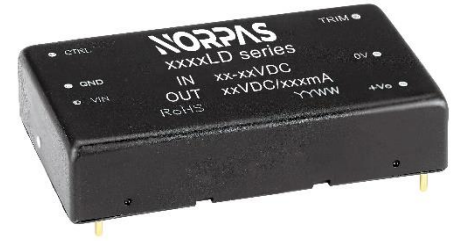

3 years
Warranty

Selection Guide

| Part No. | Input Voltage (VDC) | | Output | | Full Load Efficiency% (Typ.) | Capacitive Load(μF) Max. |
|-----------------|---------------------|---------|---------------|--------------|------------------------------|--------------------------|
| | Nominal (Range) | Maximum | Voltage (VDC) | Current (mA) | | |
| MFB2403LD-30WR3 | 24 (9-36) | 40 | 3.3 | 6000 | 85 | 10000 |
| MFB2405LD-30WR3 | | | 5 | 6000 | 88 | 10000 |
| MFB2412LD-30WR3 | | | 12 | 2500 | 88 | 2700 |
| MFB2415LD-30WR3 | | | 15 | 2000 | 90 | 1680 |
| MFB2424LD-30WR3 | | | 24 | 1250 | 90 | 680 |
| MFA2412LD-30WR3 | | | ±12 | ±1250 | 90 | #1250 |
| MFA2415LD-30WR3 | | | ±15 | ±1000 | 90 | #680 |
| MFB4803LD-30WR3 | 48 (18-75) | 80 | 3.3 | 6000/0 | 86 | 10000 |
| MFB4805LD-30WR3 | | | 5 | 6000/0 | 88 | 10000 |
| MFB4812LD-30WR3 | | | 12 | 2500/0 | 88 | 2700 |
| MFB4815LD-30WR3 | | | 15 | 2000/0 | 89 | 1680 |
| MFB4824LD-30WR3 | | | 24 | 1250/0 | 89 | 680 |

each output

Input Specifications

| Item | Operating Conditions | Min. | Typ. | Max. | Unit | |
|----------------------------------|----------------------------|---------------------------|------|---------|----------|----|
| Input Current(full load/no-load) | 24VDC nominal input series | 3.3VDC | -- | 976/60 | 993/100 | mA |
| | | 5VDC | -- | 1454/60 | 1488/100 | |
| | | Other | -- | 1388/6 | 1488/16 | |
| | 48VDC nominal input series | 3.3VDC | -- | 474/20 | 485/30 | |
| | | 5VDC | -- | 710/20 | 726/35 | |
| | | Other | -- | 702/5 | 744/10 | |
| Reflected Ripple Current | nominal input series | -- | 40 | -- | | |
| Impulse Voltage | 24VDC nominal input series | -0.7 | -- | 50 | VDC | |
| | 48VDC nominal input series | -0.7 | -- | 100 | | |
| Starting Voltage | 24VDC nominal input series | -- | -- | 18 | | |
| | 48VDC nominal input series | -- | -- | 36 | | |
| Ctrl | turn off module | connected GND or (0-1.2V) | | | | |
| | turn on module | No connected or (3.5-12V) | | | | |
| | Input current when off | -- | 5 | 8 | mA | |
| Input Filter | PI filter | | | | | |

Output Specifications

| Item | Operating Conditions | Min. | Typ. | Max. | Unit | |
|------------------------------|------------------------------------|---------------------------|-------|-------|-------|---|
| Output Voltage Accuracy | 5%-100% load | -- | ±1.0 | ±3.0 | % | |
| | 0%-5% load | -- | ±1.0 | ±5.0 | | |
| Linear Regulation | Vin=Min. to Max. @Full Load | -- | ±0.2 | ±0.5 | | |
| Load Regulation | 5%-100% load | -- | ±0.5 | ±1.0 | | |
| Ripple & Noise | 20MHz bandwidth,5%-100% load | -- | 50 | 100 | mVp-p | |
| Transient Recovery Time | 25% Load Step Change,nominal input | -- | 300 | 500 | µs | |
| Transient Response Deviation | 25% Load Step Change,nominal input | 3.3/5VDC | -- | ±5 | ±8 | % |
| | | Other | -- | ±3 | ±5 | |
| Temperature Coefficient | Full Load | -- | -- | ±0.03 | %/°C | |
| Trim | input voltage range | -- | ±10.0 | -- | % | |
| Over Voltage Protection | | 110 | -- | 190 | % | |
| Over Current Protection | | 110 | -- | 160 | % | |
| Short-Circuit Protection | | Continuous, Self-Recovery | | | | |

General Specifications

| Item | Operating Conditions | Min. | Typ. | Max. | Unit |
|-----------------------|---|------|------|------|---------|
| Isolation Voltage | Input-output, test time 1 minute, leakage current less than 1mA | 1500 | -- | -- | VDC |
| Insulation Resistance | Input-output, insulated voltage 500VDC | 1000 | -- | -- | MΩ |
| Isolation Capacitance | Input-output, 100KHz/0.1V | -- | 2000 | -- | pF |
| Operating Temperature | See Fig 1 | -40 | -- | +80 | °C |
| Storage Temperature | | -50 | -- | +125 | |
| Storage Humidity | Non-condensing | -- | -- | 95 | %RH |
| Soldering Profile | 1.5mm from case for 10 sec | -- | -- | 300 | °C |
| Switching Frequency | Full load, nominal input voltage | -- | 300 | -- | kHz |
| MTBF | MIL-HDBK-217F@25°C | 1000 | -- | -- | K Hours |

Mechanical Specifications

| | |
|---------------------------|-----------------------------|
| Case Material | Aluminum alloy |
| Package Dimensions | 25.4mm * 25.40mm * 11.80 mm |
| Weight | 28.00g(Typ.) |
| Cooling Method | Free air convection |

EMC Specifications

| | | | |
|------------|-------|---------------------------------------|------------------|
| EMI | CE | EN55032, FCC part 15 | CLASS B |
| | RE | | |
| EMS | ESD | EN61000-4-2 Air ± 8kV , Contact ± 6kV | perf. Criteria B |
| | RS | EN61000-4-3 10V/m | perf. Criteria A |
| | EFT | EN61000-4-4 ±2kV | perf. Criteria B |
| | Surge | EN61000-4-5 ±1kV | perf. Criteria B |
| | CS | EN61000-4-6 3Vrms | perf. Criteria A |

Typical Characteristic Curves

Temperature Derating (MFB2403/05LD-30WR3)

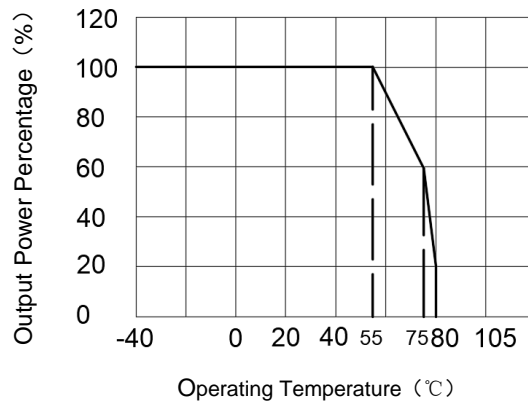
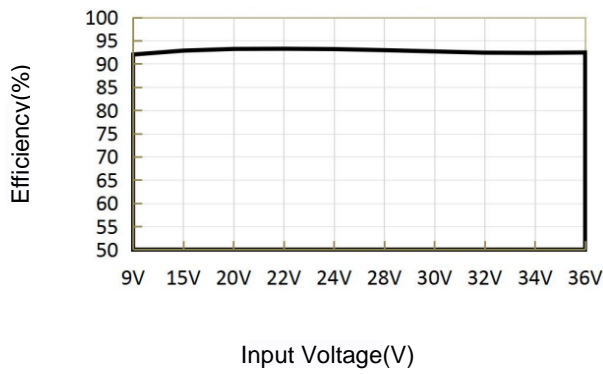
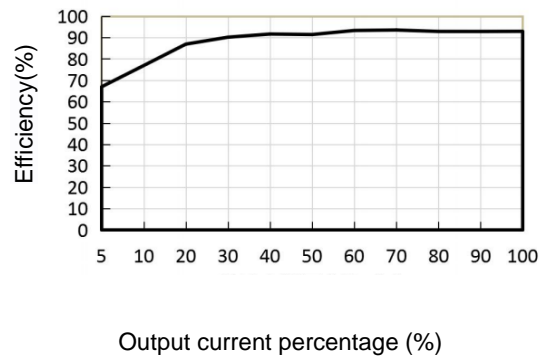

Fig 1

Efficiency VS input voltage (full load) (MFB2405LD-30WR3)



Efficiency VS out Power (MFB2405LD-30WR3)



Typical Circuit Design And Application

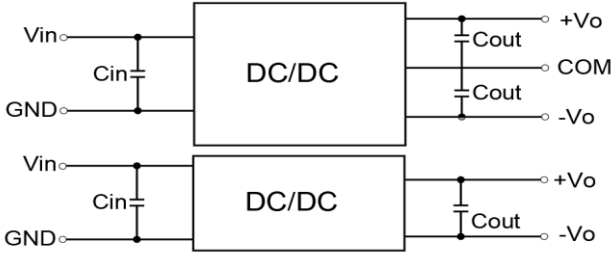

Fig 2

recommended component parameters

| Vout(VDC) | Cout (μF) | Cin(μF) |
|-----------|-----------|---------|
| 3.3/5 | 470 | 100 |
| 12/15/24 | 100 | |

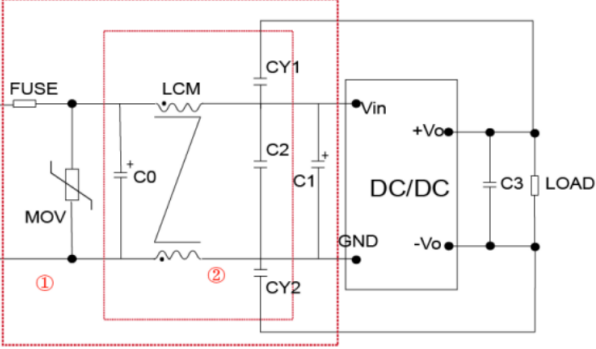
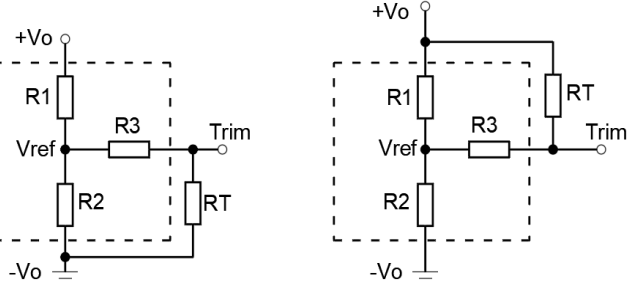

Fig 3

EMI recommended component parameters

| Model | Vin: 24VDC | Vin: 48VDC |
|-------|--|------------|
| FUSE | Select according to the actual input current of the customer | |
| MOV | 20D470K | 14D101K |
| C0 | 680μF/50V | 330μF/100V |
| C1 | 330μF/50V | 330μF/100V |
| C2 | 4.7μF/50V | 2.2μF/100V |
| C3 | Refer to the Cout parameter in Figure 2 | |
| LCM | 1mH | |



Trim up Trim down

Trim resistor connections (dashed line shows internal resistor network)

Trim

| Vout(V) | R1(Ω) | R2(KΩ) | R3(K) | Vref(V) |
|---------|-------|--------|-------|---------|
| 5 | 2.4 | 2.344 | 13.6 | 2.5 |
| 12 | 8.2 | 2.153 | 17.3 | 2.5 |
| 15 | 12 | 2.388 | 21.0 | 2.5 |
| 24 | 10 | 1.158 | 10.7 | 2.5 |

Up: $R_t = \frac{nR_2}{R_2 - n} - R_3$ $n = \frac{V_{ref}}{V_o - V_{ref}} * R_1$

Down: $R_t = \frac{nR_1}{R_1 - n} - R_3$ $n = \frac{V_o - V_{ref}}{V_{ref}} * R_2$

All DC-DC converters of this series are tested before delivery using the recommended circuit shown in Fig. 2. Input and/or output ripple can be further reduced by appropriately increasing the input & output capacitor values Cin and Cout and/or by selecting capacitors with a low ESR (equivalent series resistance). Also make sure that the capacitance is not exceeding the specified max. capacitive load value of the product.

Dimensions and Recommended Layout

Dimensions

PCB Printing Layout & Pin Definition Table

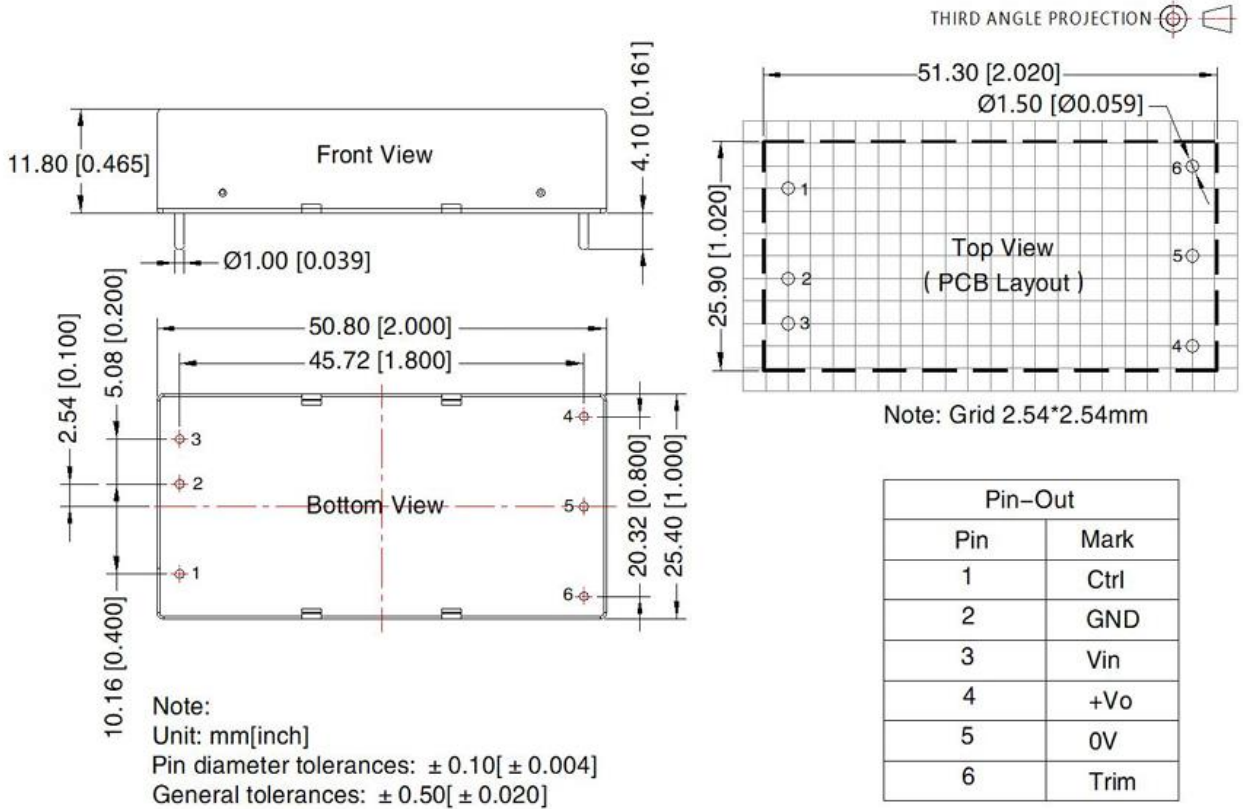

Note:

1. If the product works under the minimum required load, it cannot guarantee that the performance of the product complies with all the performance indicators in this manual;
2. The maximum capacitive load is tested under the input voltage range and full load condition;
3. Unless otherwise stated, all indexes in this manual are measured at Ta=25°C, humidity <75%RH, nominal input voltage and rated output load;
4. All index testing methods in this manual are based on the enterprise standards of the company;
5. Our company can provide product customization, specific needs can directly contact our technical staff;